

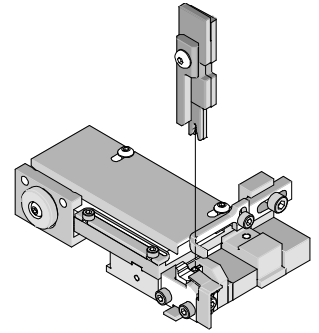

T2 Terminator Tooling Specification Sheet Order No. 63910-3800



FEATURES

- It is ideally suited for mid-volume bench operations
- This terminator can be installed in the TM42 and the TM40 press or Base Unit adapter for 3BF press
- Quick punch removal with the push of a button for fast and easy tooling change
- Track adjustment capabilities in the T2 Terminators for improved control of the bell mouth size and cutoff tab length
- T2 Terminator has standardized tooling with the Molex FineAdjust Applicator which will reduce your inventory requirements

SCOPE

Products: 2.00mm (.079") Pitch MicroBlade™ Wire-to-Wire Crimp Terminal 24-30 AWG.

Terminal Series No.	Terminal Order No.	Wire Size		Insulation Diameter		Strip Length	
		AWG	mm ²	mm	In.	mm	In.
50011	50011-8000	24-30	0.20-0.50	0.80-1.40	.031-.055	1.60-2.10	.063-.083
	39-00-0422						

DEFINITION OF TERMS

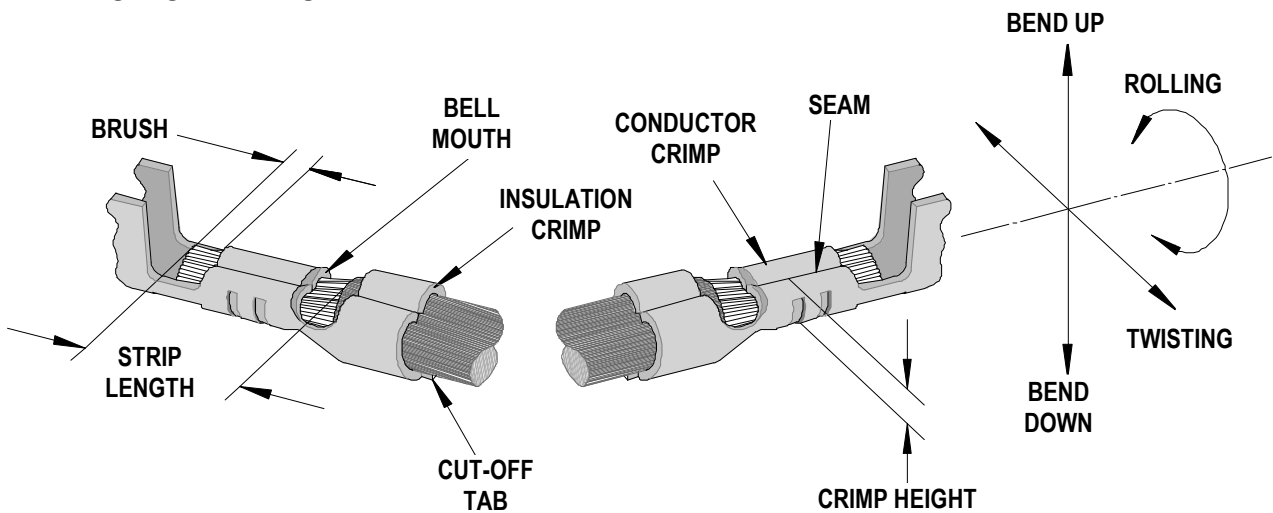

The above terminal drawing is a generic terminal representation. It is not an image of a terminal listed in the scope.

INSULATION CRIMP FORM

This crimp terminal is designed for miniaturization; therefore each dimension of insulation crimp portion appears small as compared to the terminal material thickness. In order to avoid insulation piercing the crimp forms by the insulation barrel, coining is provided inside of the insulation barrel. For this reason, various crimp forms will occur at the tip of the insulation crimp barrel shown in the figure below.

These crimp forms maybe changed completely by a small change in the wire, insulation punch or terminal.

These crimp forms are satisfactory for original function of the insulation crimp portion and it is confirmed that all of these forms below are acceptable insulation crimps.

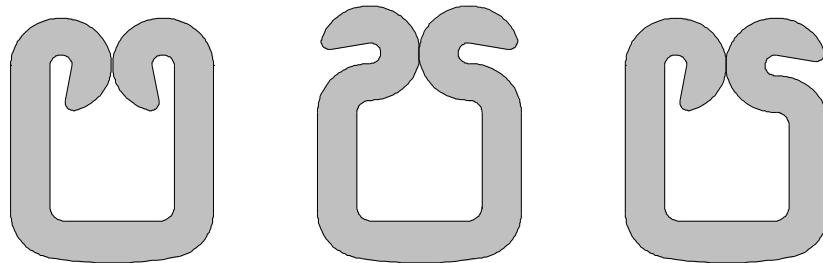

CRIMP SPECIFICATION

Terminal Series No.	Bell mouth		Cut-off Tab Maximum		Conductor Brush	
	mm	In.	mm	In.	mm	In.
50011	0.05-0.30	.002-.012	0.20	.008	0.00-0.70	.000-.028

Terminal Series No.	Bend up	Bend down	Twist	Roll	Punch Width mm (Ref)				Seam Seam shall not be open and no wire allowed out of the crimping area
	Degree				Degree		Conductor		
	mm	In.	mm	In.	mm	In.	mm	In.	
50011	5	4	3	3	1.00	.039	1.40	.055	

After crimping, the conductor profile should measure the following.

Terminal Series No.	Wire Size		Conductor Crimp Height		Pull Force Minimum	
	AWG	mm ²	mm	In.	N	Lb.
50011	24	0.20	0.60-0.65	.024-.026	29.36	6.60
	26	0.12	0.59-0.64	.023-.025	19.57	4.40
	28	0.08	0.56-0.61	.022-.024	9.78	2.20
	30	0.05	0.53-0.58	.021-.023	4.89	1.10

Pull Force should be measured with no influence from the insulation crimp.
The above specifications are guidelines to an optimum crimp.

PARTS LIST

T2 Terminator 63910-3800				
Item	Order No	Engineering No.	Description	Quantity
Perishable Tooling				
	63910-3870	63910-3870	Tool Kit (All "Y" Items)	REF
1	63444-1006	63444-1006	Conductor Punch	1 Y
2	63445-1013	63445-1013	Conductor Anvil	1 Y
3	634461410	63446-1410	Insulation Punch	1 Y
4	63445-1415	63445-1415	Insulation Anvil	1 Y
5	63443-0003	63443-0003	Cut-Off Plunger	1 Y
6	63443-0012	63443-0012	Front Plunger Retainer	1 Y
Other Components (REF 103750)				
7	11-18-4083	60707-8	Feed Guide	1
8	11-24-1067	4996-4	Cut-Off Plunger Spring	1
9	11-40-4039	8302-5	Plunger Striker	1
10	63443-0009	63443-0009	Front Scrap Chute	1
11	63443-0024	63443-0024	Key	1
12	63443-0085	63443-0085	Wire Stop L-Bracket	1
13	63443-0090	63443-0090	Wire Stop	1
14	63443-1703	63443-1703	17.30mm Height Spacer	1
15	63443-2217	63443-2217	17.00mm Coarse Spacer	1
16	63443-2306	63443-2306	3.30mm Fine Spacer	1
17	63443-6003	63443-6003	Rear Cover	1
Frame				
18	63800-8500	63800-8500	T2 Terminator	1
Hardware				
19	N/A	N/A	M3 by 6 Long SHCS	2**
20	N/A	N/A	M3 by 6 Long FHCS	1**
21	N/A	N/A	M4 by 6 Long SHCS	2**
22	N/A	N/A	M4 by 12 Long BHCS	2**
23	N/A	N/A	M4 by 14 Long SHCS	2**
24	N/A	N/A	M4 by 50 Long SHCS	2**
25	N/A	N/A	M5 by 12 Long SHCS	1**
26	N/A	N/A	#10-32 by 3/8" Long BHCS	1**
** Available from an industrial supply company such as MSC (1-800-645-7270).				

Assembly Drawing

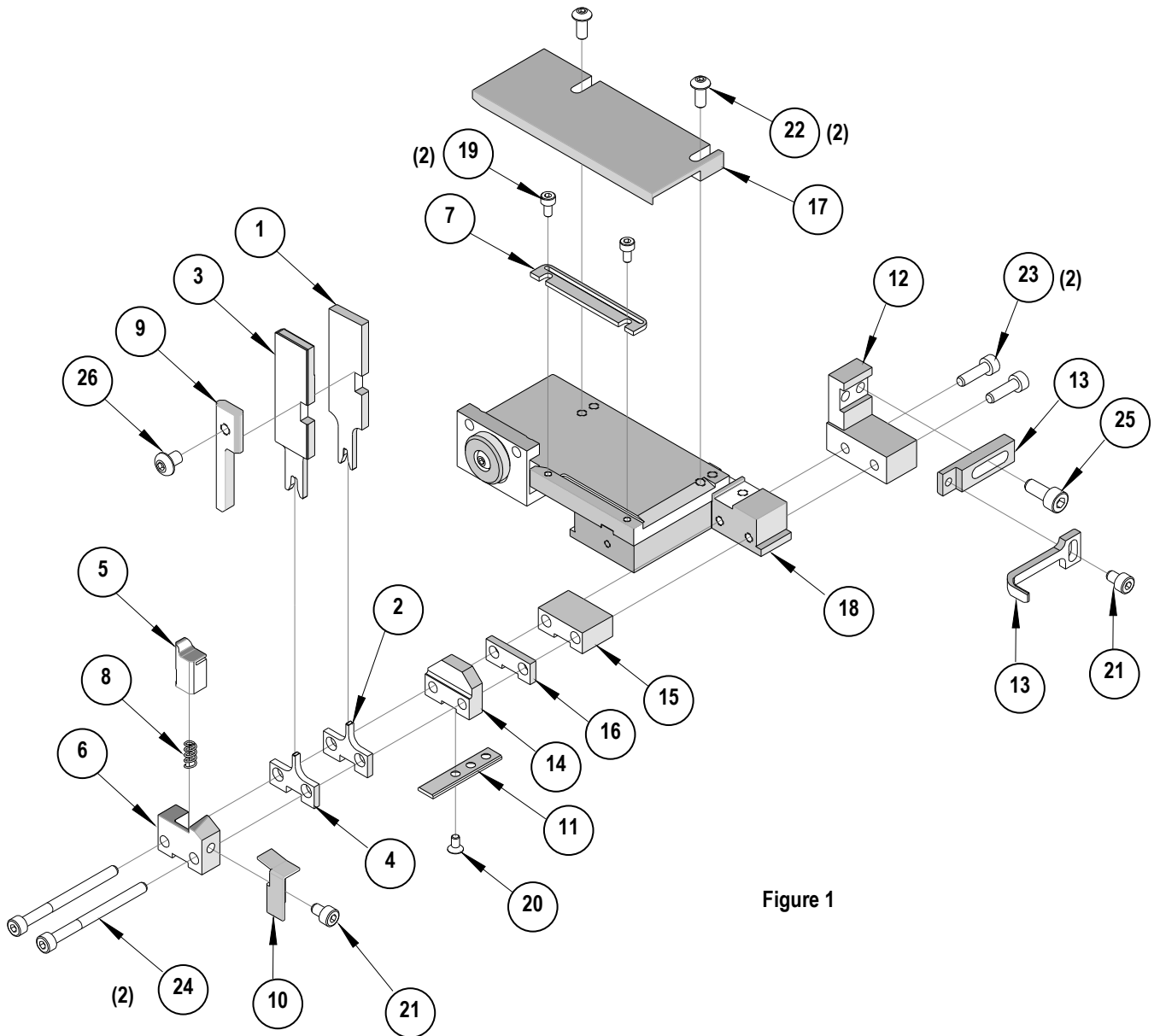

Figure 1

NOTES

Depending on the press vintage a feed finger assembly is supplied with the T2 Terminator.

1. To remove the existing feed finger assembly loosens the M4 x 10 mm set screw in the feed lever.
2. Select T2 Feed finger assembly from Terminator box.
3. Insert a screwdriver into the slot behind the feed lever and force the feed arm spring to the right.
4. Slide the T2 feed finger shaft for TM42 (11-40-5307) or (11-40-0123) for TM40 /Base Unit into the feed lever and to the left of the feed arm spring.
5. Release the feed arm spring.
6. Position feed finger for selected product. (Refer to Figure 5.1 in the T2 Manual).

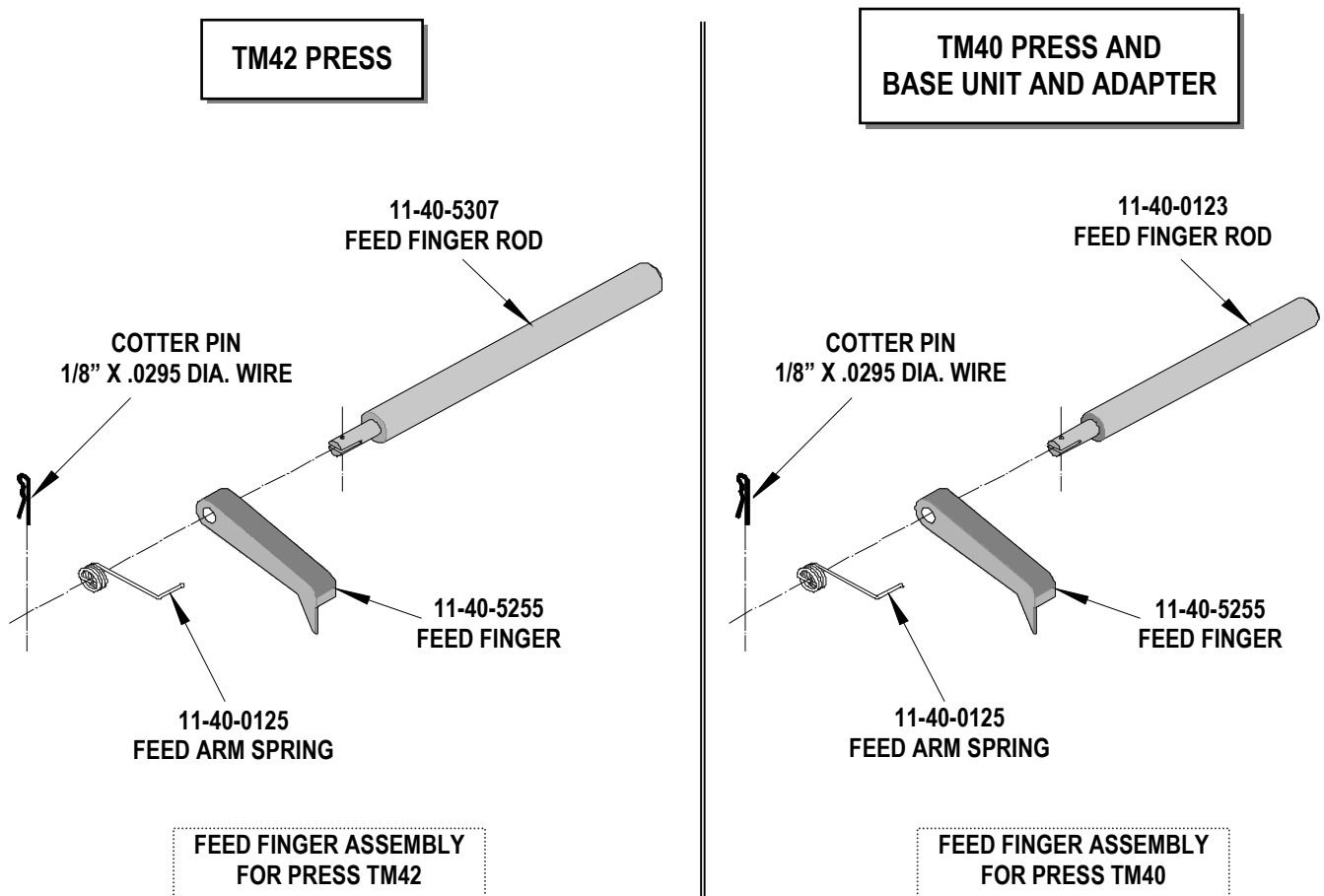

Figure 2

NOTES

1. Molex recommends an extra perishable tooling kit be maintained at your facility.
2. Verify tooling alignment by manually cycling the press before crimping under power. Check that all screws are tight.
3. Slugs, Terminals, Dirt and Oil should be kept clear of work area.
4. This Terminator should be only used in a Molex TM42, TM40, or 3BF Press with a Base Unit adaptor.
5. Wear safety glasses at all times.
6. For recommended maintenance refer to the TM40, TM42 Manual.

CAUTION: To prevent injury never operate this Terminator without the guards supplied with the press or in place. Reference the TM42 press manufacturer's instruction manual.

CAUTION: Molex crimp specifications are valid only when used with Molex terminals, applicators and tooling.

Americas Headquarters
Lisle, Illinois 60532 U.S.A.
1-800-78MOLEX
amerinfo@molex.com

Far East North Headquarters
Yamato, Kanagawa, Japan
81-462-65-2324
feninfo@molex.com

Far East South Headquarters
Jurong, Singapore
65-6-268-6868
fesinfo@molex.com

European Headquarters
Munich, Germany
49-89-413092-0
eurinfo@molex.com

Corporate Headquarters
2222 Wellington Ct.
Lisle, IL 60532 U.S.A.
630-969-4550
Fax: 630-969-1352

Visit our Web site at <http://www.molex.com>