

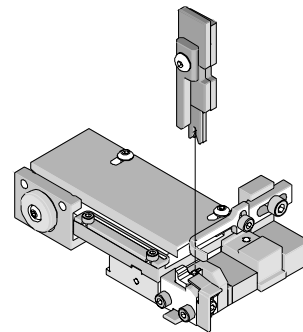

T2 Terminator Tooling Specification Sheet Part No. 63910-5200



FEATURES

- This terminator can be installed in the TM42 and the TM40 press or Base Unit adapter for 3BF press
- It is ideally suited for mid-volume bench operations
- Quick punch removal with the push of a button for fast and easy tooling change
- Track adjustment capabilities in the T2 Terminators for improved control of the bell mouth size and cutoff tab length
- T2 Terminator has standardized tooling with the Molex FineAdjust Applicator which will reduce your inventory requirements

SCOPE

Products: 2.00mm (.079") Pitch Wire-to-Board Crimp Terminal, 24-30 AWG

Terminal Order No.	Terminal Series No.		Wire Size		Insulation Diameter		Strip Length	
			AWG	mm ²	mm	In.	mm	In.
50212	50212-8000	39-00-0424	24-30	0.20-0.05	0.80-1.40	.031-.055	1.30-1.80	.051-.071
50394	50394-8051	50394-8099	24-30	0.20-0.05	0.80-1.40	.031-.055	1.30-1.80	.051-.071
	50394-8052	50394-8999						
	50394-8054							
59354	59354-8081	59354-8099	24-30	0.20-0.05	0.80-1.40	.031-.055	1.30-1.80	.051-.071

DEFINITION OF TERMS

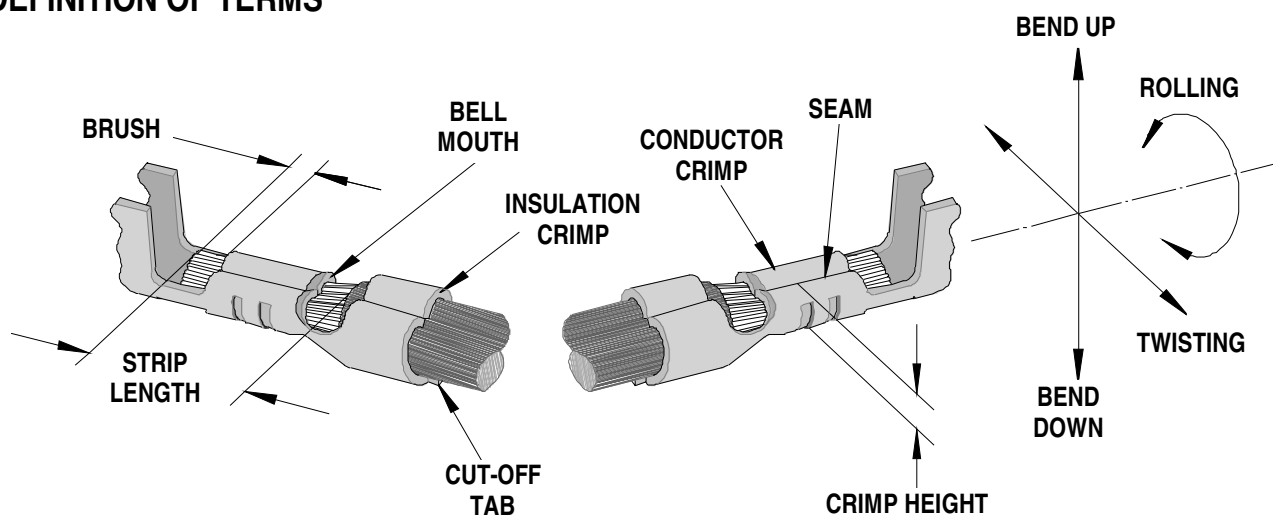

The above terminal drawing is a generic terminal representation. It is not an image of a terminal listed in the scope.

CRIMP SPECIFICATION

Terminal Series No.	Bell mouth		Cut-off Tab Max.		Conductor Brush	
	mm	In.	mm	In.	mm	In.
50212	0.05-0.35	.002-.014	0.20	.008	0.00-0.50	.000-.020
50394	0.05-0.35	.002-.014	0.20	.008	0.00-0.50	.000-.020
59354	0.05-0.35	.002-.014	0.20	.008	0.00-0.50	.000-.020

Terminal Series No.	Bend up	Bend down	Twist	Roll	Punch Width (Ref)				Seam
					Conductor		Insulation		
	Degree		Degree		mm	In	mm	In	
50212	4	3	3	4	1.00	.039	1.40	.055	Seam shall not be open and no wire allowed out of the crimping area
50394	4	3	3	4	1.00	.039	1.40	.055	
59354	4	3	3	4	1.00	.039	1.40	.055	

After crimping, the conductor profile should measure the following.

Terminal Series No.	Wire Size		Conductor Crimp Height		Pull Force Minimum	
	AWG	mm ²	mm	In.	N	Lb.
50212	24	0.20	0.60-0.65	.024-.026	29.3	6.60
	26	0.12	0.59-0.64	.023-.025	19.6	4.40
	28	0.08	0.56-0.61	.022-.024	9.8	2.20
	30	0.05	0.53-0.58	.021-.023	4.9	1.10
50394	24	0.20	0.60-0.65	.024-.026	29.3	6.60
	26	0.12	0.59-0.64	.023-.025	19.6	4.40
	28	0.08	0.56-0.61	.022-.024	9.8	2.20
	30	0.05	0.53-0.58	.021-.023	4.9	1.10
59354	24	0.20	0.60-0.65	.024-.026	29.3	6.60
	26	0.12	0.59-0.64	.023-.025	19.6	4.40
	28	0.08	0.56-0.61	.022-.024	9.8	2.20
	30	0.05	0.53-0.58	.021-.023	4.9	1.10

Pull Force should be measured with no influence from the insulation crimp.
The above specifications are guidelines to an optimum crimp.

PARTS LIST

T2 Terminator 63910-5200				
Item	Order No	Engineering No.	Description	Quantity
Perishable Tooling				
	63910-5270	63910-5270	Tool Kit (All "Y" Items)	REF
1	63444-1003	63444-1003	Conductor Punch	1 Y
2	63445-1013	63445-1013	Conductor Anvil	1 Y
3	63446-1430	63446-1430	Insulation Punch	1 Y
4	63445-1405	63445-1405	Insulation Anvil	1 Y
5	63443-0003	63443-0003	Front Cut-Off Plunger	1 Y
6	63443-0012	63443-0012	Front Plunger Retainer	1 Y
Other Components (REF 105250)				
7	11-18-4083	60707-8	Feed Guide	1
8	11-24-1067	4996-4	Cut-Off Plunger Spring	1
9	11-40-4039	8302-5	Plunger Striker	1
10	63443-0009	63443-0009	Front Scrap Chute	1
11	63443-0024	63443-0024	Key	1
12	63443-0085	63443-0085	Wire Stop L-Bracket	1
13	63443-0090	63443-0090	Wire Stop	1
14	63443-1703	63443-1703	17.30mm Height Spacer	1
15	63443-2217	63443-2217	17.00mm Coarse Spacer	1
16	63443-2308	63443-2308	3.40mm Fine Spacer	1
17	63443-6003	63443-6003	Rear Cover	1
Frame				
18	63800-8500	63800-8500	T2 Terminator	1
Hardware				
19	N/A	N/A	M3 by 6 Long SHCS	2**
20	N/A	N/A	M3 by 6 Long FHCS	1**
21	N/A	N/A	M4 by 6 Long SHCS	2**
22	N/A	N/A	M4 by 12 Long BHCS	2**
23	N/A	N/A	M4 by 14 Long SHCS	2**
24	N/A	N/A	M4 by 50 Long SHCS	2**
25	N/A	N/A	M5 by 12 Long SHCS	1**
26	N/A	N/A	#10-32 by 3/8" Long BHCS	1**
** Available from an industrial supply company such as MSC (1-800-645-7270).				

Assembly Drawing

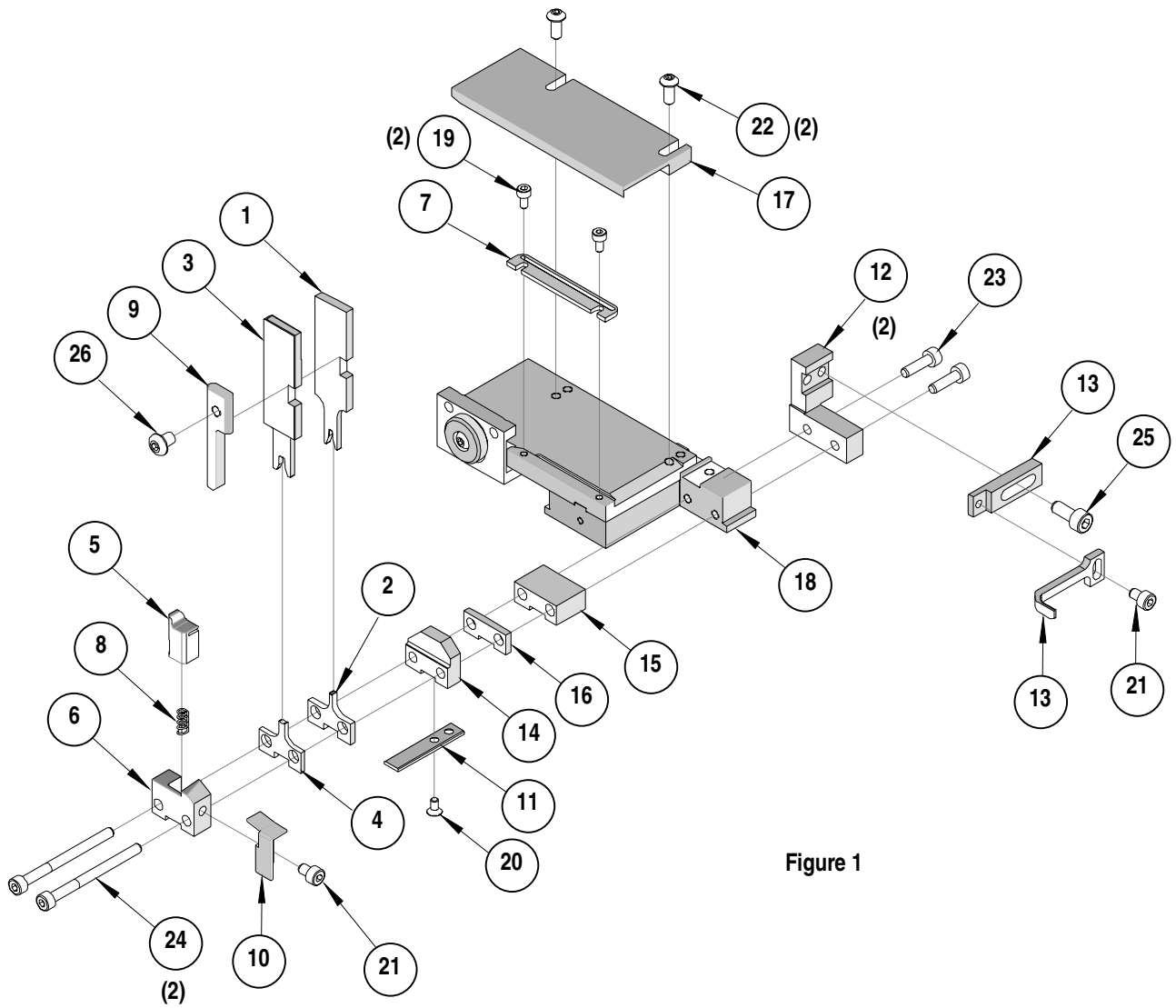

Figure 1

NOTES

Depending on the press vintage a feed finger assembly is supplied with the T2 Terminator.

1. To remove the existing feed finger assembly loosens the M4 x 10 mm set screw in the feed lever.
2. Select T2 Feed finger assembly from Terminator box.
3. Insert a screwdriver into the slot behind the feed lever and force the feed arm spring to the right.
4. Slide the T2 feed finger shaft for TM42 (11-40-5307) or (11-40-0123) for TM40 /Base Unit into the feed lever and to the left of the feed arm spring.
5. Release the feed arm spring.
6. Position feed finger for selected product. (Refer to Figure 5.1 in the T2 Manual).

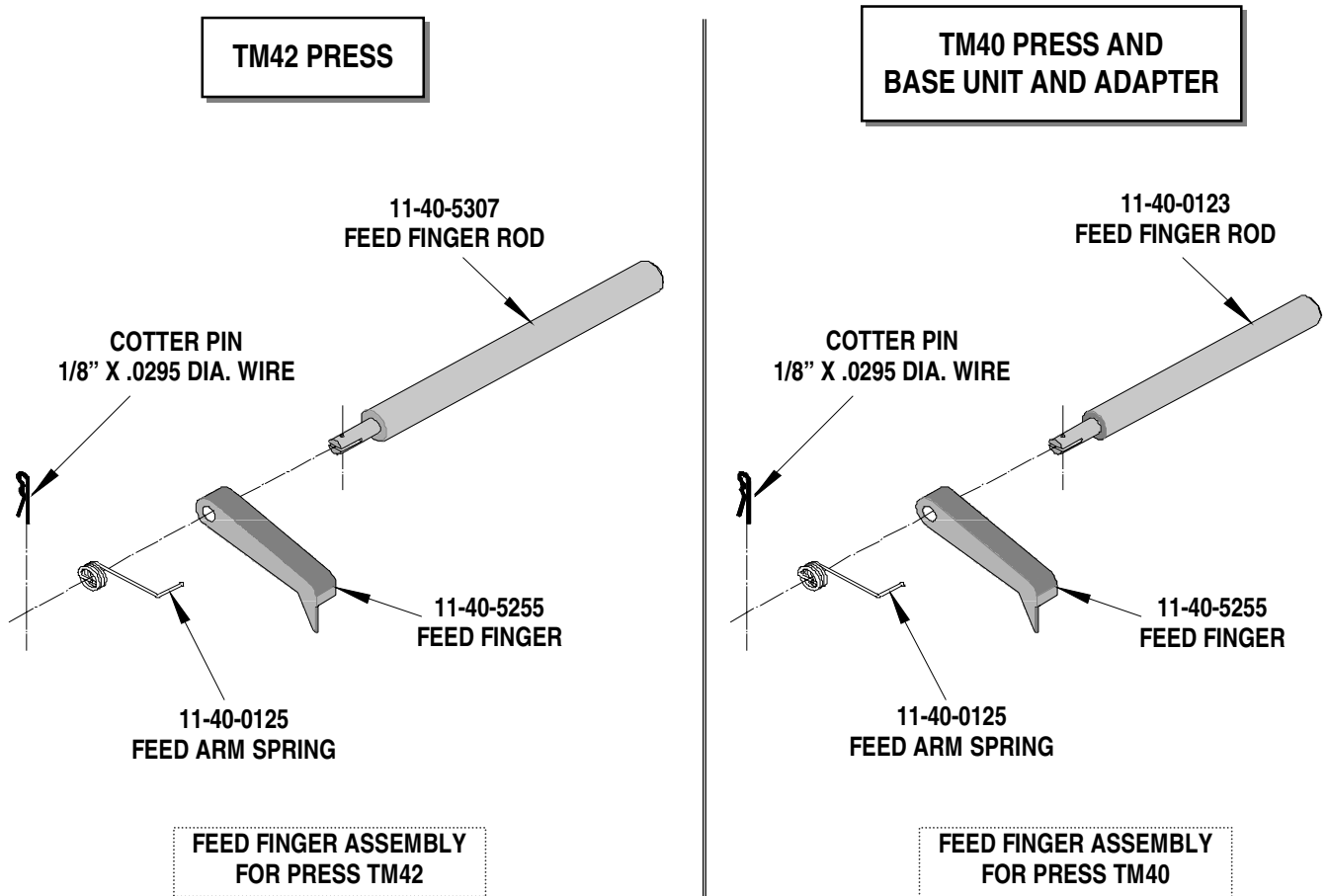

Figure 2

NOTES

1. Molex recommends an extra perishable tooling kit be maintained at your facility.
2. Verify tooling alignment by manually cycling the press before crimping under power. Check that all screws are tight.
3. Slugs, Terminals, Dirt and Oil should be kept clear of work area.
4. This Terminator should be only used in a Molex TM42, TM40, or 3BF Press with a Base Unit adaptor.
5. Wear safety glasses at all times.
6. For recommended maintenance refer to the TM40, TM42 Manual.

CAUTION: To prevent injury never operate this Terminator without the guards supplied with the press or in place. Reference the TM42 press manufacturer's instruction manual.

CAUTION: Molex crimp specifications are valid only when used with Molex terminals, terminators and tooling.

Americas Headquarters

Lisle, Illinois 60532 U.S.A.
1-800-78MOLEX
amerinfo@molex.com

Far East North Headquarters

Yamato, Kanagawa, Japan
81-462-65-2324
feninfo@molex.com

Far East South Headquarters

Jurong, Singapore
65-6-268-6868
fesinfo@molex.com

European Headquarters

Munich, Germany
49-89-413092-0
eurinfo@molex.com

Corporate Headquarters

2222 Wellington Ct.
Lisle, IL 60532 U.S.A.
630-969-4550
Fax: 630-969-1352

Visit our Web site at <http://www.molex.com>