

- NOTES:
- MATERIAL: COPPER ALLOY 151, 0.50mm THICK.
 - PLATING:
 - SELECT GOLD: 0.00076 MIN. SELECT. GOLD IN CONTACT AREA, 0.00254 MIN. SELECT *TIN IN CRIMP AREA, OVER 0.00127 NICKEL.
 - SELECT SILVER: 0.00254 MIN. SELECT. SILVER IN CONTACT AREA, 0.00254 MIN. SELECT *TIN IN CRIMP AREA, OVER 0.00127 NICKEL.
 - OVERALL TIN: 0.00254 MIN. BRIGHT *TIN OVER 0.00127 MIN. NICKEL
 - PRODUCT SPECIFICATION: PS-42815-001.
 - PACKAGING INFORMATION: PK-42815-001.
 - PART IS DESIGN IN METRIC.
 - TERMINALS FOR USE WITH STRANDED WIRE ONLY, STRANDED TINNED WIRE IS RECOMMENDED.
 - AFTER CRIMPING, THIS DIMENSION = 3.55mm MIN.
 - AFTER CRIMPING, THIS DIMENSION = 2.25mm MAX.
 - CRIMP SPECIFICATION: 638301000.
 - WHEN USING TIN-PLATED TERMINALS FOR APPLICATIONS INVOLVING VIBRATION AND/OR THERMAL CYCLING, MOLEX STRONGLY RECOMMENDS THE USE OF NYE LUBRICANT, NYOGEL 760G, ON THE MATING AREA OF THE TERMINAL. LUBRICANT SHOULD BE APPLIED AFTER THE TERMINALS ARE INSERTED INTO THE HOUSING.
 - PARTS CONFORM TO CLASS 'B' REQUIREMENT OF COSMETIC SPEC PS-45499-002.
 - REFER AS-42815-001 FOR TIN PLATED TERMINALS RECOMMENDED LUBRICATION PROCEDURE.

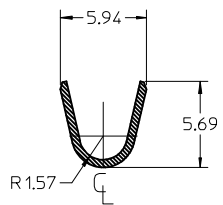

SECTION A-A
INSULATOR CRIMP

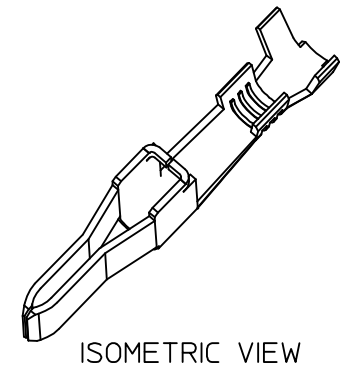
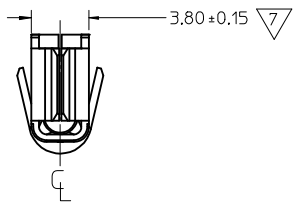
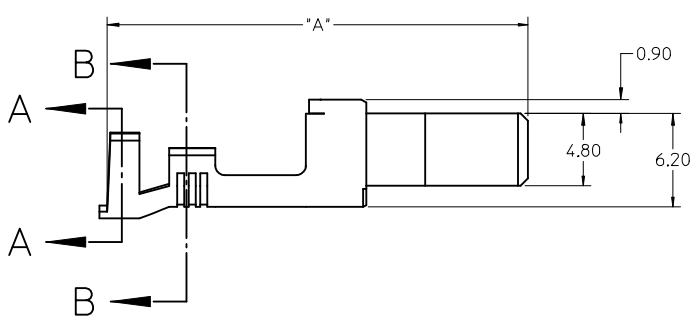
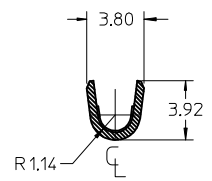

SECTION B-B
CONDUCTOR CRIMP

MATERIAL NO.	CONFIGURATION	DIM. "A"	PLATING	STATUS
42817-0041	STANDARD	27.60	TIN	PLANNED FOR OBSOLESCENCE
42817-0141	MAKE-FIRST/BREAK-LAST	29.60	TIN	PLANNED FOR OBSOLESCENCE
42817-0042	STANDARD	27.60	SELECT GOLD	ACTIVE
42817-0142	MAKE-FIRST/BREAK-LAST	29.60	SELECT GOLD	ACTIVE
42817-1044	STANDARD	27.60	SELECT SILVER	ACTIVE
42817-1144	MAKE-FIRST/BREAK-LAST	29.60	SELECT SILVER	ACTIVE

NEW SILVER PLATING PARTS ADDED DEC NO: UCP2015-2752 DRW: DRWINBR02 CHKD: APPR: KPRASAD 2013/12/24 2015/02/09	QUALITY SYMBOLS	GENERAL TOLERANCES (UNLESS SPECIFIED)	DIMENSION STYLE MM ONLY	SCALE 4:1	DESIGN UNITS METRIC	THIRD ANGLE PROJECTION
	▽=0	mm INCH	DRAWN BY DATE	TITLE		
	▽=0	4 PLACES ± --- ± ---	MFIRLEJ 2002/05/15	MINIFIT SR. MALE CRIMP TERMINAL, 14-16 AWG		
	▽=0	3 PLACES ± --- ± ---	CHECKED BY DATE	molex DOCUMENT NO. SD-42817-020 SHEET NO. 1 OF 1		
▽=0	2 PLACES ± 0.25 ± ---	JCOMERC I 2002/05/15				
	1 PLACE ± 0.40 ± ---	APPROVED BY DATE	THIS DRAWING CONTAINS INFORMATION THAT IS PROPRIETARY TO MOLEX INCORPORATED AND SHOULD NOT BE USED WITHOUT WRITTEN PERMISSION			
	0 PLACE ± ±	JCOMERC I 2002/05/15				
		ANGULAR ±1/2°	SEE CHART			
		DRAFT WHERE APPLICABLE MUST REMAIN WITHIN DIMENSIONS				