

CKT. SIZE	MATERIAL NUMBER	TOOLING	CKT. SIZE	DIM. "A"	DIM. "B"	DIM. "C"	DIM. "D"	DIM. "E"	DIM. "F"	DIM. "G"	DIM. "K"	DIM. "L"	DIM. "M"	DIM. "N"
18	44516-0009	TOOLED	18	55.30 (2.177)	39.00 (1.535)	33.60 (1.323)	3.59 (.141)	19.50 (.768)	47.40 (1.867)	37.00 (1.458)	49.94 (1.966)	40.77 (1.605)	18.72 (.737)	4.35 (.171)
20	44516-0010	NOT TOOLED	20	59.50 (2.343)	43.20 (1.701)	37.80 (1.488)	4.50 (.177)	21.60 (.850)	51.60 (2.032)	41.20 (1.623)	54.14 (2.131)	44.97 (1.770)	20.37 (.802)	5.26 (.207)
22	44516-0011	NOT TOOLED	22	63.70 (2.508)	47.40 (1.866)	42.00 (1.653)	3.59 (.141)	23.70 (.933)	55.80 (2.197)	45.40 (1.788)	58.34 (2.297)	49.18 (1.936)	22.92 (.902)	4.35 (.171)
24	44516-0012	TOOLED	24	67.90 (2.673)	51.60 (2.031)	46.20 (1.819)	4.50 (.177)	25.80 (1.016)	60.00 (2.362)	49.60 (1.953)	62.54 (2.462)	53.38 (2.102)	24.57 (.967)	5.26 (.207)

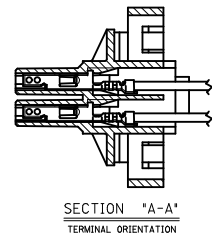

NOTES:

- MATERIAL: PBT, UNFILLED BLACK, V-0.
- FINISH: NOT APPLICABLE
- PRODUCT SPECIFICATION: PS-44516-001
- PACKAGING SPECIFICATION: PK-44516-002 FOR 18-22 CIRCUITS, PK-44516-003 FOR 24 CIRCUIT
- PART MATES WITH MINI-FIT B.M.I. PLUG #42475 AND HEADERS 42404, 42440, 44068, 43879, 43810, AND 43759.
- PART TO BE USED WITH MOLEX FEMALE TERMINAL #5556, 44476 OR 45750.
- A MAXIMUM TOLERANCE OF .127/(.050) ALLOWS FOR 2 POINTS OF ELECTRICAL CONTACT. A MAXIMUM TOLERANCE OF .51/(.020) ALLOWS FOR 4 POINTS OF CONTACT.
- CONNECTOR ASSEMBLIES ARE NOT TO BE MATED OR UNMATED WHILE CIRCUITS ARE LIVE.
- PANEL SHOULD BE PUNCHED IN THE DIRECTION OPPOSITE OF CONNECTOR INSERTION.
- THIS PART IS NOT INTENDED TO PROVIDE ANY ALIGNMENT OF CUSTOMER COMPONENTS OR MODULES, SUCH AS POWER SUPPLIES AND CHASSIS.
- PANEL CUT-OUT DIMENSIONS HAVE A TOLERANCE OF ±.076/(.003).
- IT IS THE RESPONSIBILITY OF THE CUSTOMER TO ENSURE THAT THE PANEL TO WHICH THE RECEPTACLE IS TO BE MOUNTED, IS SUFFICIENTLY SUPPORTED SO THAT FLEXING OF THE PANEL DURING MATING DOES NOT PREVENT THE CONNECTOR SYSTEM FROM BEING FULLY MATED.
- IT IS RECOMMENDED THAT THE CABLES EXITING THE RECEPTACLE BE DRESSED IN A MANNER THAT WILL ALLOW THE RECEPTACLE TO FLOAT FREELY WHEN MOUNTED IN IT'S RESPECTIVE PANEL.
- THIS PART IS NOT INTENDED TO ACT AS A HARD STOP FOR CUSTOMER COMPONENTS.
- WIRES TO BE DRESSED IN SUCH A MANNER TO ALLOW THE TERMINALS TO FLOAT FREELY IN THE POCKET
- PART CONFORMS TO CLASS 'B' REQUIREMENTS OF COSMETIC SPECIFICATION PS-45499-002
- THIS CONNECTOR ALLOWS FOR .127/(.050) MAX. MISALIGNMENT IN ANY DIRECTION.

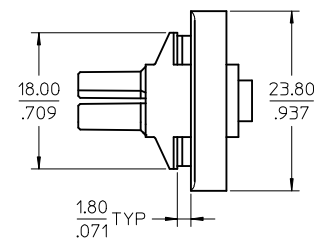
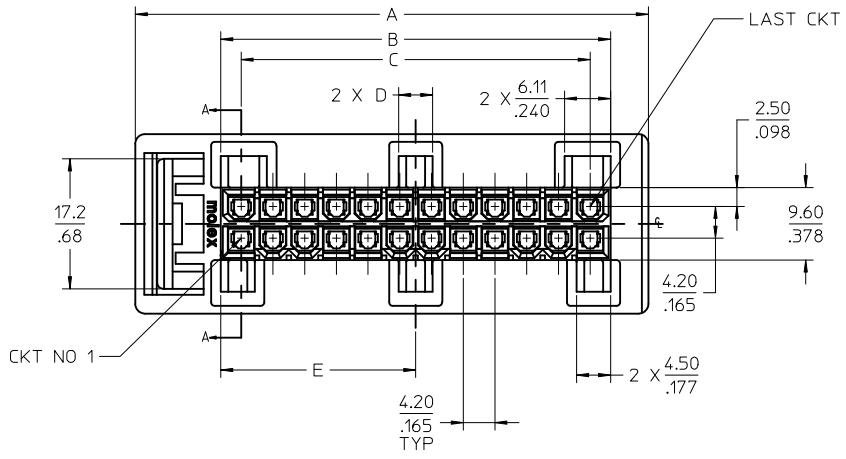
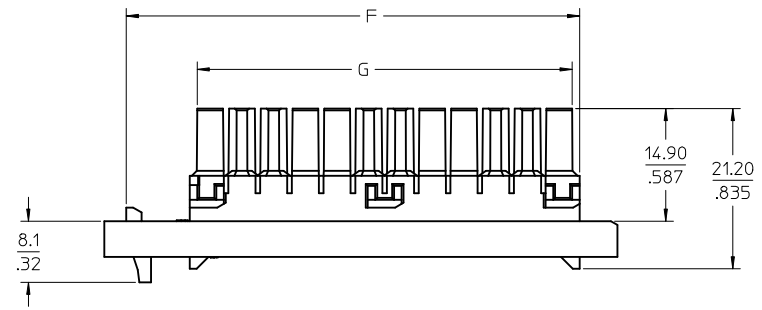

CORRECT ERRORS EC NO: UCP2012-2787 DRW: NGUYEN 2012/02/24 CHKD: J.BELL 2012/02/24 APPR: FSM:TH 2012/05/04	QUALITY SYMBOLS ∇=0 ∇=0 ∇=0	GENERAL TOLERANCES (UNLESS SPECIFIED)		DIMENSION STYLE MM/IN		SCALE 2:1	DESIGN UNITS METRIC	THIRD ANGLE PROJECTION																
		<table border="1"> <thead> <tr> <th></th> <th>mm</th> <th>INCH</th> </tr> </thead> <tbody> <tr> <td>4 PLACES</td> <td>± .01</td> <td>± .0005</td> </tr> <tr> <td>3 PLACES</td> <td>± .010</td> <td>± .0004</td> </tr> <tr> <td>2 PLACES</td> <td>± 0.25</td> <td>± .014</td> </tr> <tr> <td>1 PLACE</td> <td>± 0.35</td> <td>± .014</td> </tr> </tbody> </table>			mm	INCH	4 PLACES	± .01	± .0005	3 PLACES	± .010	± .0004	2 PLACES	± 0.25	± .014	1 PLACE	± 0.35	± .014	DRAWN BY HRIBAR		DATE 01/07/17	PANEL-MOUNT RECEPTACLE 18-24 CIRCUIT BLIND MATE MINI-FIT SLIDE 'N' LOCK		
			mm	INCH																				
		4 PLACES	± .01	± .0005																				
3 PLACES	± .010	± .0004																						
2 PLACES	± 0.25	± .014																						
1 PLACE	± 0.35	± .014																						
DRAFT WHERE APPLICABLE MUST REMAIN WITHIN DIMENSIONS		CHECKED BY BANDURA		DATE 01/07/17																				
MATERIAL NO. SEE CHART		APPROVED BY FSM:TH		DATE 2012/05/04		MOLEX INCORPORATED																		
SHEET NO. 1 OF 2		DOCUMENT NO. SD-44516-005		THIS DRAWING CONTAINS INFORMATION THAT IS PROPRIETARY TO MOLEX INCORPORATED AND SHOULD NOT BE USED WITHOUT WRITTEN PERMISSION																				

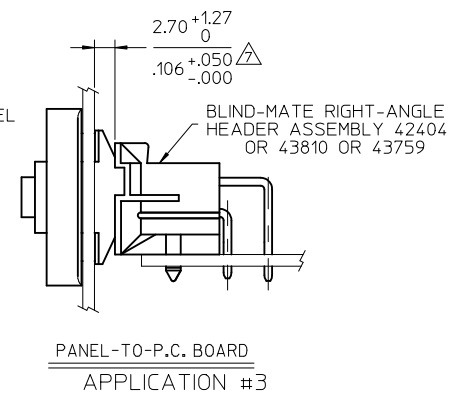
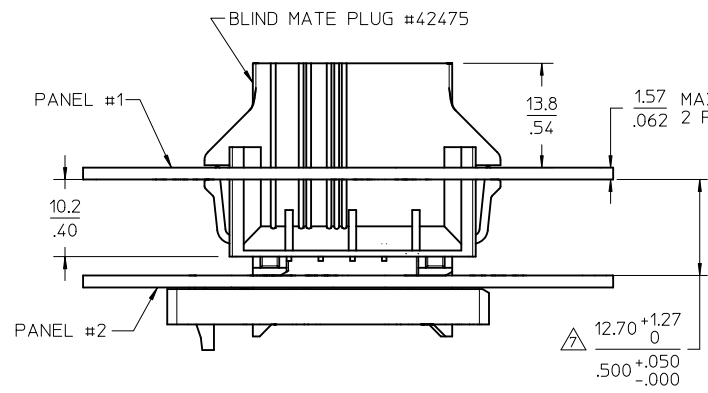
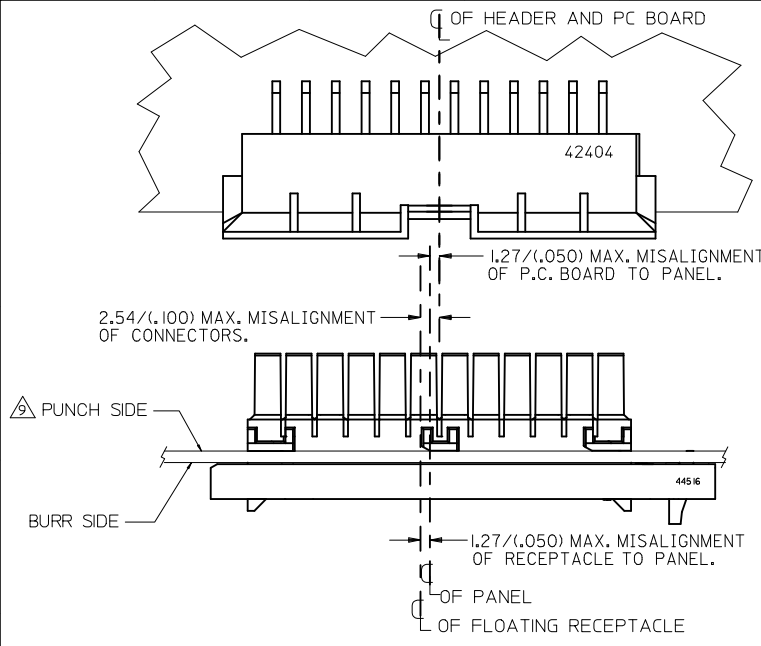

ALIGNMENT TOLERANCES FOR 1.27/(.050) MAX. BOARD-TO-PANEL MISALIGNMENT
(±1.27/(.050) RECEPTACLE FLOAT)

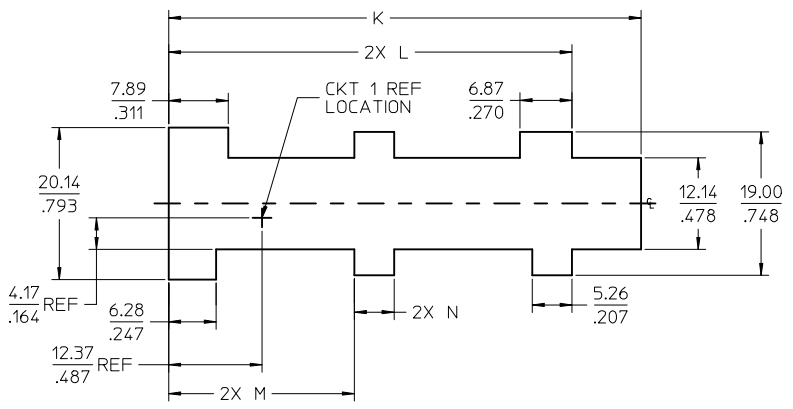

RECOMMENDED PANEL CUT-OUT FOR 1.57/1.19/(.062/.047) MAX./MIN. THICK PANEL
SHOWN FROM MATING SIDE
(SEE NOTE 9 & 11)

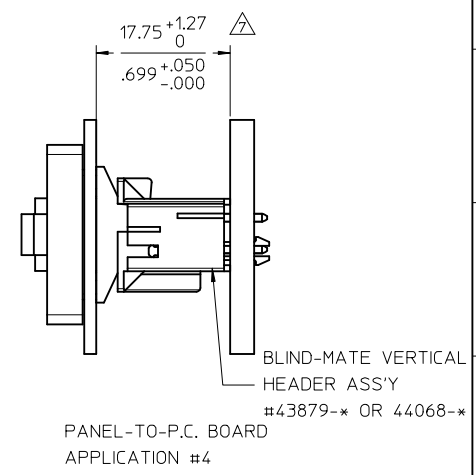
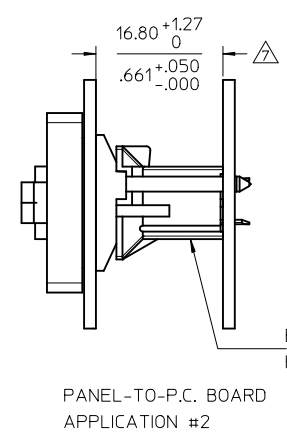

SEE SHEET 1 EC NO: UCP2012-2787 DRAWN: NGUYEN 2012/02/24 CHKD: BELL 2012/02/24 APPR: FSMITH 2012/05/04	QUALITY SYMBOLS ▽=0 ▽=0 ▽=0	GENERAL TOLERANCES (UNLESS SPECIFIED)		DIMENSION STYLE MM/IN		SCALE 2:1	DESIGN UNITS METRIC	THIRD ANGLE PROJECTION	
				mm	INCH	DRAWN BY HRIBAR		DATE 01/07/17	
		4 PLACES ± --- ± ---				CHECKED BY BANDURA		DATE 01/07/17	
		3 PLACES ± --- ± .010				APPROVED BY FSMITH		DATE 2012/05/04	
2 PLACES ± 0.25 ± .014				MATERIAL NO.		DOCUMENT NO.		SHEET NO.	
1 PLACE ± 0.35 ± ---		ANGULAR ± 1/2°		SEE SHEET 1		SD-44516-005		2 OF 2	
DRAFT WHERE APPLICABLE MUST REMAIN WITHIN DIMENSIONS				THIS DRAWING CONTAINS INFORMATION THAT IS PROPRIETARY TO MOLEX INCORPORATED AND SHOULD NOT BE USED WITHOUT WRITTEN PERMISSION					