

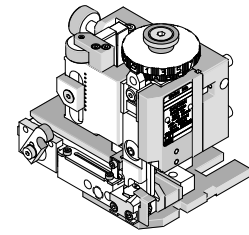

**Mini-Mac  
Applicator**

**Application Tooling  
Specification Sheet**



**Order No. 63895-2800**

**FEATURES**

- Directly adapts to most automatic wire processing machines
- Applicator designed to industry standard mounting and shut height 135.80mm (5.346")
- Quick set-up time; plus the crimp height, track and feed adjustments can be set without removing the applicator from the press
- Fine adjustment allows users to achieve target with little effort by adjusting in increments of .015mm (.0006") for conductor crimp height and .063mm (.0025") for insulation height
- Independent adjustment rings allow users to quickly adjust the conductor or insulation crimp height without affecting each other.

**SCOPE**

Products: PV Solar Pin and Socket Crimp Terminal, 10-12 AWG and 6.00-4.00mm<sup>2</sup>.

Terminal Series No.	Terminal Order No.	Wire Size		Insulation Diameter (Maximum)		Strip Length	
		AWG	mm <sup>2</sup>	mm	In.	mm	In.
130196	130196-0314	10-12	6.00-4.00	7.8	.31	7.00-10.00	.276-.394
130197	130197-0346	10-12	6.00-4.00	7.8	.31	7.00-10.00	.276-.394
93302	93302-0004	10-12	6.00-4.00	7.8	.31	7.00-10.00	.276-.394
93303	93303-0004	10-12	6.00-4.00	7.8	.31	7.00-10.00	.276-.394

**DEFINITION OF TERMS**

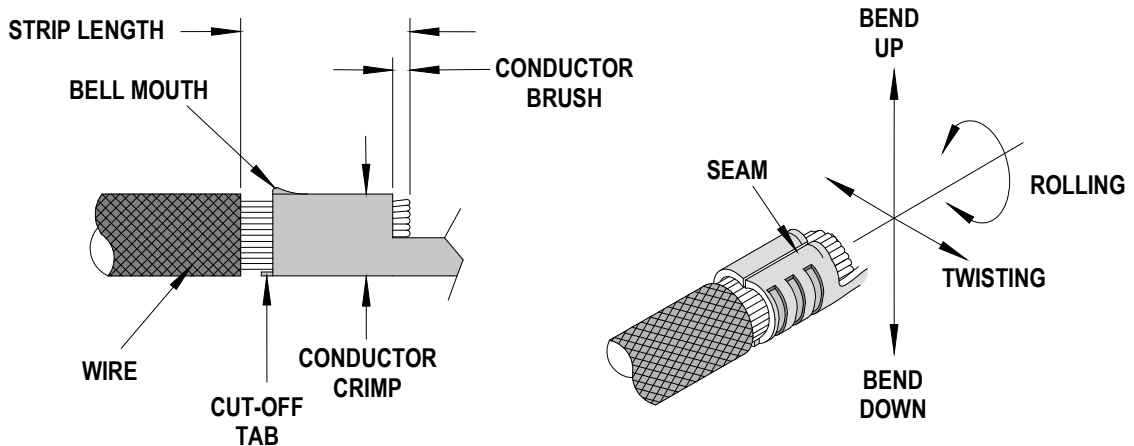

The above terminal drawing is a generic terminal representation. It is not an image of a terminal listed in the scope.

### CRIMP SPECIFICATIONS

Terminal Series No.	Wire Size		Bell mouth		Cut-off Tab Maximum		Conductor Brush	
	AWG	mm <sup>2</sup>	mm	In.	mm	In.	mm	In.
130196 and 93302	10	6.00	0.20-1.50	.008-.059	0.50	.020	1.00-3.00	.039-.118
	12	4.00	0.20-1.50	.008-.059	0.50	.020	1.00-3.00	.039-.118
130197 and 93303	10	6.00	0.20-1.50	.008-.059	0.50	.020	1.00-3.00	.039-.118
	12	4.00	0.20-1.50	.008-.059	0.50	.020	1.00-3.00	.039-.118

Terminal Series No.	Bend up	Bend down	Twist	Roll	Punch Width (Ref)		Seam
	Degree				Conductor		
					mm	In	
130196 and 93302	3	3	4	8	3.80	.150	Seam shall not be open and no wire allowed out of the crimping area
130197 and 93303	3	3	4	8	3.80	.150	

After crimping, the conductor profile should measure the following.

Terminal Series No.	Wire Size		Conductor Crimp Height		Pull Force Minimum	
	AWG	mm <sup>2</sup>	mm	In.	N	Lb.
130196 and 93302	10	6.00	2.15-2.25	.085-.089	356.0	80.0
	12	4.00	2.10-2.20	.083-.087	312.0	70.1
130197 and 93303	10	6.00	2.15-2.25	.085-.089	356.0	80.0
	12	4.00	2.10-2.20	.083-.087	312.0	70.1

**\* Tool Qualification Notes:**

1. Pull Force should be measured with no influence from the insulation crimp.
2. The above specifications are guidelines to an optimum crimp.

**PARTS LIST**

<b>Mini-Mac Applicator 63895-2800</b>				
<b>Item</b>	<b>Order No</b>	<b>Engineering No.</b>	<b>Description</b>	<b>Quantity</b>
<b>Perishable Tooling</b>				
	63895-2870	63895-2870	Tool Kit (All "Y" Items)	REF
1	63465-0078	63465-0078	Conductor Punch	1 Y
2	63456-0079	63456-0079	Conductor Anvil	1 Y
3	63443-0039	63443-0039	Front Cut-Off Plunger	1 Y
4	63443-0040	63443-0040	Cut-off Plunger Retainer	1 Y
<b>Other Components</b>				
5	11-18-4083	60707-8	Front Cover	1
6	63443-0009	63443-0009	Scrap Chute	1
7	63443-0024	63443-0024	Lower Tooling Key	1
8	63443-0041	63443-0041	Plunger Striker	1
9	63443-0092	63443-0092	Wire Stop	1
10	63443-1711	63443-1711	Height Spacer	1
11	63443-2206	63443-2206	Course Spacer (6.00mm)	1
12	63443-2209	63443-2209	Course Spacer (9.00mm)	1
13	63443-2312	63443-2312	Fine Spacer (3.60mm)	2
14	63443-6135	63443-6135	Rear Cover	1
15	63600-1290	63600-1290	Washer	1
16	63700-0539	63700-0539	Cut-off Plunger Spring	1
17	63700-2793	63700-2793	Hold Down Plunger Spring	1
18	63801-4481	63801-4481	Hold Down Block	1
19	63801-4482	63801-4482	Spring Retainer	1
20	63801-4483	63801-4483	Hold Down Plunger	1
21	63801-4484	63801-4484	Hold-Down Pad	1
22	63803-5146	63803-5146	Collar-6.40 Long	1
<b>Frame</b>				
23	63801-3201	63801-3201	Top	1
24	63801-3281	63801-3281	Base	1
25	63801-4650	63801-4650	Track	1
<b>Hardware</b>				
26	N/A	N/A	M3 by 5 Long SHCS	1**
27	N/A	N/A	M3 by 6 Long SHCS	2**
28	N/A	N/A	M3 by 6 Long FHCS	2**
29	N/A	N/A	M4 by 6 Long SHCS	2**
30	N/A	N/A	M4 by 12 Long BHCS	2**
31	N/A	N/A	M4 by 12 Long SHCS	2**
32	N/A	N/A	M4 by 50 Long SHCS	2**
33	N/A	N/A	M5 by 12 Long SHCS	1**
34	N/A	N/A	M8 by 30 Long BHCS	1**
35	N/A	N/A	2mm by 5 Long Dowel Pin	1**
** Available from an industrial supply company such as MSC (1-800-645-7270).				

### Assembly Drawing

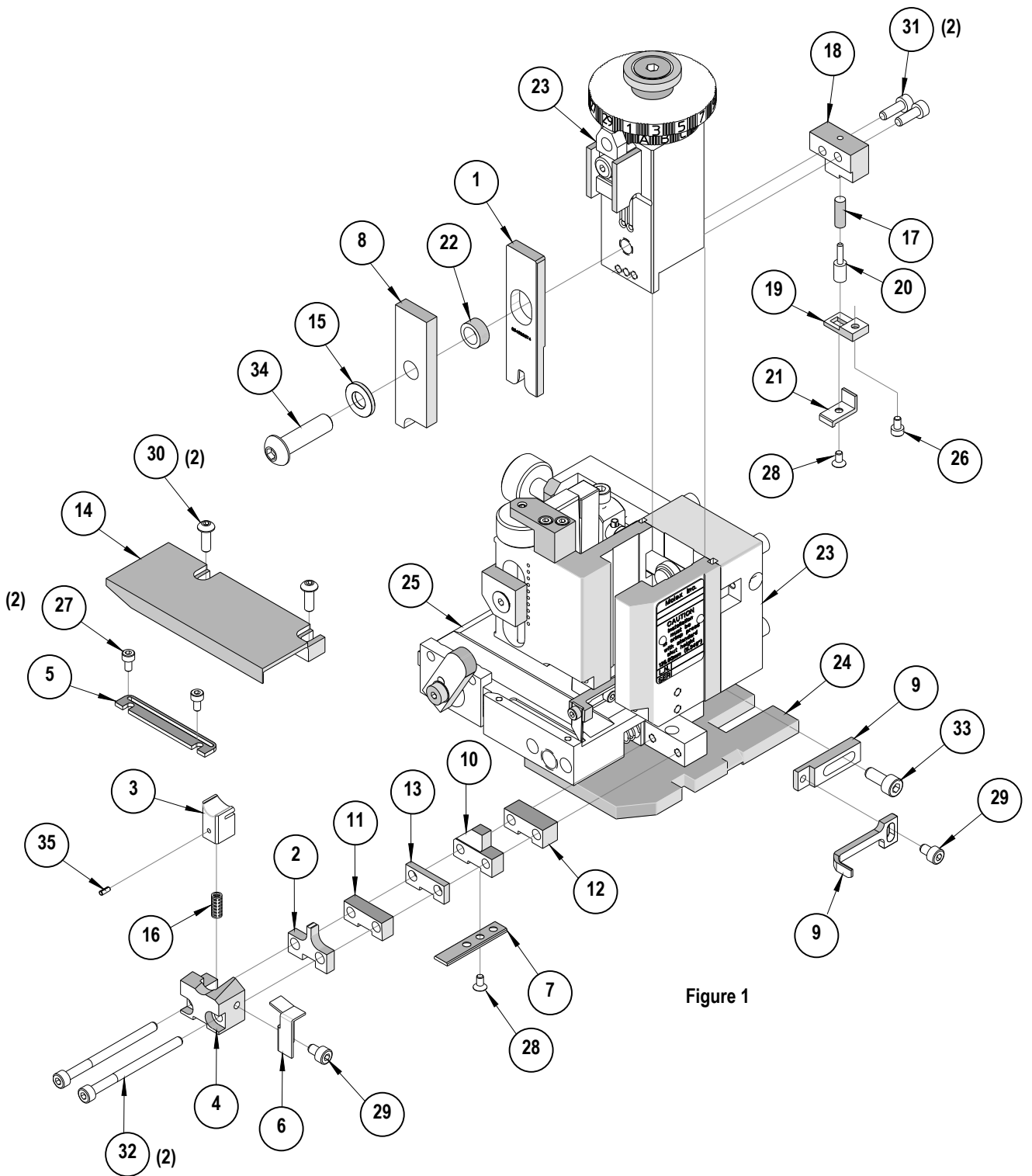

Figure 1

## NOTES

1. Molex recommends an extra perishable tooling kit be maintained at your facility.
2. Verify tooling alignment by manually cycling the press and applicator before crimping under power. Check that all screws are tight.
3. Slugs, terminals, dirt, and oil should be kept clear of work area.
4. Wear safety glasses at all times.
5. For recommended maintenance refer to the Mini-Mac Manual.

**CAUTION:** This applicator must only be used in a press with a shut height of 135.80 mm (5.346"). Tooling damage could result at a lower shut height.

**CAUTION:** To prevent injury, never operate this applicator without the guards supplied with the press or wire-processing machine in place. Reference the press or wire processing manufacturer's instruction manual.

**CAUTION:** Molex crimp specifications are valid only when used with Molex terminals, applicators and tooling.

## Contact Information

For more information on Molex application tooling please contact Molex at 1-800-786-6539.

<http://www.molex.com>