

<b>Mini-Mac Applicator</b>		
	<b>Application Tooling Specification Sheet</b>	

**FEATURES**

- Directly adapts to most automatic wire processing machines
- Applicator designed to industry standard mounting and shut height 135.80mm (5.346")
- Quick set-up time; plus the crimp height, track and feed adjustments can be set without removing the applicator from the press
- Fine adjustment allows users to achieve target with little effort by adjusting in increments of .015mm (.0006") for conductor crimp height and .063mm (.0025") for insulation height
- Independent adjustment rings allow users to quickly adjust the conductor or insulation crimp height without affecting each other.

**SCOPE**

Products: Sabre™ Male Flat Blade Crimp Terminal, 14 and 16 AWG UL1015.

Terminal Series No.	Terminal Order No.		Wire Size		Insulation Diameter				Strip Length	
					IPC/WHMA-A620 ♦		Terminal ♦♦			
					AWG	mm <sup>2</sup>	mm	In.		
43178	43178-2001	43178-6001	14-16	2.00-1.30	3.60-3.10	.142-.122	3.60-3.10	.142-.122	3.96-5.54	.156-.218
	43178-2002	43178-6002								

♦ To achieve optimum IPC-A620 insulation crimps, use this insulation OD range.  
 ♦♦ Overall insulation OD specification for terminal.  
 For (2) 18 AWG or (2) 20 AWG UL1015 crimping applications, use 63901-3100 Applicator.  
 For 14-16 AWG UL1007 crimping applications, use 63901-3200 Applicator.

**DEFINITION OF TERMS**

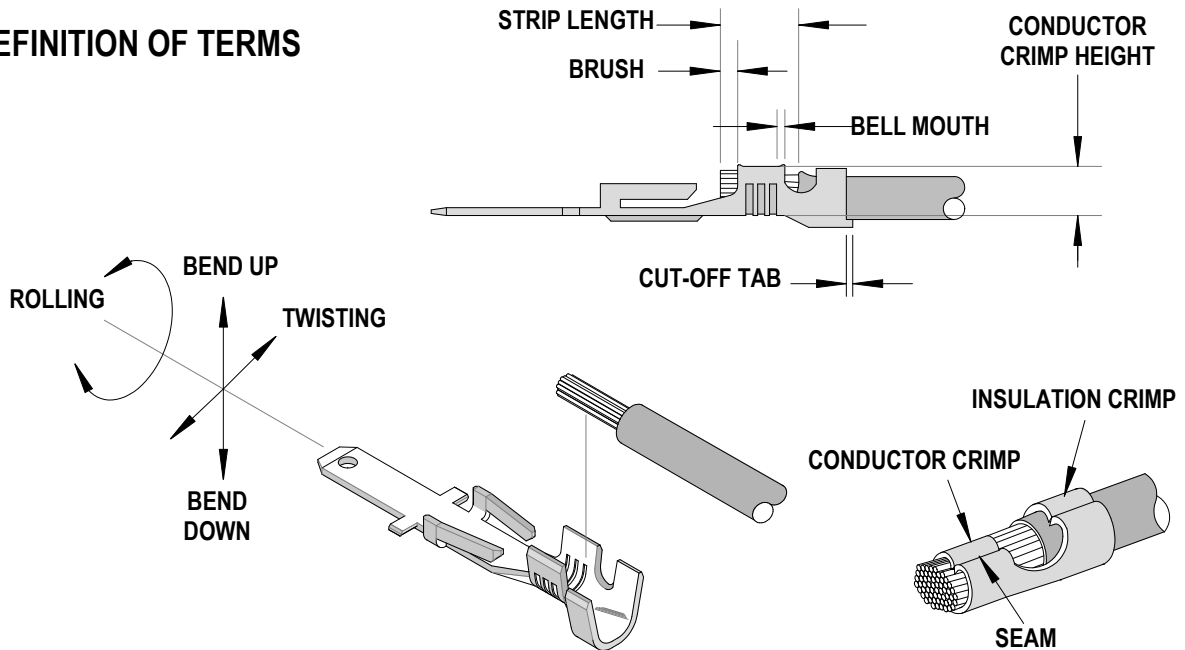

### CRIMP SPECIFICATIONS

Terminal Series No.	Bell mouth		Cut-off Tab Maximum		Conductor Brush	
	mm	In.	mm	In.	mm	In.
43178	0.25-1.00	.010-.039	0.50	.019	1.50	.059

Terminal Series No.	Bend up	Bend down	Twist	Roll	Punch Width (Ref)				Seam Seam shall not be open and no wire allowed out of the crimping area
	Degree		Degree		Conductor		Insulation		
					mm	In	mm	In	
43178	3	3	4	8	3.40	.133	4.80	.189	

After crimping, the conductor profile should measure the following.

Terminal Series No.	Wire Size		Crimp Height		Pull Force Minimum	
	AWG	mm <sup>2</sup>	mm	In.	N	Lb.
43178	14	2.00	1.80-1.90	.071-.075	222.0	50.0
	16	1.30	1.70-1.80	.067-.071	133.0	30.0

Pull Force should be measured with no influence from the insulation crimp.

The above specifications are guidelines to an optimum crimp.

**PARTS LIST**

<b>Mini-Mac Applicator 63891-9100</b>				
<b>Item</b>	<b>Order No</b>	<b>Engineering No.</b>	<b>Description</b>	<b>Quantity</b>
<b>Perishable Tooling</b>				
	63891-9170	63891-9170	Tool Kit (All "Y" Items)	REF
1	63830-4001	63830-4001	Conductor Punch	1 Y
2	63445-3443	63445-3443	Conductor Anvil	1 Y
3	11-18-5417	60842B108	Insulation Punch	1 Y
4	63445-4814	63445-4814	Insulation Anvil	1 Y
5	63443-0047	63443-0047	Front Cut-Off Plunger	1 Y
6	63443-0012	63443-0012	Cut-off Plunger Retainer	1 Y
<b>Other Components</b>				
7	11-18-5442	60843A123	Front Cover	1
8	63443-0009	63443-0009	Scrap Shield	1
9	63443-0021	63443-0021	Lower Tooling Key	1
10	63443-0090	63443-0090	Wire Stop	1
11	63443-6121	63443-6121	Rear Cover	1
12	63700-0539	63700-0539	Heavy Duty Cut-off Plunger Spring	1
13	63803-5118	63803-5118	Conductor Bushing	1
14	63830-3005	63830-3005	Tooling Washer	1
15	63830-3006	63830-3006	Front Plunger Striker	1
16	63830-4002	63830-4002	Anvil Mount	1
<b>Frame</b>				
17	63801-3201	63801-3201	Top	1
18	63801-3282	63801-3282	Base	1
19	63801-6550	63801-6550	Track	1
<b>Hardware</b>				
20	N/A	N/A	M3 by 6 Long SHCS	2**
21	N/A	N/A	M4 by 6 Long SHCS	2**
22	N/A	N/A	M4 by 8 Long BHCS	4**
23	N/A	N/A	M4 by 12 Long BHCS	2**
24	N/A	N/A	M4 by 25 Long SHCS	2**
25	N/A	N/A	M5 by 12 Long SHCS	1**
26	N/A	N/A	M8 by 20 Long BHCS	1**
27	N/A	N/A	3MM by 6 Long Roll Pin	1**
** Available from an industrial supply company such as MSC (1-800-645-7270).				

### Assembly Drawing

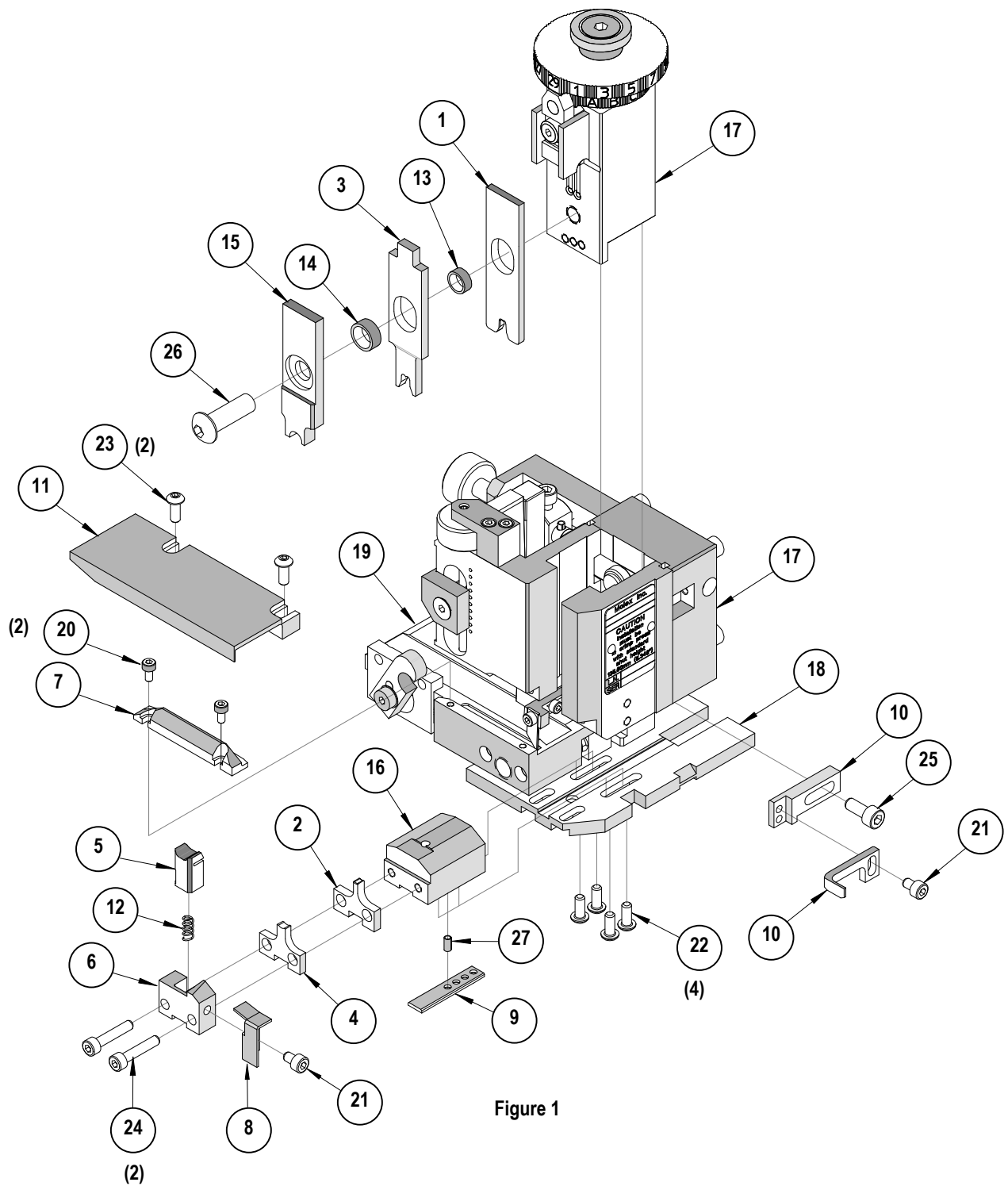

Figure 1

## NOTES

1. Molex recommends an extra perishable tooling kit be maintained at your facility.
2. Verify tooling alignment by manually cycling the press and applicator before crimping under power. Check that all screws are tight.
3. Slugs, terminals, dirt, and oil should be kept clear of work area.
4. Wear safety glasses at all times.
5. For recommended maintenance refer to the Mini-Mac Manual.

**CAUTION:** This applicator should only be used in a press with a shut height of 135.80 mm (5.346"). Tooling damage could result at a lower setting

**CAUTION:** To prevent injury, never operate this applicator without the guards supplied with the press or wire-processing machine in place. Reference the press or wire processing manufacturer's instruction manual.

**CAUTION:** Molex crimp specifications are valid only when used with Molex terminals, applicators and tooling.

## Contact Information

For more information on Molex application tooling please contact Molex at 1-800-786-6539.

Visit our Web site at <http://www.molex.com>