

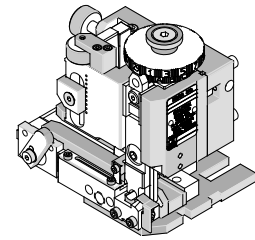

Mini-Mac  
Applicator

## Application Tooling Specification Sheet



Order No. 63888-1100

### FEATURES

- Directly adapts to most automatic wire processing machines
- Applicator designed to industry standard mounting and shut height 135.80mm (5.346")
- Quick set-up time; plus the crimp height, track and feed adjustments can be set without removing the applicator from the press
- Fine adjustment allows users to achieve target with little effort by adjusting in increments of .015mm (.0006") for conductor crimp height and .063mm (.0025") for insulation height
- Independent adjustment rings allow users to quickly adjust the conductor or insulation crimp height without affecting each other

### SCOPE

Products: KK® 3.96mm (.156") Center Crimp Terminal, 18-24 AWG.

Terminal Series No.	Terminal Order No.			Wire Size		Insulation Diameter Maximum		Strip Length	
				AWG	mm <sup>2</sup>	mm	In.	mm	In.
8818	08-50-0008	08-56-0187	40-01-1181	18-24	0.82-0.20	2.79	.110	2.54-3.18	.100-.125
	08-50-0705	08-58-0135	40-01-1182						
	08-52-0131	08-65-0128							

### DEFINITION OF TERMS

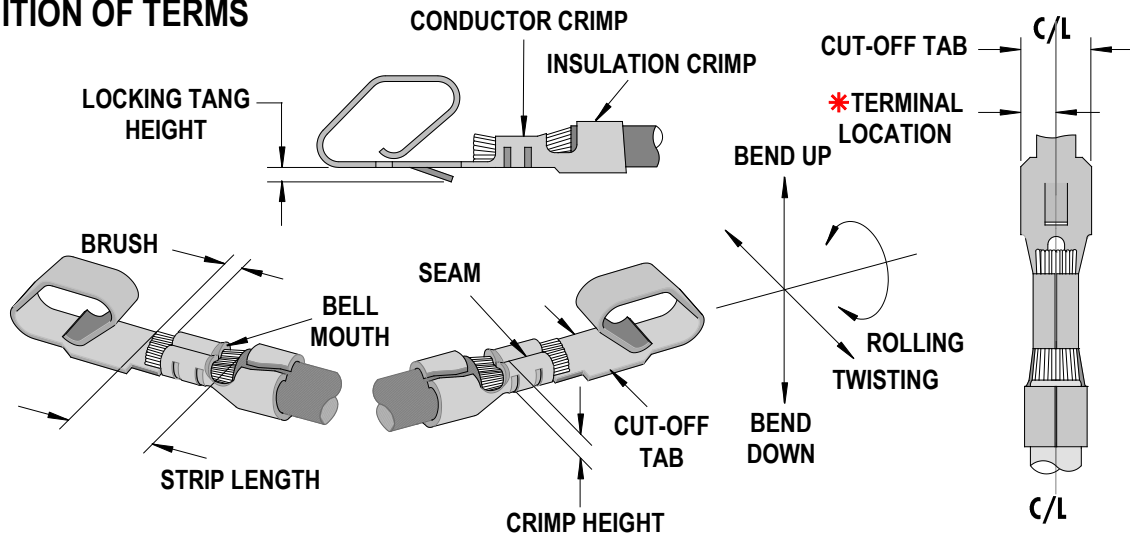

\* Terminal is to be centrally located between the two (2) cut-off tab edges by one half of the total cut-off tab tolerance.

This illustration is a generic terminal representation and not an exact image of any terminal listed in the scope.

## CRIMP SPECIFICATIONS

Terminal Series No.	Bell mouth		*Cut-off Tab		Conductor Brush	
	mm	In.	mm	In.	mm	In.
8818			2.64-2.80	.104-.110		

Terminal Series No.	Locking Tang Height		Bend up	Bend down	Twist	Roll	Punch Width (Ref)				Seam Seam shall not be open and no wire allowed out of the crimping area
	mm	In	Degree		Degree		Conductor		Insulation		
8818	0.64-0.76	.025-.030					mm	In	mm	In	
							1.925	.076	2.45	.096	

**NOTE:** Some of the specifications in these charts above are intentionally left blank due to the fact that the information does not currently exist.

After crimping, the conductor profile should measure the following.

Terminal Series No.	Wire Size		Crimp Height		Crimp Width (Ref)		Pull Force Minimum	
	AWG	mm <sup>2</sup>	mm	In.	mm	In.	N	Lb.
8818	18	0.82	1.09-1.14	.043-.045			111.20	25.0
	20	0.52	1.02-1.09	.040-.043			66.72	15.0
	22	0.35	0.96-1.02	.038-.040			53.38	12.0
	24	0.20	0.91-0.96	.036-.038			44.48	10.0

### Tool Qualification Notes:

1. Pull Force should be measured with no influence from the insulation crimp.
2. The above specifications are guidelines to an optimum crimp.

### Terminal Strip Adjustment

The terminal strip hole must be aligned to the pilot pin before crimping under power. Hand cycle the press several times to check the alignment of the pilot pin to the terminal strip hole before crimping under power. Use the track adjusting screw and the terminal position adjusting knob to align the terminal strip hole to the pilot pin.

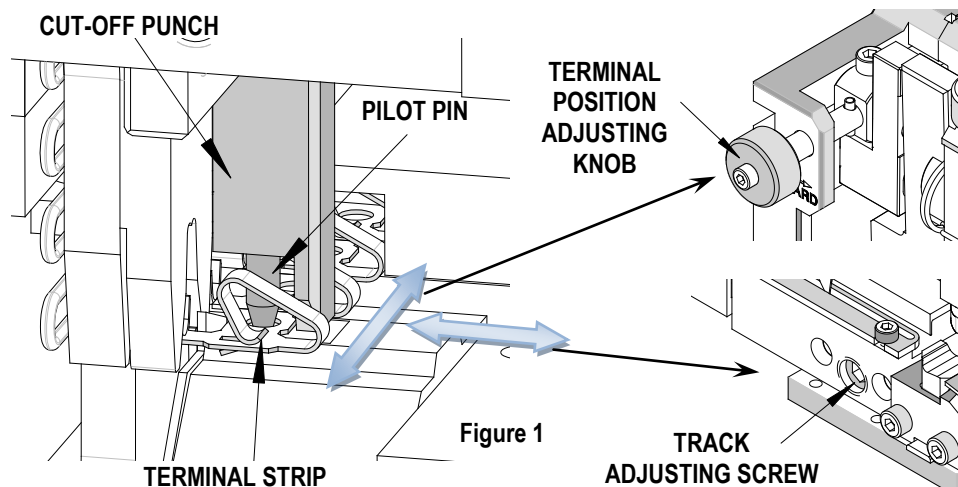

**PARTS LIST**

<b>Mini-Mac Applicator 63888-1100</b>				
<b>Item</b>	<b>Order No</b>	<b>Engineering No.</b>	<b>Description</b>	<b>Quantity</b>
<b>Perishable Tooling</b>				
	63888-1170	63888-1170	Tool Kit (All "Y" Items)	REF
1	11-18-4784	60712C106	Conductor Punch	1 Y
2	11-18-4785	60712C107	Conductor Anvil	1 Y
3	11-18-4786	60712C108	Insulation Punch	1 Y
4	11-18-4111	60712-11	Insulation Anvil	1 Y
5	63820-0042	63820-0042	Cut-Off Punch	1 Y
6	11-18-4470	60712-24	Cut-Off Insert	1 Y
<b>Other Components</b>				
7	11-18-4006	60703-8	Stripper Blade Holder	1
8	11-18-4103	60712-3	Cover Plate	1
9	11-18-4106	60712-6	Insulation Punch Spacer	1
10	11-18-4332	60703-16	Stripper	1
11	11-18-4471	60712-25	Retainer Block	1
12	11-18-5015	60805A122	Front Cover	1
13	11-40-4085	8301-10	Terminal Stop and Scrap Shield	1
14	63600-4664	63600-4664	Compression Spring	2
15	63803-5103	63803-5103	Conductor Bushing	1
16	63820-0012	63820-0012	Cover-Drag Frame	1
<b>Frame</b>				
17	63801-3201	63801-3201	Top	1
18	63801-3283	63801-3283	Base	1
19	63801-6950	63801-6950	Track	1
<b>Hardware</b>				
20	N/A	N/A	M3 by 6 Long SHCS	2**
21	N/A	N/A	M3 by 8 Long SHCS	2**
22	N/A	N/A	M4 by 6 Long SHCS	2**
23	N/A	N/A	M4 by 12 Long BHCS	2**
24	N/A	N/A	M5 by 10 Long SHCS	1**
25	N/A	N/A	M8 by 20 Long BHCS	1**
26	N/A	N/A	#4-40 by .19" Long SHCS	2**
27	N/A	N/A	#6-32 by 3/8" Long BHCS	2**
28	N/A	N/A	#10-32 by 1.120" Long SHCS	1**
** Available from an industrial supply company such as MSC (1-800-645-7270).				

# Assembly Drawing

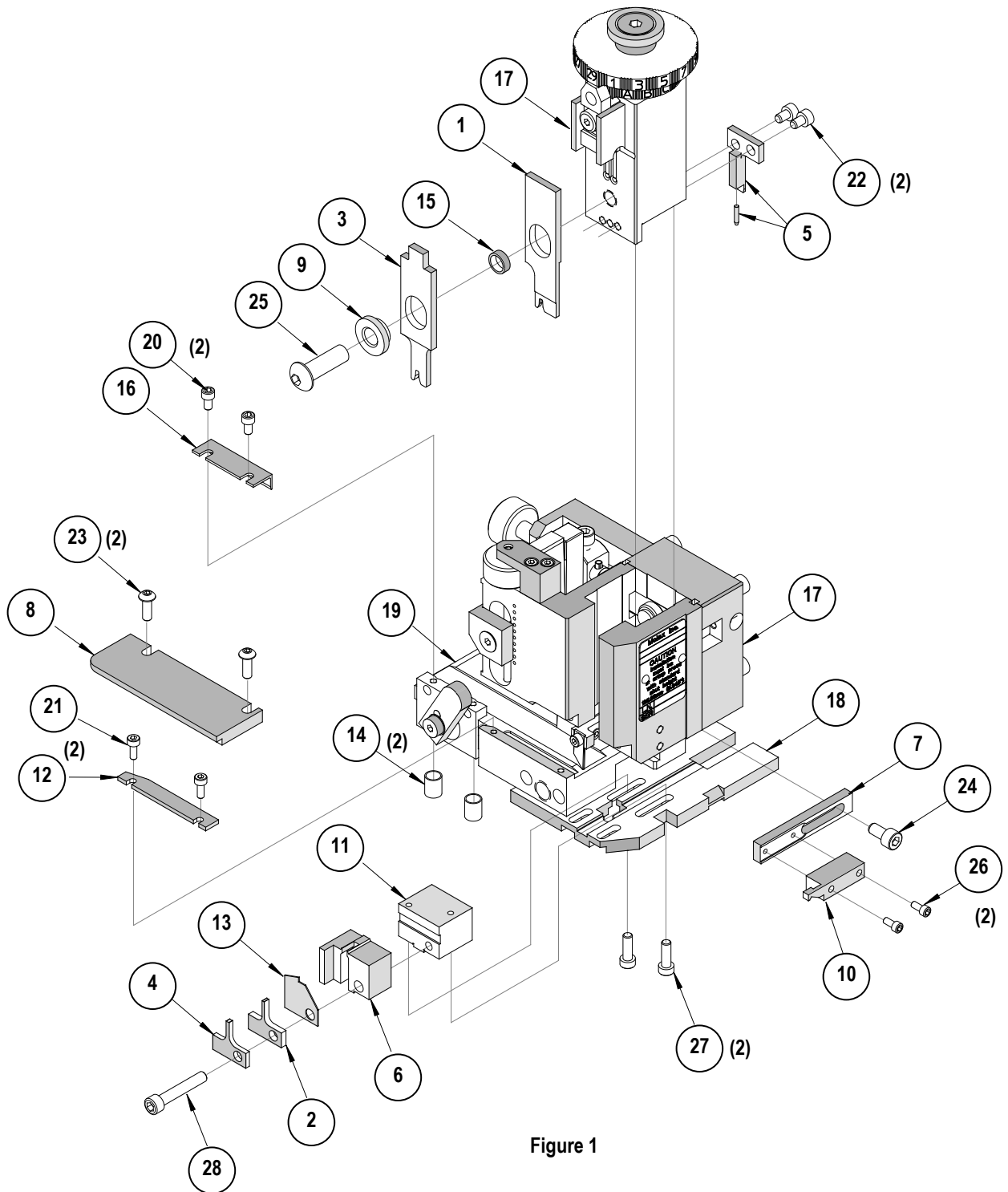

Figure 1

## NOTES

1. Molex recommends an extra perishable tooling kit be maintained at your facility.
2. Verify tooling alignment by manually cycling the press and Applicator before crimping under power. Check that all screws are tight.
3. Slugs, Terminals, Dirt and Oil should be kept clear of work area.
4. Wear safety glasses at all times.
5. For recommended maintenance refer to the Mini-Mac Manual.

**CAUTION:** This applicator should only be used in a press with a shut height of 135.8 mm (5.346"). Tooling damage could result at a lower setting.

**CAUTION:** To prevent injury never operate this Applicator without the guards supplied with the press or wire-processing machine in place. Reference the press or wire processing manufacturer's instruction manual.

**CAUTION:** Molex crimp specifications are valid only when used with Molex terminals, applicators and tooling.

Visit our Web site at <http://www.molex.com>