

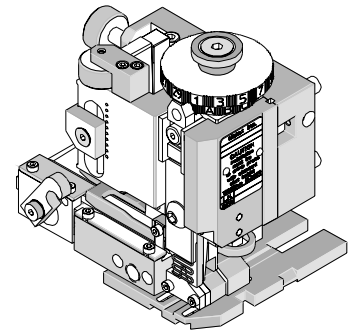

# Mini-Mac Applicator Specification Sheet Order No. 63892-8100



## FEATURES

- Directly adapts to most automatic wire processing machines
- Applicator designed to industry standard mounting and shut height 135.80mm (5.346")
- Quick set-up time; plus the crimp height, track and feed adjustments can be set without removing the applicator from the press
- Fine adjustment allows users to achieve target with little effort by adjusting in increments of .015mm (.0006") for conductor crimp height and .063mm (.0025") for insulation height
- Independent adjustment rings allow users to quickly adjust the conductor or insulation crimp height without affecting each other.

## SCOPE

Products: 3.18mm (.125") Diameter HCS-125, Pin and Socket Male and Female Crimp Terminal, 10-14 AWG.

Terminal Series No.	Terminal Order No.	Wire Size		Insulation Diameter		Strip Length	
		AWG	mm <sup>2</sup>	mm	In.	mm	In.
1900	18-12-2601	10-14 and (1) 12+ (1) 18	5.0-2.0	4.57	.180 Max.	4.06-5.59	.160-.220
1901	18-12-1601	10-14 and (1) 12+ (1) 18	5.0-2.0	4.57	.180 Max.	4.06-5.59	.160-.220

## DEFINITION OF TERMS

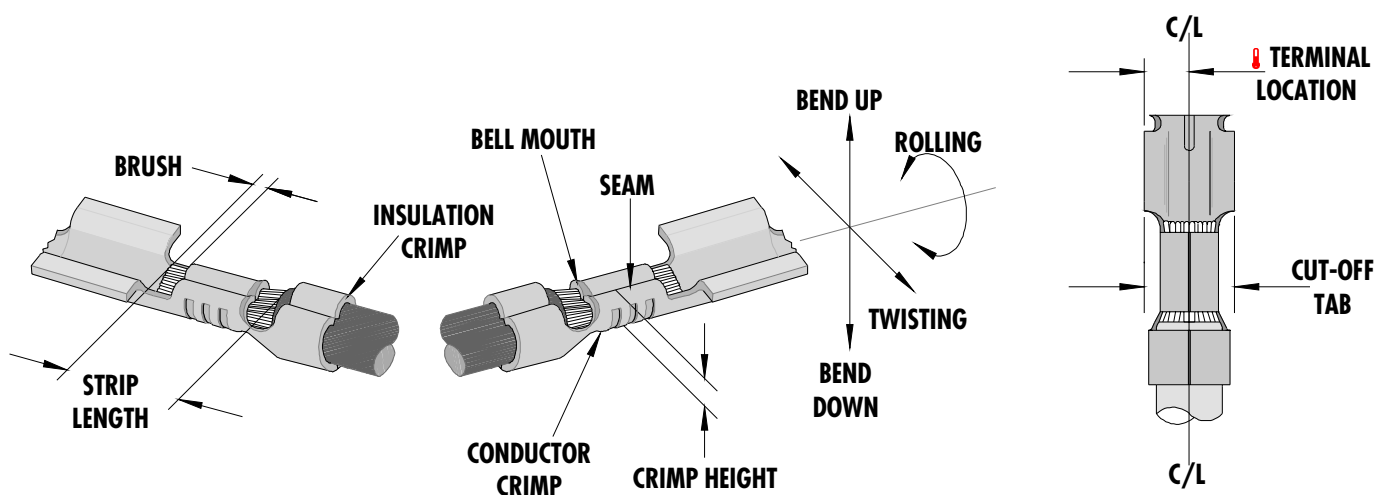

⚠ Terminal is to be centrally located between the two (2) cut-off tab edges by one half of the total cut-off tab tolerance. This illustration is a generic terminal representation and not an exact image of any terminal listed in the scope.

## CRIMP SPECIFICATIONS

Terminal Series No.	Bell mouth		⚠ Cut-off Tab		Conductor Brush	
	mm	In.	mm	In.	mm	In.
1900			5.00-5.16	.197-.203		
1901			5.00-5.16	.197-.203		

Terminal Series No.	Bend up	Bend down	Twist	Roll	Punch Width (Ref)				Seam
	Degree		Degree		Conductor		Insulation		
					mm	In.	mm	In.	
1900					3.85	.152	5.00	.197	Seam shall not be open and no wire allowed out of the crimping area
1901					3.85	.152	5.00	.197	

**NOTE:** Some of the specifications in these charts above are intentionally left blank due to the fact that the information does not currently exist.

After crimping, the conductor profile should measure the following.

Terminal Series No.	Wire Size		Conductor				Pull Force Minimum	
	AWG	mm <sup>2</sup>	Crimp Height		Crimp width (REF)		N	Lb.
			mm	In.	mm	In.		
1900	10	5.00	2.03-2.16	.080-.085			356.0	80.0
	12	3.30	1.96-2.08	.077-.082			311.4	70.0
	14	2.00	1.80-1.91	.071-.075			266.9	60.0
	⚠ ⚠ (1) 12 + (1) 18	3.30+0.80	2.03-2.16	.080-.085			89.0	20.0
1901	10	5.00	2.03-2.16	.080-.085			356.0	80.0
	12	3.30	1.96-2.08	.077-.082			311.4	70.0
	14	2.00	1.80-1.91	.071-.075			266.9	60.0
	⚠ ⚠ (1) 12 + (1) 18	3.30+0.80	2.03-2.16	.080-.085			89.0	20.0

⚠ ⚠ **For Double Application:** Position smaller wire size on the bottom and larger wire size on top.

Pull Force should be measured with no influence from the insulation crimp.  
The above specifications are guidelines to an optimum crimp.

**PARTS LIST**

<b>Mini-Mac Applicator 63892-8100</b>				
<b>Item</b>	<b>Order No</b>	<b>Engineering No.</b>	<b>Description</b>	<b>Quantity</b>
<b>Perishable Tooling</b>				
	63892-8170	63892-8170	Tool Kit (All "Y" Items)	REF
1	11-18-4986	60805B106	Conductor Punch	1 Y
2	11-18-4987	60805B107	Conductor Anvil	1 Y
3	11-18-4988	60805B108	Insulation Punch	1 Y
4	11-18-4989	60805B109	Insulation Anvil	1 Y
5	11-18-4977	60805A104	Cut-Off Punch	1 Y
6	11-18-4983	60805A111	Rear Cut-off Die Blade	1 Y
<b>Other Components</b>				
7	11-18-4810	60800A106	Rear Block	1
8	11-18-4811	60800A107	Compression Spring	1
9	11-18-4815	60800A111	Guide Plate	1
10	11-18-4816	60800A112	Terminal Drag Plate	1
11	11-18-4818	60800A114	Mounting Block	1
12	11-18-4829	60800A125	Wire Stop	1
13	11-18-4848	60800A123	Spring Retainer	1
14	11-18-4849	60800A124	Wire Hold Down Spring	1
15	11-18-4894	60800A129	Knockout Spring	1
16	11-18-4984	60805A112	Plunger	1
17	11-18-4985	60805A115	Tooling Washer	1
18	11-18-5005	60800D112	Hold Down Block	1
19	11-18-5006	60800D113	Spring Retainer	1
20	11-18-5007	60800D114	Compression Spring (Hold Down)	1
21	11-18-5014	60805A121	Hold Down Plunger	1
22	11-18-5015	60805A122	Front Cover	1
23	63803-5111	63803-5111	Conductor Bushing	1
<b>Frame</b>				
24	63801-3201	63801-3201	Top	1
25	63801-3282	63801-3282	Base	1
26	63801-6550	63801-6550	Track	1
<b>Hardware</b>				
27	N/A	N/A	M3 by 6 Long SHCS	6**
28	N/A	N/A	M3 by 25 Long SHCS	2**
29	N/A	N/A	M4 by 6 Long BHCS	2**
30	N/A	N/A	M4 by 10 Long BHCS	4**
31	N/A	N/A	M4 by 18 Long SHCS	2**
32	N/A	N/A	M5 by 10 Long SHCS	1**
33	N/A	N/A	M8 by 20 Long BHCS	1**
** Available from an industrial supply company such as MSC (1-800-645-7270).				

