

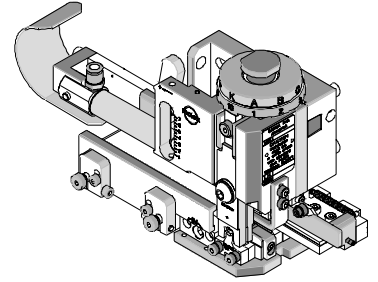

Mini-Mac Applicator Application Tooling Specification Air Feed-Mylar Tape Order No. 63885-0400



FEATURES

- Directly adapts to most crimp presses and automatic wire processors
- Applicator designed to industry standard mounting and shut height of 135.80mm (5.346")
- Conductor and insulation rings allow quick adjustment for conductor and insulation crimp height change
- Quick set-up time; plus the crimp height, track and feed adjustments can be set without removing the applicator from the crimp press

SCOPE

Products: Ring and Spade Terminals 14-16 AWG

Testing

Mechanical

The tensile test, or pull test, is a means of evaluating the mechanical properties of the crimped connections. The following chart shows the UL and government specifications (MIL-T-7928) for various wire sizes. The tensile strength is shown in pounds and indicates the minimum acceptable force to break or separate the terminal from the conductor.

Color Code	Wire Size (AWG)	*UL - 486 A	*UL - 486 C	*UL - 310	*Military Class 2
Yellow	26	3	N/A	N/A	7
Yellow	24	5	N/A	N/A	10
Red	22	8	8	8	15
Red	20	13	10	13	19
Red	18	20	10	20	38
Blue	16	30	15	30	50
Blue	14	50	25	50	70
Yellow	12	70	35	70	110
Yellow	10	80	40	80	150
Red	8	90	45	N/A	225
Blue	6	100	50	N/A	300

*UL - 486 A - Terminals (Copper conductors only)

*UL - 486 C - Butt Splices, Parallel Splices, Closed End Connectors, and Wire Nuts

*UL - 310 - Quick Disconnects, Flag and Couplers

*Military Class 2 - Military Approved Terminals only as listed

Product List

The following is a partial list of the product order numbers and their specifications that this tool is designed to run. Updates to this list are available on www.molex.com.

Terminal No.	Terminal Eng. No.	Wire Size		Insulation Diameter Max.		Strip Length	
		AWG	mm ²	mm	In.	mm	In.
19023-0017	MMCT-2XT	14-16	2.00-1.30	4.45	.175	5.95	.234
19025-0011	MMCT-5T	14-16	2.00-1.30	4.32	.170	5.95	.234
19026-0009	MMCT-8T	14-16	2.00-1.30	4.32	.170	5.95	.234
19070-0055	BB-218-10XT	14-16	2.00-1.30	4.45	.175	5.95	.234
19070-0058	BB-218-14XT	14-16	2.00-1.30	4.45	.175	5.95	.234
19070-0061	BB-218-38XT	14-16	2.00-1.30	4.45	.175	5.95	.234
19070-0064	BB-218-56XT	14-16	2.00-1.30	4.45	.175	5.95	.234
19070-0066	BB-223-02XT	14-16	2.00-1.30	4.45	.175	5.95	.234
19070-0068	BB-223-04XT	14-16	2.00-1.30	4.45	.175	5.95	.234
19070-0070	BB-223-06XT	14-16	2.00-1.30	4.45	.175	5.95	.234
19070-0072	BB-223-08XT	14-16	2.00-1.30	4.45	.175	5.95	.234
19070-0074	BB-225-10XT	14-16	2.00-1.30	4.45	.175	5.95	.234
19070-0076	BB-225-14XT	14-16	2.00-1.30	4.45	.175	5.95	.234
19070-0079	BB-225-56XT	14-16	2.00-1.30	4.45	.175	5.95	.234
19070-0082	BB-237-04XT	14-16	2.00-1.30	4.45	.175	5.95	.234
19070-0084	BB-237-06XT	14-16	2.00-1.30	4.45	.175	5.95	.234
19070-0085	BB-237-06XXT	14-16	2.00-1.30	4.45	.175	5.95	.234
19070-0087	BB-237-08XT	14-16	2.00-1.30	4.45	.175	5.95	.234
19070-0092	BB-237-10XT	14-16	2.00-1.30	4.45	.175	5.95	.234
19070-0096	BB-239-04XT	14-16	2.00-1.30	4.45	.175	5.95	.234
19070-0098	BB-239-06XT	14-16	2.00-1.30	4.45	.175	5.95	.234
19070-0100	BB-239-08XT	14-16	2.00-1.30	4.45	.175	5.95	.234
19070-0104	BB-239-10XT	14-16	2.00-1.30	4.45	.175	5.95	.234
19071-0043	BB-618-10XT	14-16	2.00-1.30	4.45	.175	5.95	.234
19071-0045	BB-618-14XT	14-16	2.00-1.30	4.45	.175	5.95	.234
19071-0047	BB-618-38XT	14-16	2.00-1.30	4.45	.175	5.95	.234
19071-0050	BB-618-56XT	14-16	2.00-1.30	4.45	.175	5.95	.234
19071-0052	BB-623-02XT	14-16	2.00-1.30	4.45	.175	5.95	.234
19071-0054	BB-623-04XT	14-16	2.00-1.30	4.45	.175	5.95	.234
19071-0056	BB-623-06XT	14-16	2.00-1.30	4.45	.175	5.95	.234
19071-0058	BB-623-08XT	14-16	2.00-1.30	4.45	.175	5.95	.234
19071-0059	BB-623-125XT	14-16	2.00-1.30	4.45	.175	5.95	.234
19071-0061	BB-625-10XT	14-16	2.00-1.30	4.45	.175	5.95	.234
19071-0063	BB-625-14XT	14-16	2.00-1.30	4.45	.175	5.95	.234
19071-0065	BB-625-56XT	14-16	2.00-1.30	4.45	.175	5.95	.234
19071-0067	BB-637-04XT	14-16	2.00-1.30	4.45	.175	5.95	.234
19071-0069	BB-637-06XT	14-16	2.00-1.30	4.45	.175	5.95	.234
19071-0071	BB-637-08XT	14-16	2.00-1.30	4.45	.175	5.95	.234
19071-0073	BB-637-10XT	14-16	2.00-1.30	4.45	.175	5.95	.234
19071-0076	BB-639-04XT	14-16	2.00-1.30	4.45	.175	5.95	.234
19071-0078	BB-639-06XT	14-16	2.00-1.30	4.45	.175	5.95	.234
19071-0080	BB-639-08XT	14-16	2.00-1.30	4.45	.175	5.95	.234
19071-0082	BB-639-10XT	14-16	2.00-1.30	4.32	.170	6.35	.250
19073-0057	BB-818-10T	14-16	2.00-1.30	4.32	.170	6.35	.250
19073-0058	BB-818-14T	14-16	2.00-1.30	4.32	.170	6.35	.250
19073-0060	BB-818-38T	14-16	2.00-1.30	4.32	.170	6.35	.250
19073-0062	BB-818-56T	14-16	2.00-1.30	4.32	.170	6.35	.250
19073-0064	BB-823-02T	14-16	2.00-1.30	4.32	.170	6.35	.250
19073-0066	BB-823-04T	14-16	2.00-1.30	4.32	.170	6.35	.250
19073-0070	BB-823-06T	14-16	2.00-1.30	4.32	.170	6.35	.250
19073-0073	BB-823-08T	14-16	2.00-1.30	4.45	.175	5.95	.234
19073-0075	BB-825-10T	14-16	2.00-1.30	4.45	.175	5.95	.234
19073-0077	BB-825-14T	14-16	2.00-1.30	4.45	.175	5.95	.234
19073-0078	BB-825-38T	14-16	2.00-1.30	4.45	.175	5.95	.234
19073-0080	BB-825-56T	14-16	2.00-1.30	4.45	.175	5.95	.234

Terminal No.	Terminal Eng. No.	Wire Size		Insulation Diameter Max.		Strip Length	
		AWG	mm ²	mm	In.	mm	In.
19073-0082	BB-837-04T	14-16	2.00-1.30	4.45	.175	5.95	.234
19073-0084	BB-837-06T	14-16	2.00-1.30	4.45	.175	5.95	.234
19073-0086	BB-837-08T	14-16	2.00-1.30	4.45	.175	5.95	.234
19073-0088	BB-837-10T	14-16	2.00-1.30	4.45	.175	5.95	.234
19073-0092	BB-839-04T	14-16	2.00-1.30	4.45	.175	5.95	.234
19073-0093	BB-839-06T	14-16	2.00-1.30	4.45	.175	5.95	.234
19073-0096	BB-839-08T	14-16	2.00-1.30	4.45	.175	5.95	.234
19073-0099	BB-839-10T	14-16	2.00-1.30	4.45	.175	5.95	.234
19090-0045	BB-213-04XT	14-16	2.00-1.30	4.45	.175	5.95	.234
19090-0047	BB-213-06XT	14-16	2.00-1.30	4.45	.175	5.95	.234
19090-0049	BB-213-08XT	14-16	2.00-1.30	4.45	.175	5.95	.234
19090-0053	BB-282-06XT	14-16	2.00-1.30	4.45	.175	5.95	.234
19090-0055	BB-282-08XT	14-16	2.00-1.30	4.45	.175	5.95	.234
19090-0057	BB-282-10XT	14-16	2.00-1.30	4.45	.175	5.95	.234
19090-0062	BB-285-06XT	14-16	2.00-1.30	4.45	.175	5.95	.234
19090-0064	BB-285-08XT	14-16	2.00-1.30	4.45	.175	5.95	.234
19090-0066	BB-285-10XT	14-16	2.00-1.30	4.45	.175	5.95	.234
19090-0070	BB-288-04XT	14-16	2.00-1.30	4.45	.175	5.95	.234
19090-0072	BB-288-06XT	14-16	2.00-1.30	4.45	.175	5.95	.234
19090-0074	BB-288-08XT	14-16	2.00-1.30	4.45	.175	5.95	.234
19090-0076	BB-288-10XT	14-16	2.00-1.30	4.32	.170	6.35	.250
19092-0040	BB-613-04XT	14-16	2.00-1.30	4.32	.170	6.35	.250
19092-0042	BB-613-06XT	14-16	2.00-1.30	4.32	.170	6.35	.250
19092-0044	BB-613-08XT	14-16	2.00-1.30	4.32	.170	6.35	.250
19092-0046	BB-682-06XT	14-16	2.00-1.30	4.32	.170	6.35	.250
19092-0048	BB-682-08XT	14-16	2.00-1.30	4.32	.170	6.35	.250
19092-0050	BB-682-10XT	14-16	2.00-1.30	4.32	.170	6.35	.250
19092-0052	BB-685-06XT	14-16	2.00-1.30	4.32	.170	6.35	.250
19092-0054	BB-685-08XT	14-16	2.00-1.30	4.45	.175	5.95	.234
19092-0056	BB-685-10XT	14-16	2.00-1.30	4.45	.175	5.95	.234
19092-0058	BB-688-04XT	14-16	2.00-1.30	4.45	.175	5.95	.234
19092-0060	BB-688-06XT	14-16	2.00-1.30	4.45	.175	5.95	.234
19092-0062	BB-688-08XT	14-16	2.00-1.30	4.45	.175	5.95	.234
19092-0064	BB-688-10XT	14-16	2.00-1.30	4.45	.175	5.95	.234
19095-0057	BB-813-04T	14-16	2.00-1.30	4.32	.170	6.35	.250
19095-0059	BB-813-06T	14-16	2.00-1.30	4.32	.170	6.35	.250
19095-0061	BB-813-08T	14-16	2.00-1.30	4.32	.170	6.35	.250
19095-0069	BB-882-06T	14-16	2.00-1.30	4.32	.170	6.35	.250
19095-0071	BB-882-08T	14-16	2.00-1.30	4.32	.170	6.35	.250
19095-0073	BB-882-10T	14-16	2.00-1.30	4.32	.170	6.35	.250
19095-0082	BB-885-06T	14-16	2.00-1.30	4.32	.170	6.35	.250
19095-0084	BB-885-08T	14-16	2.00-1.30	4.32	.170	6.35	.250
19095-0086	BB-885-10T	14-16	2.00-1.30	4.32	.170	6.35	.250
19095-0092	BB-888-04T	14-16	2.00-1.30	4.32	.170	6.35	.250
19095-0094	BB-888-06T	14-16	2.00-1.30	4.32	.170	6.35	.250
19095-0096	BB-888-08T	14-16	2.00-1.30	4.32	.170	6.35	.250
19095-0098	BB-888-10T	14-16	2.00-1.30	4.32	.170	6.35	.250
19099-0018	BB-2193-06XT	14-16	2.00-1.30	4.45	.175	5.95	.234
19099-0020	BB-2194-08XT	14-16	2.00-1.30	4.45	.175	5.95	.234
19099-0024	BB-2195-10XT	14-16	2.00-1.30	4.45	.175	5.95	.234
19099-0026	BB-2707-05XT	14-16	2.00-1.30	4.45	.175	5.95	.234
19099-0028	BB-2707-06XT	14-16	2.00-1.30	4.45	.175	5.95	.234
19099-0033	BB-2716-08XT	14-16	2.00-1.30	4.45	.175	5.95	.234
19099-0035	BB-2717-10XT	14-16	2.00-1.30	4.45	.175	5.95	.234
19099-0057	BB-2707-04XT	14-16	2.00-1.30	4.45	.175	5.95	.234

Air Feed Mylar Tape Applicator

Terminal No.	Terminal Eng. No.	Wire Size		Insulation Diameter Max.		Strip Length	
		AWG	mm ²	mm	In.	mm	In.
19115-0017	BB-8193-06T	14-16	2.00-1.30	4.45	.175	6.35	.250
19115-0019	BB-8194-08T	14-16	2.00-1.30	4.45	.175	6.35	.250
19115-0021	BB-8195-10T	14-16	2.00-1.30	4.45	.175	6.35	.250
19115-0023	BB-8707-05T	14-16	2.00-1.30	4.45	.175	6.35	.250
19115-0025	BB-8707-06T	14-16	2.00-1.30	4.45	.175	6.35	.250
19115-0030	BB-8716-08T	14-16	2.00-1.30	4.45	.175	6.35	.250
19115-0032	BB-8717-10T	14-16	2.00-1.30	4.45	.175	6.35	.250
19115-0054	BB-8707-04T	14-16	2.00-1.30	4.45	.175	6.35	.250
19121-0027	BB-216-06XT	14-16	2.00-1.30	4.45	.175	5.95	.234
19121-0029	BB-216-08XT	14-16	2.00-1.30	4.45	.175	5.95	.234
19121-0031	BB-216-10XT	14-16	2.00-1.30	4.45	.175	5.95	.234
19121-0041	BB-283-10XT	14-16	2.00-1.30	4.45	.175	5.95	.234
19121-0072	BB-216-04XT	14-16	2.00-1.30	4.45	.175	5.95	.234
19121-0074	BB-2491-06XT	14-16	2.00-1.30	4.45	.175	5.95	.234
19121-0075	BB-2491-08XT	14-16	2.00-1.30	4.45	.175	5.95	.234
19121-0076	BB-280-06XT	14-16	2.00-1.30	4.45	.175	5.95	.234
19121-0077	BB-280-08XT	14-16	2.00-1.30	4.45	.175	5.95	.234
19121-0078	BB-280-10XT	14-16	2.00-1.30	4.45	.175	5.95	.234
19121-0079	BB-283-06XT	14-16	2.00-1.30	4.45	.175	5.95	.234
19121-0080	BB-283-08XT	14-16	2.00-1.30	4.45	.175	5.95	.234
19121-0081	BB-286-04XT	14-16	2.00-1.30	4.45	.175	5.95	.234
19121-0082	BB-286-06XT	14-16	2.00-1.30	4.45	.175	5.95	.234
19121-0083	BB-286-08XT	14-16	2.00-1.30	4.45	.175	5.95	.234
19122-0030	BB-616-04XT	14-16	2.00-1.30	4.45	.175	5.95	.234
19122-0032	BB-616-06XT	14-16	2.00-1.30	4.45	.175	5.95	.234
19122-0034	BB-616-08XT	14-16	2.00-1.30	4.45	.175	5.95	.234
19122-0035	BB-616-10XT	14-16	2.00-1.30	4.45	.175	5.95	.234
19122-0037	BB-680-06XT	14-16	2.00-1.30	4.45	.175	5.95	.234
19122-0039	BB-680-08XT	14-16	2.00-1.30	4.45	.175	5.95	.234
19122-0041	BB-680-10XT	14-16	2.00-1.30	4.45	.175	5.95	.234
19122-0043	BB-683-06XT	14-16	2.00-1.30	4.45	.175	5.95	.234
19122-0045	BB-683-08XT	14-16	2.00-1.30	4.45	.175	5.95	.234
19122-0047	BB-683-10XT	14-16	2.00-1.30	4.45	.175	5.95	.234
19122-0049	BB-686-04XT	14-16	2.00-1.30	4.45	.175	5.95	.234
19122-0051	BB-686-06XT	14-16	2.00-1.30	4.45	.175	5.95	.234
19122-0053	BB-686-08XT	14-16	2.00-1.30	4.45	.175	5.95	.234
19127-0038	BB-816-04T	14-16	2.00-1.30	4.32	.170	6.35	.250
19127-0041	BB-816-06T	14-16	2.00-1.30	4.32	.170	6.35	.250
19127-0044	BB-816-08T	14-16	2.00-1.30	4.32	.170	6.35	.250
19127-0045	BB-816-10T	14-16	2.00-1.30	4.32	.170	6.35	.250
19127-0047	BB-8491-06T	14-16	2.00-1.30	4.32	.170	6.35	.250
19127-0049	BB-8491-08T	14-16	2.00-1.30	4.32	.170	6.35	.250
19127-0051	BB-8491-10T	14-16	2.00-1.30	4.32	.170	6.35	.250
19127-0053	BB-880-06T	14-16	2.00-1.30	4.32	.170	6.35	.250
19127-0055	BB-880-08T	14-16	2.00-1.30	4.32	.170	6.35	.250
19127-0057	BB-880-10T	14-16	2.00-1.30	4.32	.170	6.35	.250
19127-0059	BB-883-06T	14-16	2.00-1.30	4.32	.170	6.35	.250
19127-0061	BB-883-08T	14-16	2.00-1.30	4.32	.170	6.35	.250
19127-0064	BB-883-10T	14-16	2.00-1.30	4.32	.170	6.35	.250
19127-0066	BB-886-04T	14-16	2.00-1.30	4.32	.170	6.35	.250
19127-0069	BB-886-06T	14-16	2.00-1.30	4.32	.170	6.35	.250
19127-0072	BB-886-08T	14-16	2.00-1.30	4.32	.170	6.35	.250
19131-0008	BB-287-06XT	14-16	2.00-1.30	4.45	.175	5.95	.234
19131-0012	BB-2781-10XT	14-16	2.00-1.30	4.45	.175	5.95	.234
19131-0016	BB-2781-08XT	14-16	2.00-1.30	4.45	.175	5.95	.234
19131-0019	BB-2781-06XT	14-16	2.00-1.30	4.45	.175	5.95	.234
19131-0022	BB-2471-06XT	14-16	2.00-1.30	4.45	.175	5.95	.234
19131-0024	BB-2471-04XT	14-16	2.00-1.30	4.45	.175	5.95	.234
19131-0053	BB-284-06XT	14-16	2.00-1.30	4.45	.175	5.95	.234
19131-0054	BB-284-08XT	14-16	2.00-1.30	4.45	.175	5.95	.234
19131-0055	BB-284-10XT	14-16	2.00-1.30	4.45	.175	5.95	.234
19131-0056	BB-287-04XT	14-16	2.00-1.30	4.45	.175	5.95	.234

Terminal No.	Terminal Eng. No.	Wire Size		Insulation Diameter Max.		Strip Length	
		AWG	mm ²	mm	In.	mm	In.
19131-0057	BB-287-08XT	14-16	2.00-1.30	4.45	.175	5.95	.234
19139-0040	BB-8471-06T	14-16	2.00-1.30	4.32	.170	6.35	.250
19139-0043	BB-8781-06T	14-16	2.00-1.30	4.32	.170	6.35	.250
19139-0046	BB-881-06T	14-16	2.00-1.30	4.32	.170	6.35	.250
19139-0047	BB-881-08T	14-16	2.00-1.30	4.32	.170	6.35	.250
19139-0048	BB-881-10T	14-16	2.00-1.30	4.32	.170	6.35	.250
19139-0049	BB-884-06T	14-16	2.00-1.30	4.32	.170	6.35	.250
19139-0050	BB-884-08T	14-16	2.00-1.30	4.32	.170	6.35	.250
19139-0051	BB-884-10T	14-16	2.00-1.30	4.32	.170	6.35	.250
19139-0052	BB-887-04T	14-16	2.00-1.30	4.32	.170	6.35	.250
19139-0054	BB-887-06T	14-16	2.00-1.30	4.32	.170	6.35	.250
19139-0056	BB-887-08T	14-16	2.00-1.30	4.32	.170	6.35	.250
19144-0014	BB-207-04XT	14-16	2.00-1.30	4.45	.175	5.95	.234
19144-0016	BB-207-06XT	14-16	2.00-1.30	4.45	.175	5.95	.234
19144-0019	BB-224-06XT	14-16	2.00-1.30	4.45	.175	5.95	.234
19144-0021	BB-224-08XT	14-16	2.00-1.30	4.45	.175	5.95	.234
19144-0023	BB-227-06XT	14-16	2.00-1.30	4.45	.175	5.95	.234
19144-0025	BB-227-08XT	14-16	2.00-1.30	4.45	.175	5.95	.234
19144-0027	BB-227-10XT	14-16	2.00-1.30	4.45	.175	5.95	.234
19144-0031	BB-281-06XT	14-16	2.00-1.30	4.45	.175	5.95	.234
19144-0032	BB-281-08XT	14-16	2.00-1.30	4.45	.175	5.95	.234
19144-0033	BB-281-10XT	14-16	2.00-1.30	4.45	.175	5.95	.234
19144-0063	BB-224-04XT	14-16	2.00-1.30	4.45	.175	5.95	.234
19145-0041	BB-607-04XT	14-16	2.00-1.30	4.45	.175	5.95	.234
19145-0043	BB-607-06XT	14-16	2.00-1.30	4.45	.175	5.95	.234
19145-0045	BB-624-04XT	14-16	2.00-1.30	4.45	.175	5.95	.234
19145-0047	BB-624-06XT	14-16	2.00-1.30	4.45	.175	5.95	.234
19145-0049	BB-624-08XT	14-16	2.00-1.30	4.45	.175	5.95	.234
19145-0051	BB-627-06XT	14-16	2.00-1.30	4.45	.175	5.95	.234
19145-0053	BB-627-08XT	14-16	2.00-1.30	4.45	.175	5.95	.234
19145-0055	BB-627-10XT	14-16	2.00-1.30	4.45	.175	5.95	.234
19145-0057	BB-681-06XT	14-16	2.00-1.30	4.45	.175	5.95	.234
19145-0059	BB-681-08XT	14-16	2.00-1.30	4.45	.175	5.95	.234
19145-0061	BB-681-10XT	14-16	2.00-1.30	4.45	.175	5.95	.234
19145-0063	BB-684-06XT	14-16	2.00-1.30	4.45	.175	5.95	.234
19145-0065	BB-684-08XT	14-16	2.00-1.30	4.45	.175	5.95	.234
19145-0067	BB-684-10XT	14-16	2.00-1.30	4.45	.175	5.95	.234
19145-0069	BB-687-04XT	14-16	2.00-1.30	4.45	.175	5.95	.234
19145-0071	BB-687-06XT	14-16	2.00-1.30	4.45	.175	5.95	.234
19145-0073	BB-687-08XT	14-16	2.00-1.30	4.45	.175	5.95	.234
19179-0009	BB-219-06XT	14-16	2.00-1.30	4.45	.175	5.95	.234
19179-0011	BB-219-08XT	14-16	2.00-1.30	4.45	.175	5.95	.234
19179-0013	BB-219-10XT	14-16	2.00-1.30	4.45	.175	5.95	.234
19182-0008	BB-619-06XT	14-16	2.00-1.30	4.45	.175	5.95	.234
19182-0010	BB-619-08XT	14-16	2.00-1.30	4.45	.175	5.95	.234
19182-0012	BB-619-10XT	14-16	2.00-1.30	4.45	.175	5.95	.234
19183-0008	BB-819-06T	14-16	2.00-1.30	4.32	.170	6.35	.250
19183-0010	BB-819-08T	14-16	2.00-1.30	4.32	.170	6.35	.250
19183-0012	BB-819-10T	14-16	2.00-1.30	4.32	.170	6.35	.250
19198-0011	BB-807-04T	14-16	2.00-1.30	4.32	.170	6.35	.250
19198-0013	BB-807-06T	14-16	2.00-1.30	4.32	.170	6.35	.250
19198-0015	BB-824-04T	14-16	2.00-1.30	4.32	.170	6.35	.250
19198-0018	BB-824-06T	14-16	2.00-1.30	4.32	.170	6.35	.250
19198-0020	BB-824-08T	14-16	2.00-1.30	4.32	.170	6.35	.250
19198-0022	BB-827-06T	14-16	2.00-1.30	4.32	.170	6.35	.250
19198-0024	BB-827-08T	14-16	2.00-1.30	4.32	.170	6.35	.250
19198-0026	BB-827-10T	14-16	2.00-1.30	4.32	.170	6.35	.250
19212-0006	WP-2614XT	14-16	2.00-1.30	4.45	.175	5.95	.234
19213-0006	WP-5614T	14-16	2.00-1.30	4.32	.170	4.76	.187
19213-0012	WP-8614T	14-16	2.00-1.30	4.32	.170	6.35	.250

DEFINITION OF TERMS

The following illustrations are a generic terminal representation and not an exact image of any terminal listed in the scope.

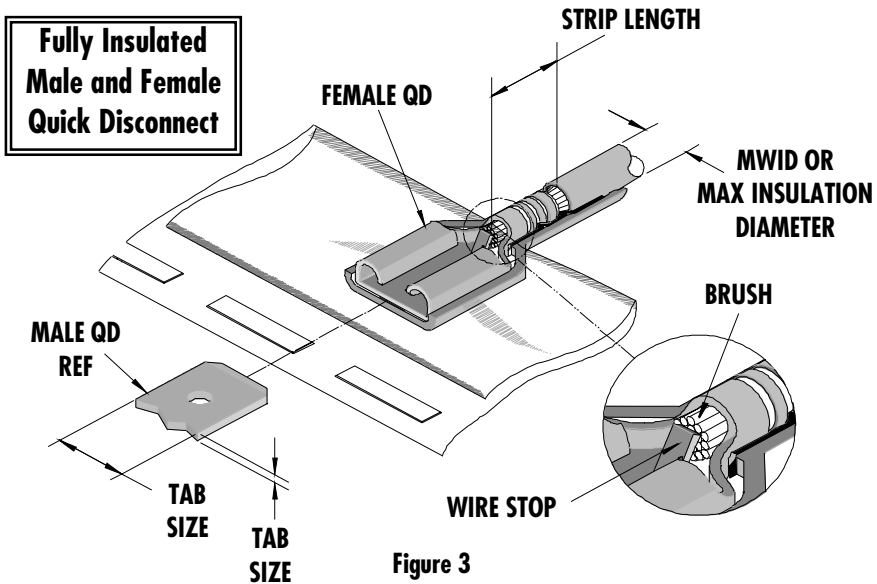
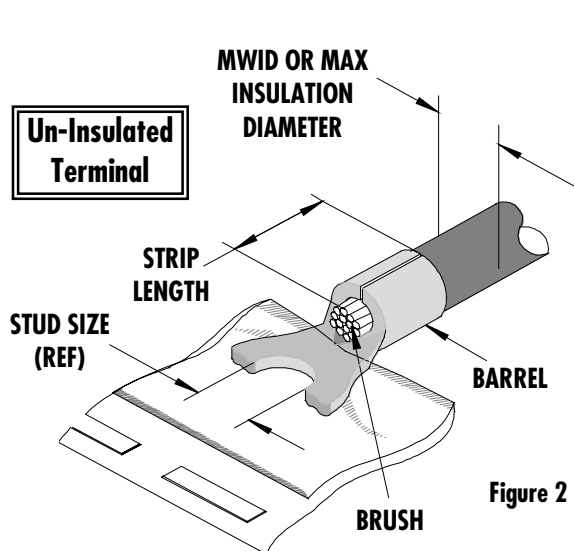
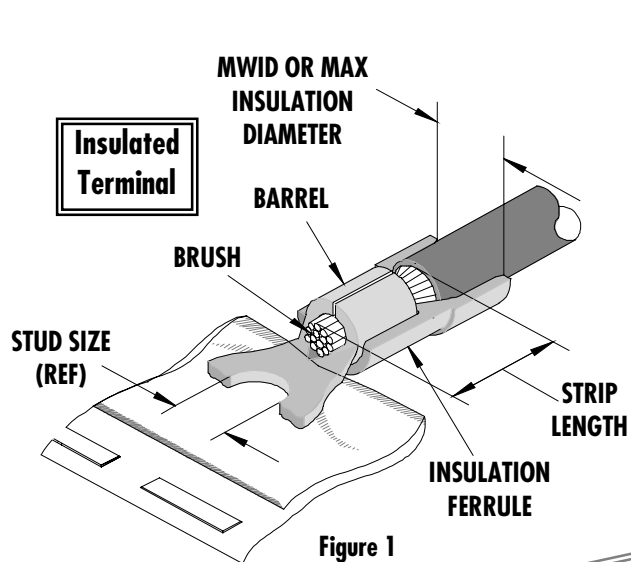

Tool Calibration

To recalibrate this applicator, make sure the power is completely shut off on the press.

1. The Mini-Mac applicator must be properly installed in the press.
2. Crimping dies must be properly installed in the Mini-Mac applicator.
3. The recommended method of measuring the crimp height of the conductor dies is the soft metal slug method, (See Figure 4).
4. The slug must have a diameter 0.51mm (.020") larger than the "X" No Go dimension before crimping.
5. Place the soft metal slug (solder) into the nest of the bottom die and crimp (by hand cycling the press) similar to a terminal. The crimp height can be measured with a blade type micrometer or dial caliper, (Dimension "X").
6. Adjustment of the crimp height can be accomplished by indexing the conductor cam. The letter "A" gives the loosest position and "K" gives the tightest position. A total adjustment of 0.50mm (.020") can be achieved by adjusting the conductor cam.

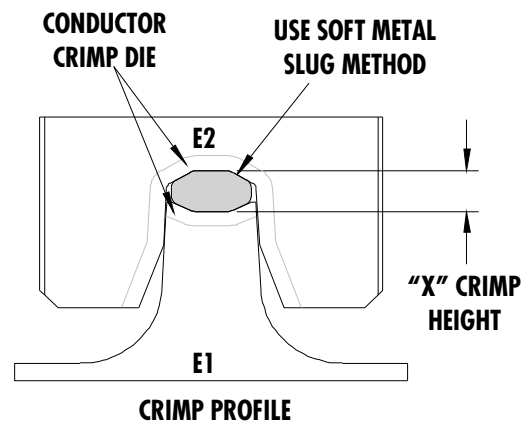

Use soft metal slug (solder) method to measure the "X" dimension. Verify tooling crimp height calibration by referring to the Go/No Go dimensions shown in the chart below.

Figure 4

Note: If the crimp height is too tight on the setting "A", check the shut height of the press. See the Industrial Mini-Mac Applicator Manual Section 2.1 for adjustments.

CRIMP SPECIFICATIONS

Wire Size		"X" Dimension Conductor Crimp						Pull Force Min.	
AWG	mm ²	Mean		Go		No Go		Lbs	N
		In	mm	In	mm	In	mm		
16	1.30	.122	3.10	.119	3.02	.129	3.27	30.0	133.5
14	2.00	.122	3.10	.119	3.02	.129	3.27	50.0	222.6

Pull Force should be measured with no influence from the insulation crimp. The above specifications are guidelines to an optimum crimp.

PARTS LIST

Mini-Mac Applicator 63885-0400				
Item	Order No	Engineering No.	Description	Quantity
Perishable Tooling				
	63885-0470	63885-0470	Tool Kit (All "Y" Items)	REF
1	63465-0006	63465-0006	Conductor Punch	1 Y
2	63464-0006	63464-0006	Conductor Anvil	1 Y
3	63463-0003	63463-0003	Insulation Punch	1 Y
4	63462-0004	63462-0004	Insulation Anvil	1 Y
5	63890-0995	63890-0995	Collar-4.0mm Lg.	1 Y
Other Components (Ref. 50050)				
31	63466-0912	63466-0912	Anvil Mount	1
32	63466-0913	63466-0913	Terminal Support	1
33	63443-0021	63443-0021	Lower Tooling Key	1
42	63466-0921	63466-0921	Terminal Stripping Blade	1
51	63600-1290	63600-1290	Washer	1
52	63890-0866	63890-0866	Collar-6.4mm Lg.	1*
53	63890-0867	63890-0867	Collar-7.7mm Lg.	1
Frame				
81	63801-3301	63801-3301	Air Feed Applicator Frame Head	REF
82	63801-3281	63801-3281	Base	REF
83	63801-5850	63801-5850	Track Assembly	REF
84	63801-3390	63801-3390	Air Kit	REF
Hardware				
91	N/A	N/A	M3 by 12 Lg SHCS	1**
92	N/A	N/A	M4 by 10 Lg SHCS	2**
93	N/A	N/A	M4 by 16 Lg. SHCS	1**
94	N/A	N/A	M4 by 45 Lg. SHCS	1**
95	N/A	N/A	M8 by 30 Lg. BHCS	1**
96	N/A	N/A	3mm by 6 Lg. Roll Pin	1**
** Available from an industrial supply company such as MSC (1-800-645-7270).				

* Not used on 63885-0400 but required for installation of other perishable tooling.

Note: Crimp profiles used in 63885-0400 are equivalent to 19032-0105/MMT-BB-520, 19032-0149/MMT-BB-520, 19288-0123/ATP-BB-520, and 19288-0124/ATP-BB-520-CC (UL file number E32244).

Assembly Drawing

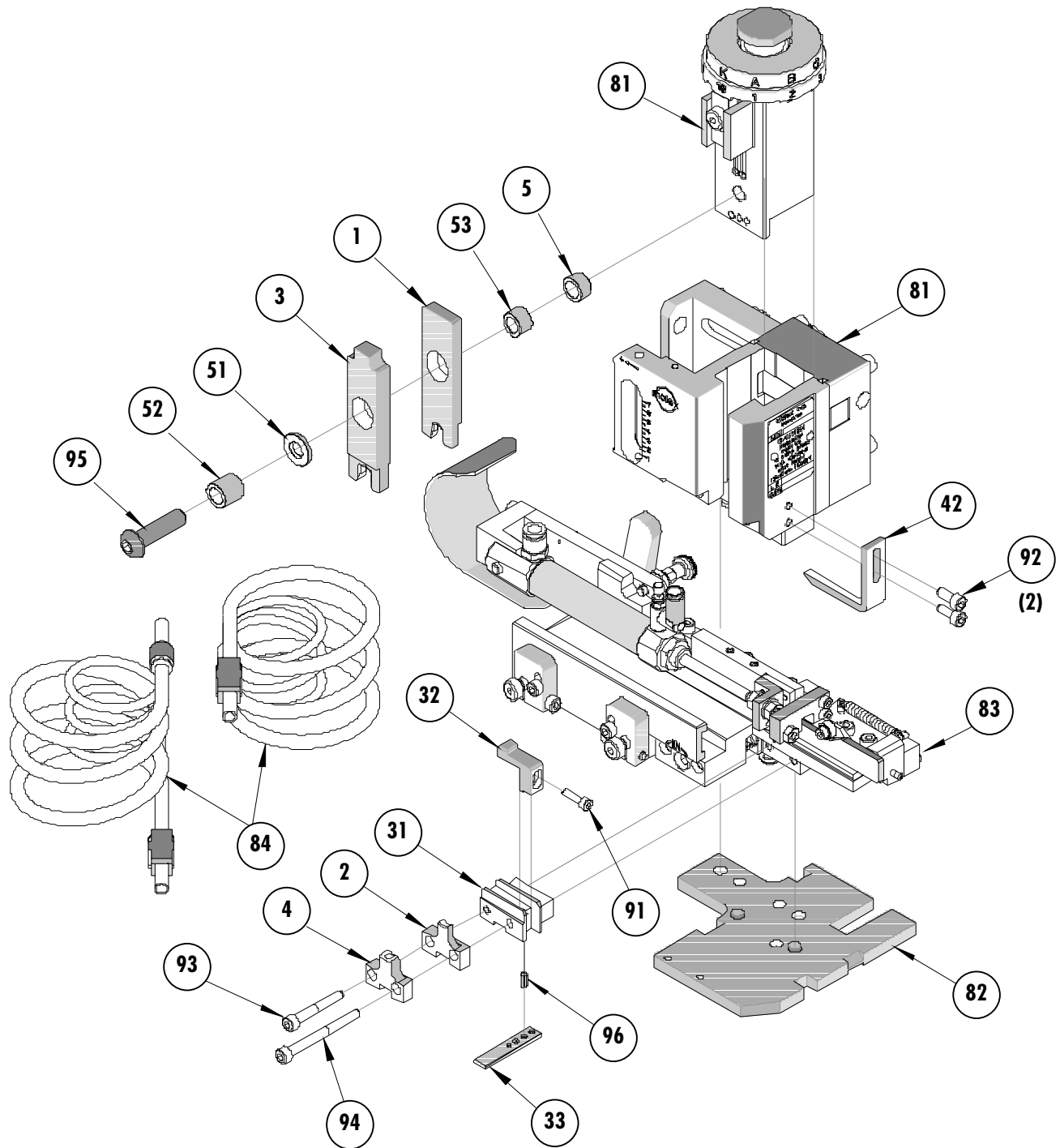

Figure 5

NOTES

1. Molex recommends an extra perishable tooling kit be maintained at your facility.
2. Verify tooling alignment by manually cycling the press with applicator before crimping under power. Check that all screws are tight.
3. Slugs, terminals, dirt, and oil should be kept clear of work area.
4. Wear safety glasses at all times.
5. For recommended maintenance refer to the Mini-Mac Applicator Manual (Document no. 63880-0000).

CAUTION: This applicator should only be used in a press with a shut height of 135.80 mm (5.346"). Tooling damage could result at a lower setting.

CAUTION: To prevent injury, never operate this applicator without the guards supplied with the press or wire-processing machine in place. Reference the press or wire processing manufacturer's instruction manual.

CAUTION: Molex crimp specifications are valid only when used with Molex terminals, applicators and tooling.

Contact Information

For more information on Molex application tooling please contact Molex at 1-800-786-6539.

Molex Application Tooling Group

1150 E. Diehl Road
Naperville, IL 60563
Tel: (630) 969-4550
Fax: (630) 505-0049

Visit our Web site at <http://www.molex.com>