

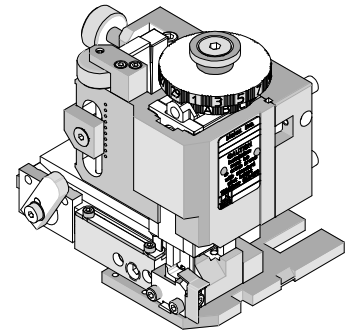

FineAdjust Applicator Specification Sheet Order No. 63865-5100



FEATURES

- Directly adapts to most automatic wire processing machines
- Quick punch removal with the push of a button for fast and easy tooling change
- Applicator designed to industry standard mounting and shut height 135.80mm (5.346")
- Quick set-up time; plus the crimp height, track and feed adjustments can be set without removing the applicator from the press
- Fine adjustment allows users to achieve target with little effort by adjusting in increments of .015mm (.0006") for conductor crimp height and .063mm (.0025") for insulation height
- Independent adjustment rings allow users to quickly adjust the conductor or insulation crimp height without affecting each other

SCOPE

Products: CRC™ (Compact Robot Connector) Shielded Rectangular I/O Crimp pins and sockets, 24-28 AWG.

Terminal Series No.	Terminal Order No.			Wire Size		Insulation Diameter Maximum		Strip Length	
				AWG	mm ²	mm	In.	mm	In.
56116	56116-8090	56116-8099	56116-8228	24-28	0.22-0.08	1.60	.063	2.70-3.20	.106-.126
	56116-8290	56116-8299							
56118	56118-8090	56118-8099	56118-8228	24-28	0.22-0.08	1.60	.063	2.70-3.20	.106-.126
	56118-8290	56118-8299							
56120	56120-8090	56120-8099	56120-8228	24-28	0.22-0.08	1.60	.063	2.70-3.20	.106-.126
	56120-8290	56120-8299	56120-8428						
	56120-8490	56120-8499	56120-8628						
	56120-8699	56120-8690							

DEFINITION OF TERMS

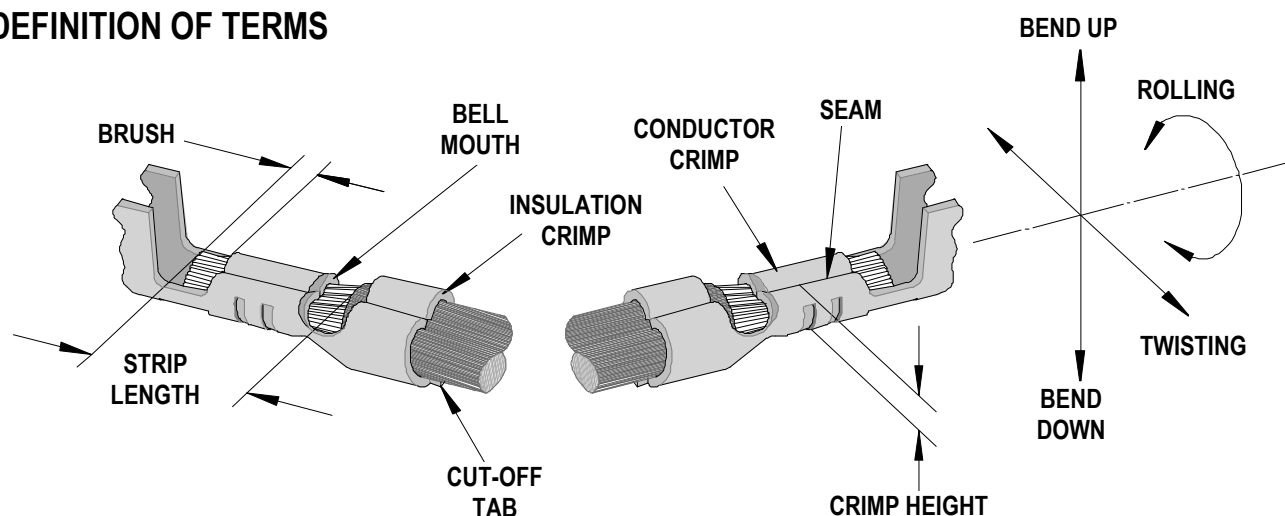

The above terminal drawing is a generic terminal representation. It is not an image of a terminal listed in the scope.

NOTES

1. Molex recommends an extra perishable tooling kit be maintained at your facility.
2. Verify tooling alignment by manually cycling the press and Applicator before crimping under power. Check that all screws are tight.
3. Slugs, Terminals, Dirt and Oil should be kept clear of work area.
4. Wear safety glasses at all times.
5. For recommended maintenance refer to the FineAdjust Manual.

CAUTION: This applicator should only be used in a press with a shut height of 135.8mm (5.346"). Tooling damage could result at a lower setting.

CAUTION: To prevent injury never operate this Applicator without the guards supplied with the press or wire-processing machine in place. Reference the press or wire processing manufacturer's instruction manual.

CAUTION: Molex crimp specifications are valid only when used with Molex terminals, applicators and tooling.

Americas Headquarters
Lisle, Illinois 60532 U.S.A.
1-800-78MOLEX
amerinfo@molex.com

Far East North Headquarters
Yamato, Kanagawa, Japan
81-462-65-2324
feninfo@molex.com

Far East South Headquarters
Jurong, Singapore
65-6-268-6868
fesinfo@molex.com

European Headquarters
Munich, Germany
49-89-413092-0
eurinfo@molex.com

Corporate Headquarters
2222 Wellington Ct.
Lisle, IL 60532 U.S.A.
630-969-4550
Fax: 630-969-1352

Visit our Web site at <http://www.molex.com>