

883031A09M010

no poles 3-5 pole
 cable type #22/3-5 PVC YELLOW
 cable length 010----1 Meter 100----10 Meters

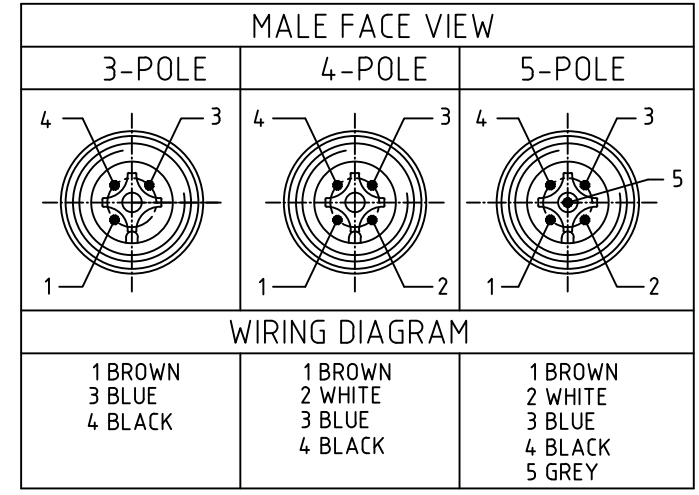

CONNECTOR SPECIFICATION:

VOLTAGE RATING	250 VAC/VDC
AMPERAGE RATING	max. 4 AMPS
PROTECTION	IP67
OPERATING TEMPERATURE	-20°C TO 105°C
UL CERTIFICATIONS	UL RECOGNIZED, FILE NO. E152210
ASSEMBLY IS	RoHS COMPLIANT

MATERIAL NUMBER	ENGINEERING NUMBER	FINISHED LENGTH
1200661137	883031A09M010	1.0M +55.6 -0 [3.28' +2.19" -0]
1200661389	885031A09M010	1.0M +55.6 -0 [3.28' +2.19" -0]
1200661262	884031A09M010	1.0M +55.6 -0 [3.28' +2.19" -0]
1200661280	884031A09M100	10.0M +55.6 -0 [32.8' +2.19" -0]

COMPONENT	MATERIAL	FINISH
LABEL	MYLAR	BLACK/YELLOW
COUPLER	BRASS	NICKEL PLATED
PIN CONTACT	COPPER ALLOY	GOLD OVER NICKEL
INSERT	NYLON	BLACK
OVERMOLD	PUR	YELLOW
CABLE- 22/3-5 (COPPER STRANDING) 3/4/5 CONDUCT. 300V	JACKET: PVC	JACKET: YELLOW

UPDATED FOR PART MATRIX EC NO.: IPG2014-0988 DRWN: GGUSTAFS 11/26/13 CHKD: TWOLDEGE APPR: BWOODMAN 2010/01/29	QUALITY SYMBOLS 	GENERAL TOLERANCES (UNLESS SPECIFIED)		DIMENSION STYLE IN/MM	SCALE NTS	DESIGN UNITS INCH	THIRD ANGLE PROJECTION
		4 PLACES ±--- ±--- 3 PLACES ±--- ±.005 2 PLACES ±.13 ±.010 1 PLACE ±.25 ±.020	mm INCH DRAWN BY DATE LSTEMMLE 2010/01/25 CHECKED BY DATE RE 2010/01/26 APPROVED BY DATE NSTAUDIG 2010/01/29	MICRO-CHANGE CORDSET 3/4/5 POLE FE 90 /MA STR 22/AWG YELLOW PVC CABLE			
		ANGULAR ± .5 ° DRAFT WHERE APPLICABLE MUST REMAIN WITHIN DIMENSIONS	MATERIAL NO. SEE CHART				MOLEX INCORPORATED
		A	SIZE A3	THIS DRAWING CONTAINS INFORMATION THAT IS PROPRIETARY TO MOLEX INCORPORATED AND SHOULD NOT BE USED WITHOUT WRITTEN PERMISSION			DOCUMENT NO. SD-120066-013