

MATERIALS AND FINISHES:

BODY FRONT, CAP, JAM NUT: BRASS  
PLATED: NICKEL (100μ-in MIN)

BODY REAR: BRASS  
PLATED: TIN (150μ-in MIN)

CONTACT: BRASS  
PLATED: GOLD (10μ-in MIN)

INSULATOR: TEFLON

GASKET: SILICONE RUBBER

LOCK WASHER: PHOSPHOR BRONZE  
PLATED: NICKEL (10μ-in MIN)

ELECTRICAL PERFORMANCE:

1.30 VSWR MAX THROUGH 6 GHz  
0.25 dB MAX INSERTION LOSS THRU 6 GHz

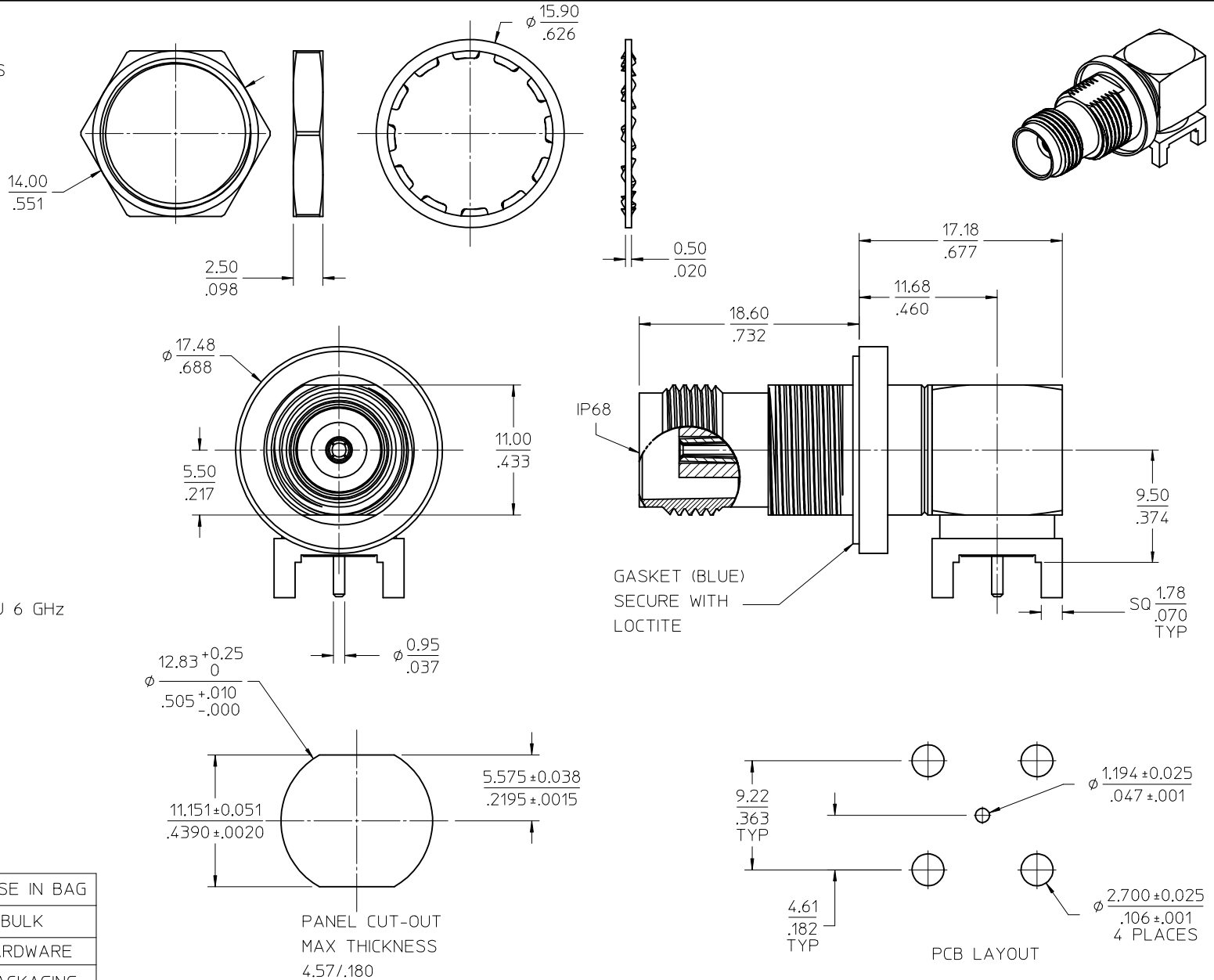

73216-2241	ONE PER BAG	LOOSE IN BAG
73216-2240	BULK	BULK
PART NO.	PACKAGING	HARDWARE
		PACKAGING

CHG: ADDED 9.50 MM DIM IN F1 ZONE. ADD PLATING THICKNESSES EC NO: URF2016-0083 DRW:BBHARADWAJ.D 2015/08/20 CHKD:LLM 2015/08/20 APPR:AROBERTSON 2015/08/28	QUALITY SYMBOLS ▽=0 ▽=0	GENERAL TOLERANCES (UNLESS SPECIFIED) mm INCH 4 PLACES ± --- ± --- 3 PLACES ± --- ± --- 2 PLACES ± --- ± --- 1 PLACE ± --- ± --- ANGULAR ± 2°	DIMENSION STYLE MM/IN DRAWN BY DATE AZR 2009/07/23 CHECKED BY DATE SSS 2009/07/23 APPROVED BY DATE JWIENER 2010/04/22	SCALE DESIGN UNITS METRIC THIRD ANGLE PROJECTION	TITLE TNC JACK RA BULKHEAD IP68 PCB TH TNC-J/PCB, EWR-4151	MATERIAL NO. SEE TABLE	DOCUMENT NO. SD-73216-224	SHEET NO. 1 OF 1	
		DRAFT WHERE APPLICABLE MUST REMAIN WITHIN DIMENSIONS		MOLEX INCORPORATED		MOLEX INCORPORATED		THIS DRAWING CONTAINS INFORMATION THAT IS PROPRIETARY TO MOLEX INCORPORATED AND SHOULD NOT BE USED WITHOUT WRITTEN PERMISSION	