

- NOTES:
- MATERIAL:
    - CONNECTOR:
      - HOUSING - HIGH TEMPERATURE THERMOPLASTIC GLASS FILLED, UL 94V-0, BLACK
      - TERMINALS - COPPER ALLOY
    - SHELL
      - NICKEL SILVER, C770, THICKNESS: 0.250/0.254
  - FINISH:
    - CONNECTOR
      - OPTION 1
        - CONTACT AREA - 0.38μm MIN GOLD OVER 2.54 μm NICKEL
        - SOLDER FOOT AREA - 2.54-5.09μm TIN OVER 1.27 μm NICKEL
      - OPTION 2
        - CONTACT AREA - 0.76μm MIN GOLD OVER 2.54 μm NICKEL
        - SOLDER FOOT AREA - 2.54-5.09μm TIN OVER 1.27 μm NICKEL
  - TERMINAL SOLDER FEET TO BE COPLANAR WITHIN 0.10 MEASURED FROM DATUM E
  - DATE CODE: 4 DIGIT (3 DIGIT DAY, 1 DIGIT YEAR) ON CONNECTOR ONLY
  - CIRCUIT IDENTIFIER: SEE APPROPRIATE INDUSTRY SPECIFICATION FOR LOCATION OF PIN 1
  - TO BE USED WITH THE FOLLOWING CABLE SERIES:
    - 79575/74563/79576/74573/79536/74562/74569/74586
  - PACKAGED PER PACKAGING SPECIFICATION: PK-75783-001
  - CONFORMS TO PRODUCT SPECIFICATION: PS-75783-001
  - PROCESS PER APPLICATION SPECIFICATION: AS-75783-001
  - THIS PART CONFORMS TO CLASS C REQUIREMENTS OF COSMETIC SPEC PS-45499-002

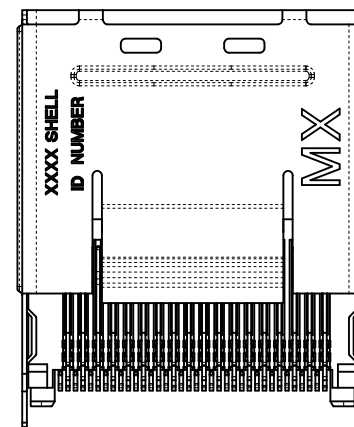
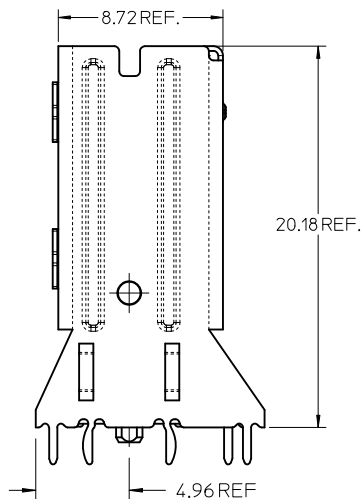
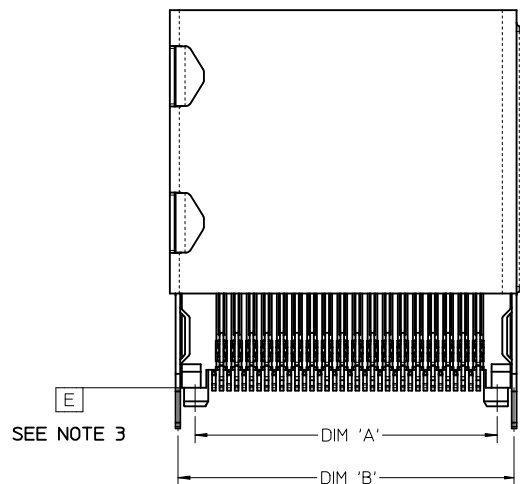

36 CIRCUIT  
RETENTION FIT  
SHELL OPTION SHOWN

iPass™ IS A TRADEMARK OF MOLEX

CIRCUIT SIZE	DIM 'A'	DIM 'B'	DIM 'C'
26	12.00	13.80	11.80
36	16.00	17.80	15.80
50	21.60	23.40	21.40
68	28.80	30.60	28.60

REV	DESCRIPTION	DATE
D4	S1-SMT VIEW ADDED EC NO: UCP2012-2460 DRAWN: DRWINKLANG CHKD: CHKKD: APPR: MBANAKIS	2012/02/03 2012/02/07

QUALITY SYMBOLS
▽=0
▽=0

GENERAL TOLERANCES (UNLESS SPECIFIED)	
mm	INCH
4 PLACES ± ---	± ---
3 PLACES ± ---	± ---
2 PLACES ± 0.13	± ---
1 PLACE ± 0.25	± ---
ANGULAR ± 1/2°	

DRAFT WHERE APPLICABLE  
MUST REMAIN  
WITHIN DIMENSIONS

DIMENSION STYLE MM ONLY	
DRAWN BY	DATE
KLANG	02/09/05
CHECKED BY	DATE
JSWENSON	02/09/05
APPROVED BY	DATE
MBANAKIS	02/02/05
MATERIAL NO.	
SEE CHART	
SIZE	C

SCALE	DESIGN UNITS	THIRD ANGLE PROJECTION
5:1	METRIC	☉
TITLE		
I-PASS VERT CONNECTOR INTERNAL ASSY W/SHELL 0.8MM PITCH I/O		
MOLEX MOLEX INCORPORATED		
DOCUMENT NO.	SHEET NO.	
SD-75784-001	1 OF 12	

THIS DRAWING CONTAINS INFORMATION THAT IS PROPRIETARY TO MOLEX INCORPORATED AND SHOULD NOT BE USED WITHOUT WRITTEN PERMISSION

# ASSEMBLY WITH PRE-POSITIONING DEVICE

PICK & PLACE NOZZLE AREA

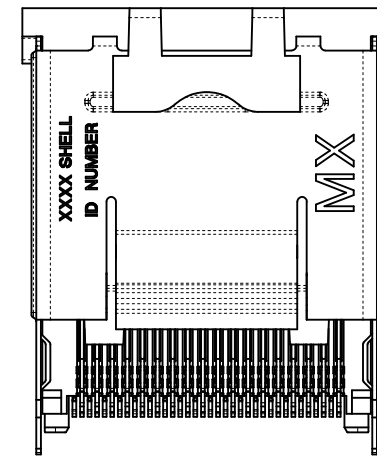
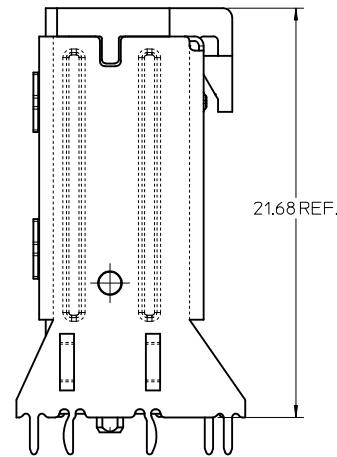
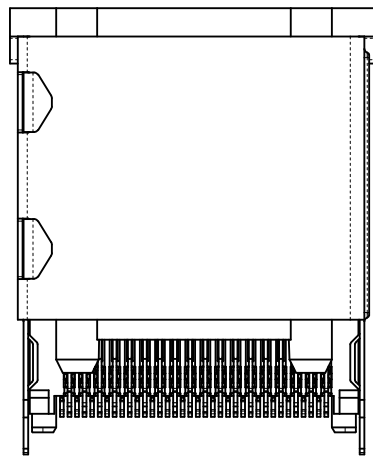
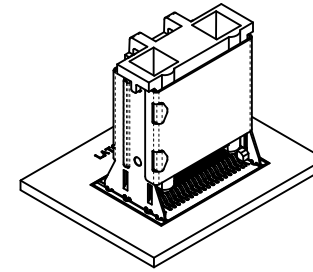
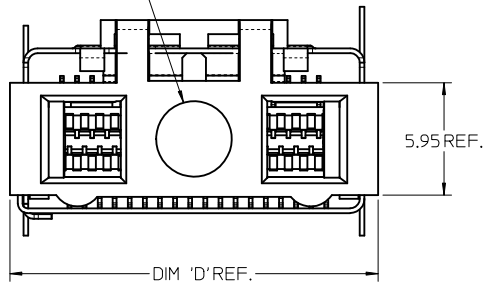

36 CIRCUIT RETENTION FIT SHOWN

NOTES:

- PICK AND PLACE LOCATION DEFINED ON APPLICATION SPECIFICATION AS-75783-001
- PACKAGING CONSISTS OF CONNECTOR AND SHELL WITH A PRE-POSITIONING PICK AND PLACE DEVICE THAT ARE PACKAGED IN 'TAPE AND REEL' FOR ROBOTIC PICK AND PLACE.

iPass™ IS A TRADEMARK OF MOLEX

CIRCUIT SIZE	DIM 'D'
26	15.50
36	19.50
50	25.10
68	32.30

SEE SHEET 1 EC NO: UCP2012-2460 DRW/KLANG 2012/02/03 CHKD: MBANAK IS APPR: MBANAK IS 2012/02/07	QUALITY SYMBOLS ▽=0 ▽=0	GENERAL TOLERANCES (UNLESS SPECIFIED)		DIMENSION STYLE <b>MM ONLY</b>		SCALE 5:1	DESIGN UNITS METRIC	THIRD ANGLE PROJECTION			
		4 PLACES ± --- ± ---	3 PLACES ± --- ± ---	2 PLACES ± 0.13 ± ---	1 PLACE ± 0.25 ± ---	DRAWN BY KLANG	DATE 02/09/05	TITLE I-PASS VERT CONNECTOR INTERNAL ASSY W/SHELL 0.8MM PITCH I/O			
		ANGULAR ± 1/2°				CHECKED BY JSWENSON	DATE 02/09/05	MOLEX MOLEX INCORPORATED			
		DRAFT WHERE APPLICABLE MUST REMAIN WITHIN DIMENSIONS				APPROVED BY MBANAK IS	DATE 02/02/05	MATERIAL NO. SEE CHART	DOCUMENT NO. SD-75784-001	SHEET NO. 2 OF 12	

THIS DRAWING CONTAINS INFORMATION THAT IS PROPRIETARY TO MOLEX INCORPORATED AND SHOULD NOT BE USED WITHOUT WRITTEN PERMISSION

# SHELL PCB INTERFACE

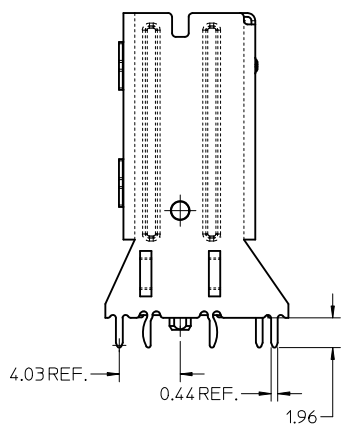
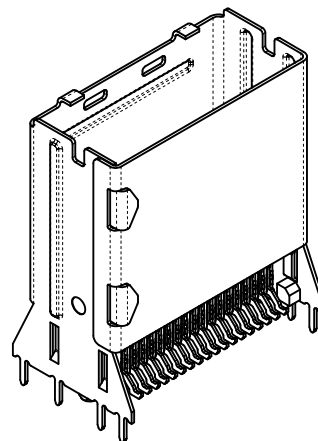
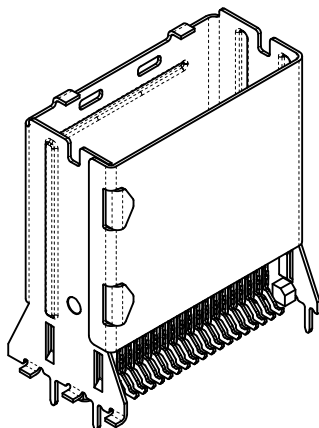
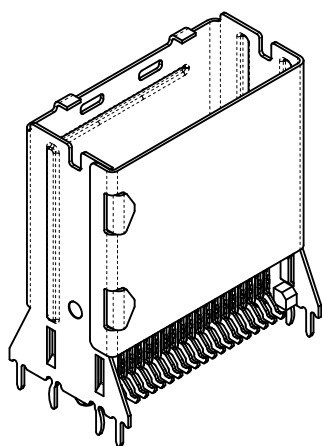

RETENTION-FIT  
SHELL OPTION

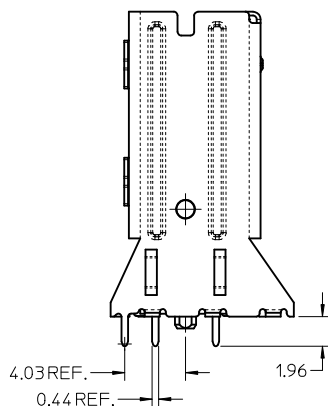

SMT SHELL OPTION

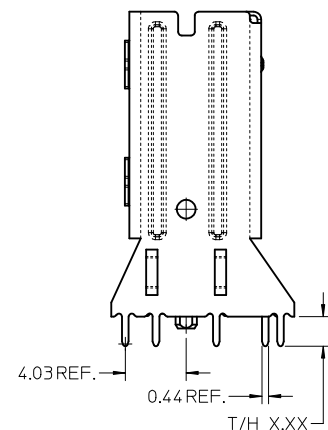

THRU-HOLE SHELL OPTION  
SEE TABLE FOR LENGTH  
(X.XX DENOTES LENGTH)

RECOMMENDED PCB THICKNESS  
FOR SPECIFIED TAIL LENGTH

TAIL LENGTH	PCB THICKNESS
1.96	1.57 (.062)
2.79	2.36 (.093)
3.18	2.79 (.110)
3.56	3.18 (.125)

NOTE:  
RETENTION FIT DENOTES TAILS THAT OFFER RETENTION  
TO PCB DURING REFLOW PROCESS  
SMT DENOTES SURFACE MOUNT TERMINATION  
T/H X.XX DENOTES THRU-HOLE TAIL OF LENGTH X.XX

SEE SHEET 1 EC NO: UCP2012-2460 DRW:KLANG 2012/02/03 CHKD: APPR:MBANAKIS 2012/02/07 DESCRIPTION	QUALITY SYMBOLS	GENERAL TOLERANCES (UNLESS SPECIFIED)	DIMENSION STYLE	SCALE	DESIGN UNITS	THIRD ANGLE PROJECTION
	$\nabla=0$ $\nabla=0$	mm    INCH 4 PLACES ± --- ± --- 3 PLACES ± --- ± --- 2 PLACES ± 0.13 ± --- 1 PLACE ± 0.25 ± --- ANGULAR ± 1/2°	MM ONLY	4:1	METRIC	
		DRAFT WHERE APPLICABLE MUST REMAIN WITHIN DIMENSIONS	DRAWN BY: KLANG CHECKED BY: JSWENSON APPROVED BY: MBANAKIS MATERIAL NO.	DATE: 02/09/05 DATE: 02/09/05 DATE: 02/02/05	TITLE: I-PASS VERT CONNECTOR INTERNAL ASSY W/SHELL 0.8MM PITCH I/O MOLEX INCORPORATED	
	D4		SEE CHART	DOCUMENT NO. SD-75784-001	SHEET NO. 3 OF 12	

THIS DRAWING CONTAINS INFORMATION THAT IS PROPRIETARY TO MOLEX INCORPORATED AND SHOULD NOT BE USED WITHOUT WRITTEN PERMISSION

# KEYING OPTIONS

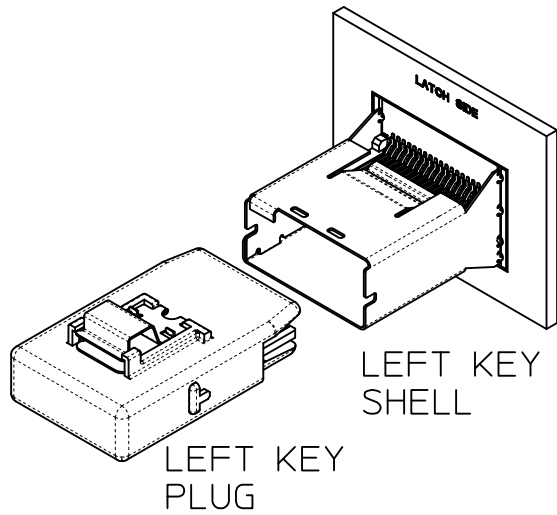

LEFT KEY SHELL

LEFT KEY PLUG

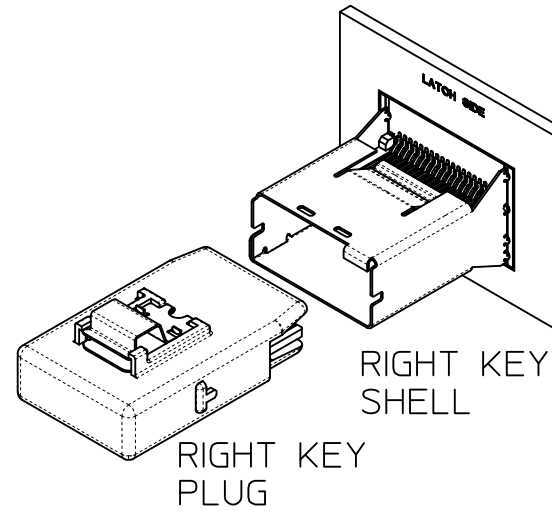

RIGHT KEY SHELL

RIGHT KEY PLUG

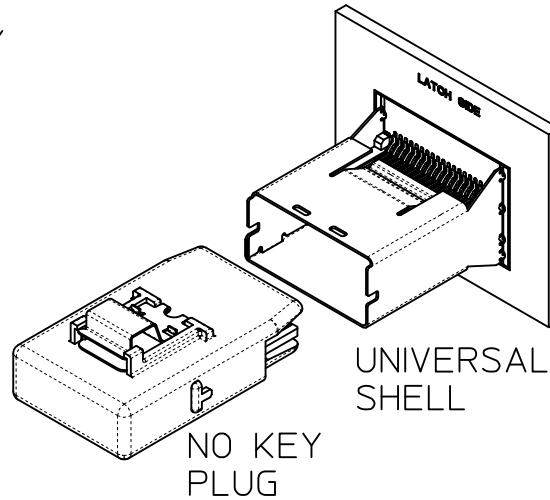

UNIVERSAL SHELL

NO KEY PLUG

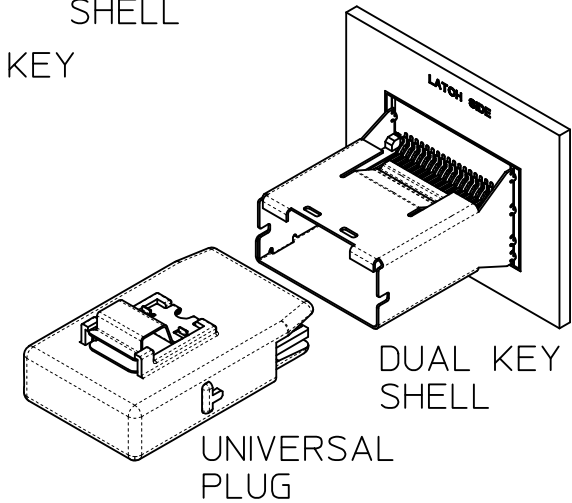

DUAL KEY SHELL

UNIVERSAL PLUG

	UNIVERSAL SHELL	LEFT KEY SHELL	RIGHT KEY SHELL	DUAL KEY SHELL
NO KEY PLUG	YES	NO	NO	NO
LEFT KEY PLUG	YES	YES	NO	NO
RIGHT KEY PLUG	YES	NO	YES	NO
UNIVERSAL PLUG	YES	YES	YES	YES

iPass™ IS A TRADEMARK OF MOLEX

SEE SHEET 1 EC NO: UCP2012-2460 DRINKLANG 2012/02/03 CHKD: APPR: MBANAKIS 2012/02/07	QUALITY SYMBOLS ▽=0 ▽=0	GENERAL TOLERANCES (UNLESS SPECIFIED) <table border="1"> <tr> <th></th> <th>mm</th> <th>INCH</th> </tr> <tr> <td>4 PLACES</td> <td>± .005</td> <td>± .0004</td> </tr> <tr> <td>3 PLACES</td> <td>± .005</td> <td>± .0004</td> </tr> <tr> <td>2 PLACES</td> <td>± 0.13</td> <td>± .005</td> </tr> <tr> <td>1 PLACE</td> <td>± 0.25</td> <td>± .010</td> </tr> </table> ANGULAR ±1/2°		mm	INCH	4 PLACES	± .005	± .0004	3 PLACES	± .005	± .0004	2 PLACES	± 0.13	± .005	1 PLACE	± 0.25	± .010	DIMENSION STYLE <b>MM ONLY</b> DRAWN BY: KLANG DATE: 02/09/05 CHECKED BY: JSWENSON DATE: 02/09/05 APPROVED BY: MBANAKIS DATE: 02/02/05	SCALE: 2:1 DESIGN UNITS: METRIC THIRD ANGLE PROJECTION	TITLE: <b>I-PASS VERT CONNECTOR                  INTERNAL ASSY W/SHELL                  0.8MM PITCH I/O</b>
		mm	INCH																	
	4 PLACES	± .005	± .0004																	
	3 PLACES	± .005	± .0004																	
2 PLACES	± 0.13	± .005																		
1 PLACE	± 0.25	± .010																		
DRAFT WHERE APPLICABLE MUST REMAIN WITHIN DIMENSIONS			MATERIAL NO. <b>SEE CHART</b>	MOLEX INCORPORATED	DOCUMENT NO. <b>SD-75784-001</b>															
			SIZE: C	THIS DRAWING CONTAINS INFORMATION THAT IS PROPRIETARY TO MOLEX INCORPORATED AND SHOULD NOT BE USED WITHOUT WRITTEN PERMISSION																
			SHEET NO. 4 OF 12																	

# 26 CIRCUIT ITEM NUMBERS

CIRCUIT SIZE	ITEM NUMBER	PLATING OPTION	SHELL PCB OPTION	SHELL KEY OPTION
26	75784-0007	OPTION 1	RETENTION	LEFT
26	75784-0008	OPTION 1	RETENTION	RIGHT
26	75784-0009	OPTION 1	RETENTION	DUAL
26	75784-0010	OPTION 1	SMT	LEFT
26	75784-0011	OPTION 1	SMT	RIGHT
26	75784-0012	OPTION 1	SMT	DUAL
26	75784-0019	OPTION 2	RETENTION	LEFT
26	75784-0020	OPTION 2	RETENTION	RIGHT
26	75784-0021	OPTION 2	RETENTION	DUAL
26	75784-0022	OPTION 2	SMT	LEFT
26	75784-0023	OPTION 2	SMT	RIGHT
26	75784-0024	OPTION 2	SMT	DUAL
26	75784-0025	OPTION 1	RETENTION	UNIVERSAL
26	75784-0026	OPTION 1	SMT	UNIVERSAL
26	75784-0027	OPTION 2	RETENTION	UNIVERSAL
26	75784-0028	OPTION 2	SMT	UNIVERSAL
26	75784-0029	OPTION 1	T/H 1.96	LEFT
26	75784-0030	OPTION 1	T/H 1.96	RIGHT
26	75784-0031	OPTION 1	T/H 1.96	DUAL
26	75784-0032	OPTION 1	T/H 1.96	UNIVERSAL
26	75784-0033	OPTION 2	T/H 1.96	LEFT
26	75784-0034	OPTION 2	T/H 1.96	RIGHT
26	75784-0035	OPTION 2	T/H 1.96	DUAL
26	75784-0036	OPTION 2	T/H 1.96	UNIVERSAL

CIRCUIT SIZE	ITEM NUMBER	PLATING OPTION	SHELL PCB OPTION	SHELL KEY OPTION
26	75784-0037	OPTION 1	T/H 2.79	LEFT
26	75784-0038	OPTION 1	T/H 2.79	RIGHT
26	75784-0039	OPTION 1	T/H 2.79	DUAL
26	75784-0040	OPTION 1	T/H 2.79	UNIVERSAL
26	75784-0041	OPTION 2	T/H 2.79	LEFT
26	75784-0042	OPTION 2	T/H 2.79	RIGHT
26	75784-0043	OPTION 2	T/H 2.79	DUAL
26	75784-0044	OPTION 2	T/H 2.79	UNIVERSAL
26	75784-0045	OPTION 1	T/H 3.18	LEFT
26	75784-0046	OPTION 1	T/H 3.18	RIGHT
26	75784-0047	OPTION 1	T/H 3.18	DUAL
26	75784-0048	OPTION 1	T/H 3.18	UNIVERSAL
26	75784-0049	OPTION 2	T/H 3.18	LEFT
26	75784-0050	OPTION 2	T/H 3.18	RIGHT
26	75784-0051	OPTION 2	T/H 3.18	DUAL
26	75784-0052	OPTION 2	T/H 3.18	UNIVERSAL

iPass™ IS A TRADEMARK OF MOLEX

SEE SHEET 1 EC NO: UCP2012-2460 DRW:KLANG 2012/02/03 CHKD: APPR:MBANAKIS 2012/02/07	DESCRIPTION REV:	QUALITY SYMBOLS ▽=0 ▽=0	GENERAL TOLERANCES (UNLESS SPECIFIED) <table border="1"> <tr> <th></th> <th>mm</th> <th>INCH</th> </tr> <tr> <td>4 PLACES</td> <td>± .005</td> <td>± .0002</td> </tr> <tr> <td>3 PLACES</td> <td>± .005</td> <td>± .0002</td> </tr> <tr> <td>2 PLACES</td> <td>± 0.13</td> <td>± .005</td> </tr> <tr> <td>1 PLACE</td> <td>± 0.25</td> <td>± .010</td> </tr> </table> ANGULAR ±1/2°		mm	INCH	4 PLACES	± .005	± .0002	3 PLACES	± .005	± .0002	2 PLACES	± 0.13	± .005	1 PLACE	± 0.25	± .010	DIMENSION STYLE <b>MM ONLY</b>	SCALE <b>2:1</b>	DESIGN UNITS <b>METRIC</b>	THIRD ANGLE PROJECTION
			mm	INCH																		
		4 PLACES	± .005	± .0002																		
		3 PLACES	± .005	± .0002																		
2 PLACES	± 0.13	± .005																				
1 PLACE	± 0.25	± .010																				
DRAWN BY KLANG		DATE 02/09/05		TITLE <b>I-PASS VERT CONNECTOR                  INTERNAL ASSY W/SHELL                  0.8MM PITCH I/O</b>																		
CHECKED BY JSWENSON		DATE 02/09/05		MOLEX MOLEX INCORPORATED																		
APPROVED BY MBANAKIS		DATE 02/02/05		MATERIAL NO. <b>SEE CHART</b>		DOCUMENT NO. <b>SD-75784-001</b>																

DRAFT WHERE APPLICABLE  
MUST REMAIN  
WITHIN DIMENSIONS

SEE CHART

THIS DRAWING CONTAINS INFORMATION THAT IS PROPRIETARY TO MOLEX INCORPORATED AND SHOULD NOT BE USED WITHOUT WRITTEN PERMISSION

SHEET NO.  
5 OF 12

# 36 CIRCUIT ITEM NUMBERS

CIRCUIT SIZE	ITEM NUMBER	PLATING OPTION	SHELL PCB OPTION	SHELL KEY OPTION
36	75784-0107	OPTION 1	RETENTION	LEFT
36	75784-0108	OPTION 1	RETENTION	RIGHT
36	75784-0109	OPTION 1	RETENTION	DUAL
36	75784-0110	OPTION 1	SMT	LEFT
36	75784-0111	OPTION 1	SMT	RIGHT
36	75784-0112	OPTION 1	SMT	DUAL
36	75784-0119	OPTION 2	RETENTION	LEFT
36	75784-0120	OPTION 2	RETENTION	RIGHT
36	75784-0121	OPTION 2	RETENTION	DUAL
36	75784-0122	OPTION 2	SMT	LEFT
36	75784-0123	OPTION 2	SMT	RIGHT
36	75784-0124	OPTION 2	SMT	DUAL
36	75784-0125	OPTION 1	RETENTION	UNIVERSAL
36	75784-0126	OPTION 1	SMT	UNIVERSAL
36	75784-0127	OPTION 2	RETENTION	UNIVERSAL
36	75784-0128	OPTION 2	SMT	UNIVERSAL
36	75784-0129	OPTION 1	T/H 1.96	LEFT
36	75784-0130	OPTION 1	T/H 1.96	RIGHT
36	75784-0131	OPTION 1	T/H 1.96	DUAL
36	75784-0132	OPTION 1	T/H 1.96	UNIVERSAL
36	75784-0133	OPTION 2	T/H 1.96	LEFT
36	75784-0134	OPTION 2	T/H 1.96	RIGHT
36	75784-0135	OPTION 2	T/H 1.96	DUAL
36	75784-0136	OPTION 2	T/H 1.96	UNIVERSAL

CIRCUIT SIZE	ITEM NUMBER	PLATING OPTION	SHELL PCB OPTION	SHELL KEY OPTION
36	75784-0137	OPTION 1	T/H 2.79	LEFT
36	75784-0138	OPTION 1	T/H 2.79	RIGHT
36	75784-0139	OPTION 1	T/H 2.79	DUAL
36	75784-0140	OPTION 1	T/H 2.79	UNIVERSAL
36	75784-0141	OPTION 2	T/H 2.79	LEFT
36	75784-0142	OPTION 2	T/H 2.79	RIGHT
36	75784-0143	OPTION 2	T/H 2.79	DUAL
36	75784-0144	OPTION 2	T/H 2.79	UNIVERSAL
36	75784-0145	OPTION 1	T/H 3.18	LEFT
36	75784-0146	OPTION 1	T/H 3.18	RIGHT
36	75784-0147	OPTION 1	T/H 3.18	DUAL
36	75784-0148	OPTION 1	T/H 3.18	UNIVERSAL
36	75784-0149	OPTION 2	T/H 3.18	LEFT
36	75784-0150	OPTION 2	T/H 3.18	RIGHT
36	75784-0151	OPTION 2	T/H 3.18	DUAL
36	75784-0152	OPTION 2	T/H 3.18	UNIVERSAL
36	75784-0153	OPTION 1	T/H 3.56	LEFT
36	75784-0154	OPTION 1	T/H 3.56	RIGHT
36	75784-0155	OPTION 1	T/H 3.56	DUAL
36	75784-0156	OPTION 1	T/H 3.56	UNIVERSAL
36	75784-0157	OPTION 2	T/H 3.56	LEFT
36	75784-0158	OPTION 2	T/H 3.56	RIGHT
36	75784-0159	OPTION 2	T/H 3.56	DUAL
36	75784-0160	OPTION 2	T/H 3.56	UNIVERSAL

iPass™ IS A TRADEMARK OF MOLEX

SEE SHEET 1 EC NO: UCP2012-2460 DRAWN BY: DRWINKLANG CHKD: MBANAKIS APPR: MBANAKIS 2012/02/03 2012/02/07	DESCRIPTION REV: D4	QUALITY SYMBOLS ▽=0 ▽=0	GENERAL TOLERANCES (UNLESS SPECIFIED) <table border="1"> <tr> <th></th> <th>mm</th> <th>INCH</th> </tr> <tr> <td>4 PLACES</td> <td>± .005</td> <td>± .0002</td> </tr> <tr> <td>3 PLACES</td> <td>± .005</td> <td>± .0002</td> </tr> <tr> <td>2 PLACES</td> <td>± 0.13</td> <td>± .005</td> </tr> <tr> <td>1 PLACE</td> <td>± 0.25</td> <td>± .010</td> </tr> </table>		mm	INCH	4 PLACES	± .005	± .0002	3 PLACES	± .005	± .0002	2 PLACES	± 0.13	± .005	1 PLACE	± 0.25	± .010	DIMENSION STYLE <b>MM ONLY</b>	SCALE <b>2:1</b>	DESIGN UNITS <b>METRIC</b>	THIRD ANGLE PROJECTION
			mm	INCH																		
		4 PLACES	± .005	± .0002																		
		3 PLACES	± .005	± .0002																		
2 PLACES	± 0.13	± .005																				
1 PLACE	± 0.25	± .010																				
DRAWN BY: KLANG DATE: 02/09/05			CHECKED BY: JSWENSON DATE: 02/09/05			TITLE <b>I-PASS VERT CONNECTOR                  INTERNAL ASSY W/SHELL                  0.8MM PITCH I/O</b>																
APPROVED BY: MBANAKIS DATE: 02/02/05			MATERIAL NO. <b>SEE CHART</b>					DOCUMENT NO. <b>SD-75784-001</b>														
DRAFT WHERE APPLICABLE MUST REMAIN WITHIN DIMENSIONS			SIZE C			SHEET NO. 6 OF 12																
THIS DRAWING CONTAINS INFORMATION THAT IS PROPRIETARY TO MOLEX INCORPORATED AND SHOULD NOT BE USED WITHOUT WRITTEN PERMISSION																						

# 50 CIRCUIT ITEM NUMBERS

CIRCUIT SIZE	ITEM NUMBER	PLATING OPTION	SHELL PCB OPTION	SHELL KEY OPTION
50	75784-0207	OPTION 1	RETENTION	LEFT
50	75784-0208	OPTION 1	RETENTION	RIGHT
50	75784-0209	OPTION 1	RETENTION	DUAL
50	75784-0210	OPTION 1	SMT	LEFT
50	75784-0211	OPTION 1	SMT	RIGHT
50	75784-0212	OPTION 1	SMT	DUAL
50	75784-0219	OPTION 2	RETENTION	LEFT
50	75784-0220	OPTION 2	RETENTION	RIGHT
50	75784-0221	OPTION 2	RETENTION	DUAL
50	75784-0222	OPTION 2	SMT	LEFT
50	75784-0223	OPTION 2	SMT	RIGHT
50	75784-0224	OPTION 2	SMT	DUAL
50	75784-0225	OPTION 1	RETENTION	UNIVERSAL
50	75784-0226	OPTION 1	SMT	UNIVERSAL
50	75784-0227	OPTION 2	RETENTION	UNIVERSAL
50	75784-0228	OPTION 2	SMT	UNIVERSAL
50	75784-0229	OPTION 1	T/H 1.96	LEFT
50	75784-0230	OPTION 1	T/H 1.96	RIGHT
50	75784-0231	OPTION 1	T/H 1.96	DUAL
50	75784-0232	OPTION 1	T/H 1.96	UNIVERSAL
50	75784-0233	OPTION 2	T/H 1.96	LEFT
50	75784-0234	OPTION 2	T/H 1.96	RIGHT
50	75784-0235	OPTION 2	T/H 1.96	DUAL
50	75784-0236	OPTION 2	T/H 1.96	UNIVERSAL

CIRCUIT SIZE	ITEM NUMBER	PLATING OPTION	SHELL PCB OPTION	SHELL KEY OPTION
50	75784-0237	OPTION 1	T/H 2.79	LEFT
50	75784-0238	OPTION 1	T/H 2.79	RIGHT
50	75784-0239	OPTION 1	T/H 2.79	DUAL
50	75784-0240	OPTION 1	T/H 2.79	UNIVERSAL
50	75784-0241	OPTION 2	T/H 2.79	LEFT
50	75784-0242	OPTION 2	T/H 2.79	RIGHT
50	75784-0243	OPTION 2	T/H 2.79	DUAL
50	75784-0244	OPTION 2	T/H 2.79	UNIVERSAL
50	75784-0245	OPTION 1	T/H 3.18	LEFT
50	75784-0246	OPTION 1	T/H 3.18	RIGHT
50	75784-0247	OPTION 1	T/H 3.18	DUAL
50	75784-0248	OPTION 1	T/H 3.18	UNIVERSAL
50	75784-0249	OPTION 2	T/H 3.18	LEFT
50	75784-0250	OPTION 2	T/H 3.18	RIGHT
50	75784-0251	OPTION 2	T/H 3.18	DUAL
50	75784-0252	OPTION 2	T/H 3.18	UNIVERSAL

iPass™ IS A TRADEMARK OF MOLEX

SEE SHEET 1 EC NO: UCP2012-2460 DRW:KLANG 2012/02/03 CHKD: APPR:MBANAKIS 2012/02/07	DESCRIPTION REV:	QUALITY SYMBOLS ▽=0 ▽=0	GENERAL TOLERANCES (UNLESS SPECIFIED) <table border="1"> <tr> <th></th> <th>mm</th> <th>INCH</th> </tr> <tr> <td>4 PLACES</td> <td>± .005</td> <td>± .0002</td> </tr> <tr> <td>3 PLACES</td> <td>± .005</td> <td>± .0002</td> </tr> <tr> <td>2 PLACES</td> <td>± 0.13</td> <td>± .005</td> </tr> <tr> <td>1 PLACE</td> <td>± 0.25</td> <td>± .010</td> </tr> </table> ANGULAR ±1/2°		mm	INCH	4 PLACES	± .005	± .0002	3 PLACES	± .005	± .0002	2 PLACES	± 0.13	± .005	1 PLACE	± 0.25	± .010	DIMENSION STYLE <b>MM ONLY</b>	SCALE <b>2:1</b>	DESIGN UNITS <b>METRIC</b>	THIRD ANGLE PROJECTION
			mm	INCH																		
		4 PLACES	± .005	± .0002																		
		3 PLACES	± .005	± .0002																		
2 PLACES	± 0.13	± .005																				
1 PLACE	± 0.25	± .010																				
DRAWN BY KLANG		DATE 02/09/05		TITLE <b>I-PASS VERT CONNECTOR                  INTERNAL ASSY W/SHELL                  0.8MM PITCH I/O</b>																		
CHECKED BY JSWENSON		DATE 02/09/05		MOLEX MOLEX INCORPORATED																		
APPROVED BY MBANAKIS		DATE 02/02/05		MATERIAL NO. <b>SEE CHART</b>		DOCUMENT NO. <b>SD-75784-001</b>																

DRAFT WHERE APPLICABLE  
MUST REMAIN  
WITHIN DIMENSIONS

SEE CHART

THIS DRAWING CONTAINS INFORMATION THAT IS PROPRIETARY TO MOLEX INCORPORATED AND SHOULD NOT BE USED WITHOUT WRITTEN PERMISSION

SHEET NO.  
7 OF 12

# 68 CIRCUIT ITEM NUMBERS

CIRCUIT SIZE	ITEM NUMBER	PLATING OPTION	SHELL PCB OPTION	SHELL KEY OPTION
68	75784-0307	OPTION 1	RETENTION	LEFT
68	75784-0308	OPTION 1	RETENTION	RIGHT
68	75784-0309	OPTION 1	RETENTION	DUAL
68	75784-0310	OPTION 1	SMT	LEFT
68	75784-0311	OPTION 1	SMT	RIGHT
68	75784-0312	OPTION 1	SMT	DUAL
68	75784-0319	OPTION 2	RETENTION	LEFT
68	75784-0320	OPTION 2	RETENTION	RIGHT
68	75784-0321	OPTION 2	RETENTION	DUAL
68	75784-0322	OPTION 2	SMT	LEFT
68	75784-0323	OPTION 2	SMT	RIGHT
68	75784-0324	OPTION 2	SMT	DUAL
68	75784-0325	OPTION 1	RETENTION	UNIVERSAL
68	75784-0326	OPTION 1	SMT	UNIVERSAL
68	75784-0327	OPTION 2	RETENTION	UNIVERSAL
68	75784-0328	OPTION 2	SMT	UNIVERSAL
68	75784-0329	OPTION 1	T/H 1.96	LEFT
68	75784-0330	OPTION 1	T/H 1.96	RIGHT
68	75784-0331	OPTION 1	T/H 1.96	DUAL
68	75784-0332	OPTION 1	T/H 1.96	UNIVERSAL
68	75784-0333	OPTION 2	T/H 1.96	LEFT
68	75784-0334	OPTION 2	T/H 1.96	RIGHT
68	75784-0335	OPTION 2	T/H 1.96	DUAL
68	75784-0336	OPTION 2	T/H 1.96	UNIVERSAL

CIRCUIT SIZE	ITEM NUMBER	PLATING OPTION	SHELL PCB OPTION	SHELL KEY OPTION
68	75784-0337	OPTION 1	T/H 2.79	LEFT
68	75784-0338	OPTION 1	T/H 2.79	RIGHT
68	75784-0339	OPTION 1	T/H 2.79	DUAL
68	75784-0340	OPTION 1	T/H 2.79	UNIVERSAL
68	75784-0341	OPTION 2	T/H 2.79	LEFT
68	75784-0342	OPTION 2	T/H 2.79	RIGHT
68	75784-0343	OPTION 2	T/H 2.79	DUAL
68	75784-0344	OPTION 2	T/H 2.79	UNIVERSAL
68	75784-0345	OPTION 1	T/H 3.18	LEFT
68	75784-0346	OPTION 1	T/H 3.18	RIGHT
68	75784-0347	OPTION 1	T/H 3.18	DUAL
68	75784-0348	OPTION 1	T/H 3.18	UNIVERSAL
68	75784-0349	OPTION 2	T/H 3.18	LEFT
68	75784-0350	OPTION 2	T/H 3.18	RIGHT
68	75784-0351	OPTION 2	T/H 3.18	DUAL
68	75784-0352	OPTION 2	T/H 3.18	UNIVERSAL

iPass™ IS A TRADEMARK OF MOLEX

SEE SHEET 1 EC NO: UCP2012-2460 DRW: KLKLANG 2012/02/03 CHKD: MBANAKIS APPR: MBANAKIS 2012/02/07	REV D4	DESCRIPTION QUALITY SYMBOLS ▽=0 ▽=0	GENERAL TOLERANCES (UNLESS SPECIFIED)		DIMENSION STYLE <b>MM ONLY</b>		SCALE <b>2:1</b>	DESIGN UNITS METRIC	THIRD ANGLE PROJECTION			
			DRAWN BY KLANG		DATE 02/09/05		TITLE <b>I-PASS VERT CONNECTOR                  INTERNAL ASSY W/SHELL                  0.8MM PITCH I/O</b>					
			CHECKED BY JSWENSON		DATE 02/09/05							
			APPROVED BY MBANAKIS		DATE 02/02/05		MATERIAL NO. <b>SEE CHART</b>		DOCUMENT NO. <b>SD-75784-001</b>		SHEET NO. 8 OF 12	
DRAFT WHERE APPLICABLE MUST REMAIN WITHIN DIMENSIONS												
THIS DRAWING CONTAINS INFORMATION THAT IS PROPRIETARY TO MOLEX INCORPORATED AND SHOULD NOT BE USED WITHOUT WRITTEN PERMISSION												

# VERTICAL CONNECTOR WITH RETENTION FIT & THRU-HOLE SHELL PCB FOOT PRINT

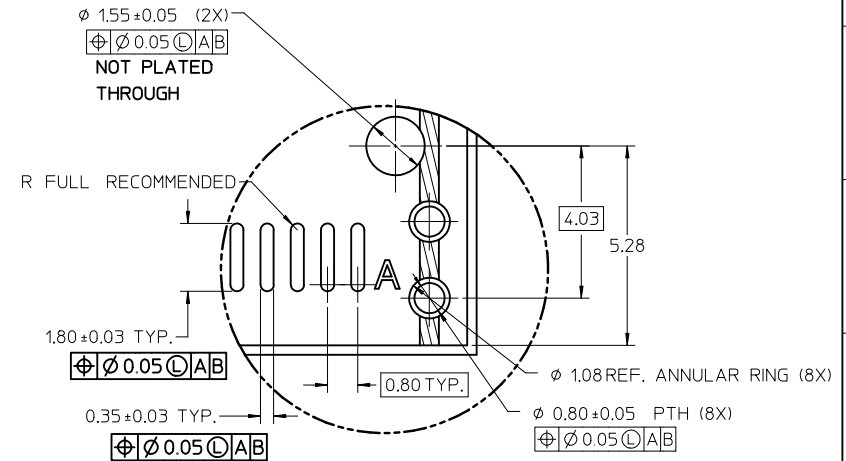
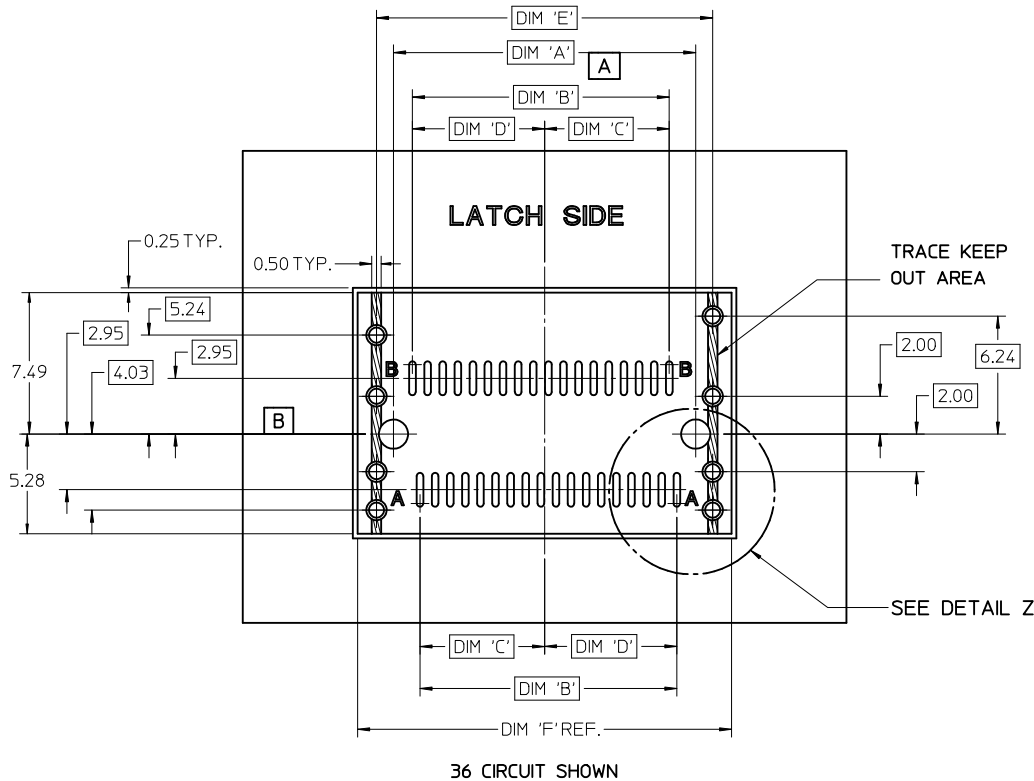

DETAIL Z  
SCALE 10:1

CIRCUIT SIZE	DIMENSIONS					
	DIM 'A'	DIM 'B'	DIM 'C'	DIM 'D'	DIM 'E'	DIM 'F'
26	12.00	9.60	4.60	5.00	13.80	15.80
36	16.00	13.60	6.60	7.00	17.80	19.80
50	21.60	19.20	9.40	9.80	23.40	25.40
68	28.80	26.40	13.00	13.40	30.60	32.60

SEE SHEET 1 EC NO: UCP2012-2460 DRINKLANG 2012/02/03 CHKD: APPR: MBANAKIS 2012/02/07 REV: D4	QUALITY SYMBOLS ▽=0 ▽=0	GENERAL TOLERANCES (UNLESS SPECIFIED)		DIMENSION STYLE <b>MM ONLY</b>		SCALE 5:1	DESIGN UNITS METRIC	THIRD ANGLE PROJECTION	
		4 PLACES ± --- INCH 3 PLACES ± --- INCH 2 PLACES ± 0.13 INCH 1 PLACE ± 0.25 INCH		DRAWN BY KLANG 02/09/05		TITLE <b>I-PASS VERT CONNECTOR INTERNAL ASSY W/SHELL 0.8MM PITCH I/O</b>			
		ANGULAR ±1/2°		CHECKED BY JSWENSON 02/09/05		MOLEX INCORPORATED			
		DRAFT WHERE APPLICABLE MUST REMAIN WITHIN DIMENSIONS		APPROVED BY MBANAKIS 02/02/05		MATERIAL NO. <b>SEE CHART</b>		DOCUMENT NO. SD-75784-001	

THIS DRAWING CONTAINS INFORMATION THAT IS PROPRIETARY TO MOLEX INCORPORATED AND SHOULD NOT BE USED WITHOUT WRITTEN PERMISSION

# VERTICAL CONNECTOR WITH SMT SHELL PCB FOOT PRINT

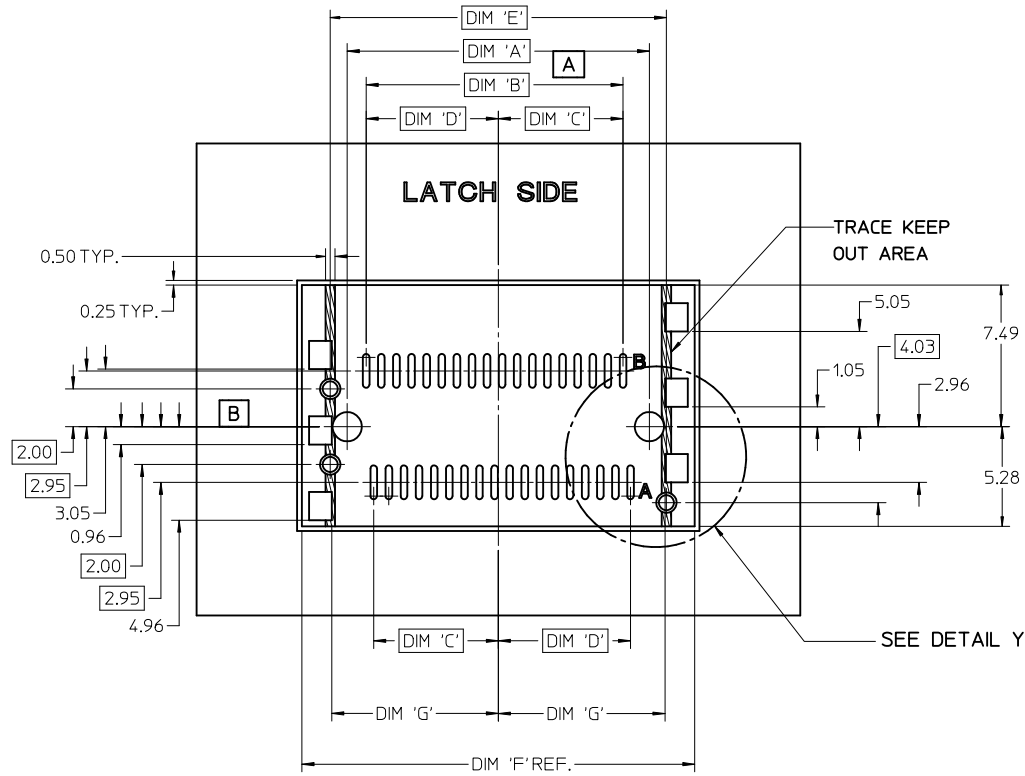

36 CIRCUIT SHOWN

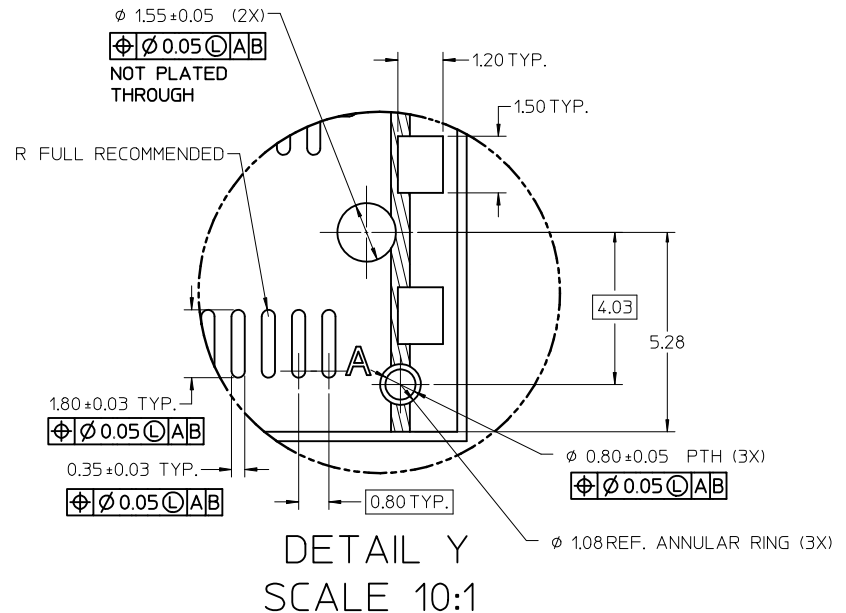

DETAIL Y  
SCALE 10:1

PEG TO PEG  
FIRST TO  
LAST PAD  
CENTERLINE  
TO PAD  
CENTERLINE  
TO PAD  
SHELL PEG  
TO PEG  
SHELL  
FOOTPRINT WIDTH  
CENTERLINE  
TO PAD EDGE

CIRCUIT SIZE	DIM 'A'	DIM 'B'	DIM 'C'	DIM 'D'	DIM 'E'	DIM 'F'	DIM 'G'
26	12.00	9.60	4.60	5.00	13.80	16.80	6.825
36	16.00	13.60	6.60	7.00	17.80	20.80	8.825
50	21.60	19.20	9.40	9.80	23.40	26.40	11.625
68	28.80	26.40	13.00	13.40	30.60	33.60	15.225

SEE SHEET 1  
EC NO: UCP2012-2460  
DRAWN BY: DRWINKLANG 2012/02/03  
CHKD: MBANAKIS  
APPR: MBANAKIS 2012/02/07  
REV: D4

QUALITY SYMBOLS  
  
 GENERAL TOLERANCES (UNLESS SPECIFIED)  

	mm	INCH
4 PLACES	± 0.13	± 0.005
3 PLACES	± 0.25	± 0.010
2 PLACES	± 0.38	± 0.015
1 PLACE	± 0.51	± 0.020

 ANGULAR ±1/2°  
 DRAFT WHERE APPLICABLE  
 MUST REMAIN  
 WITHIN DIMENSIONS

DIMENSION STYLE  
**MM ONLY**  
 DRAWN BY: KLANG DATE: 02/09/05  
 CHECKED BY: JSWENSON DATE: 02/09/05  
 APPROVED BY: MBANAKIS DATE: 02/02/05  
 MATERIAL NO.  
**SEE CHART**  
 SIZE: C

iPass™ IS A TRADEMARK OF MOLEX  
 SCALE 5:1 DESIGN UNITS METRIC THIRD ANGLE PROJECTION  
**I-PASS VERT CONNECTOR  
 INTERNAL ASSY W/SHELL  
 0.8MM PITCH I/O**  
  
**MOLEX INCORPORATED**  
 DOCUMENT NO. SD-75784-001 SHEET NO. 10 OF 12  
 THIS DRAWING CONTAINS INFORMATION THAT IS PROPRIETARY TO MOLEX INCORPORATED AND SHOULD NOT BE USED WITHOUT WRITTEN PERMISSION

# VERTICAL CONNECTOR WITH SHELL PCB FOOT PRINT DESCRIPTIONS

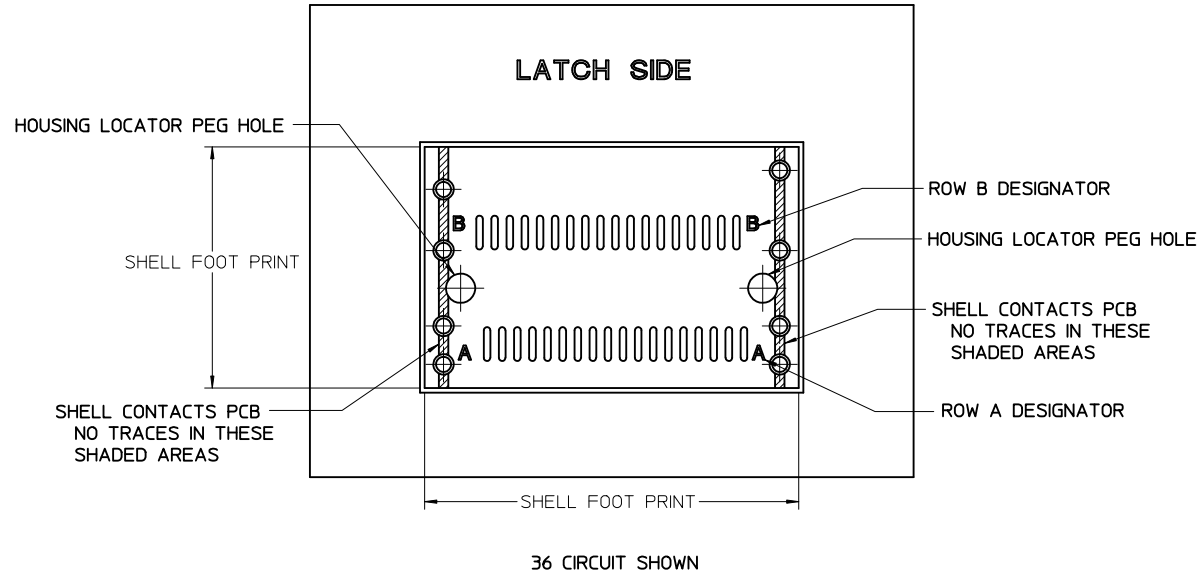

iPass™ IS A TRADEMARK OF MOLEX

SEE SHEET 1 EC NO: UCP2012-2460 DRINKLANG 2012/02/03 CHKD: APPR: MBANAK IS 2012/02/07 REV:	QUALITY SYMBOLS ▼=0 ▽=0	GENERAL TOLERANCES (UNLESS SPECIFIED)	DIMENSION STYLE <b>MM ONLY</b>	SCALE <b>5:1</b>	DESIGN UNITS METRIC	THIRD ANGLE PROJECTION																
			<table border="1" style="width: 100%; border-collapse: collapse;"> <thead> <tr> <th></th> <th>mm</th> <th>INCH</th> </tr> </thead> <tbody> <tr> <td>4 PLACES</td> <td>± ---</td> <td>± ---</td> </tr> <tr> <td>3 PLACES</td> <td>± ---</td> <td>± ---</td> </tr> <tr> <td>2 PLACES</td> <td>± 0.13</td> <td>± ---</td> </tr> <tr> <td>1 PLACE</td> <td>± 0.25</td> <td>± ---</td> </tr> </tbody> </table> ANGULAR ±1/2°		mm	INCH	4 PLACES	± ---	± ---	3 PLACES	± ---	± ---	2 PLACES	± 0.13	± ---	1 PLACE	± 0.25	± ---	DRAWN BY KLANG	DATE 02/09/05	TITLE <b>I-PASS VERT CONNECTOR INTERNAL ASSY W/SHELL 0.8MM PITCH I/O</b>	
		mm	INCH																			
	4 PLACES	± ---	± ---																			
3 PLACES	± ---	± ---																				
2 PLACES	± 0.13	± ---																				
1 PLACE	± 0.25	± ---																				
			CHECKED BY JSWENSON	DATE 02/09/05																		
		DRAFT WHERE APPLICABLE MUST REMAIN WITHIN DIMENSIONS	APPROVED BY MBANAK IS	DATE 02/02/05	<b>MOLEX INCORPORATED</b>																	
D4			MATERIAL NO. <b>SEE CHART</b>	DOCUMENT NO. <b>SD-75784-001</b>			SHEET NO. 11 OF 12															

# MATING INTERFACE (FOR REFERENCE ONLY)

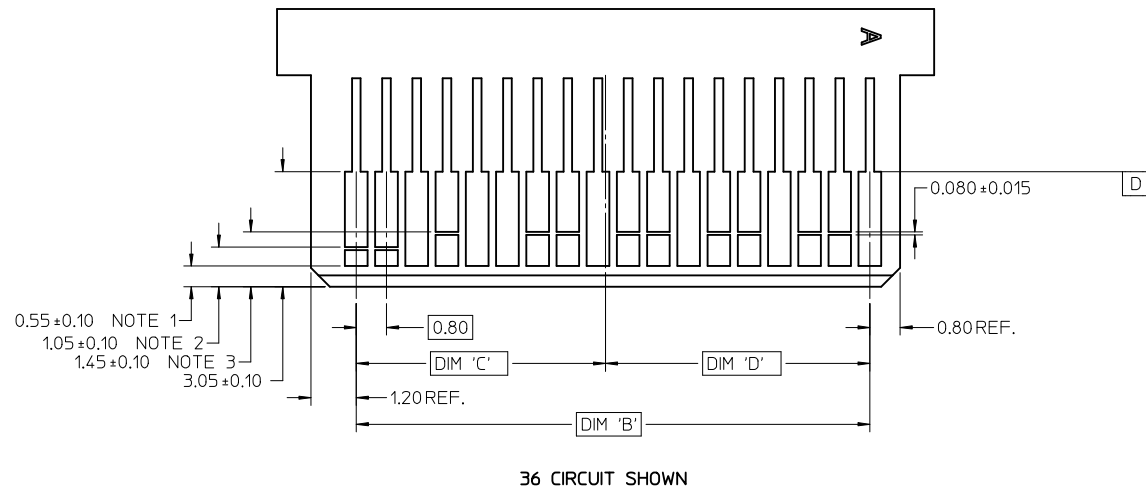
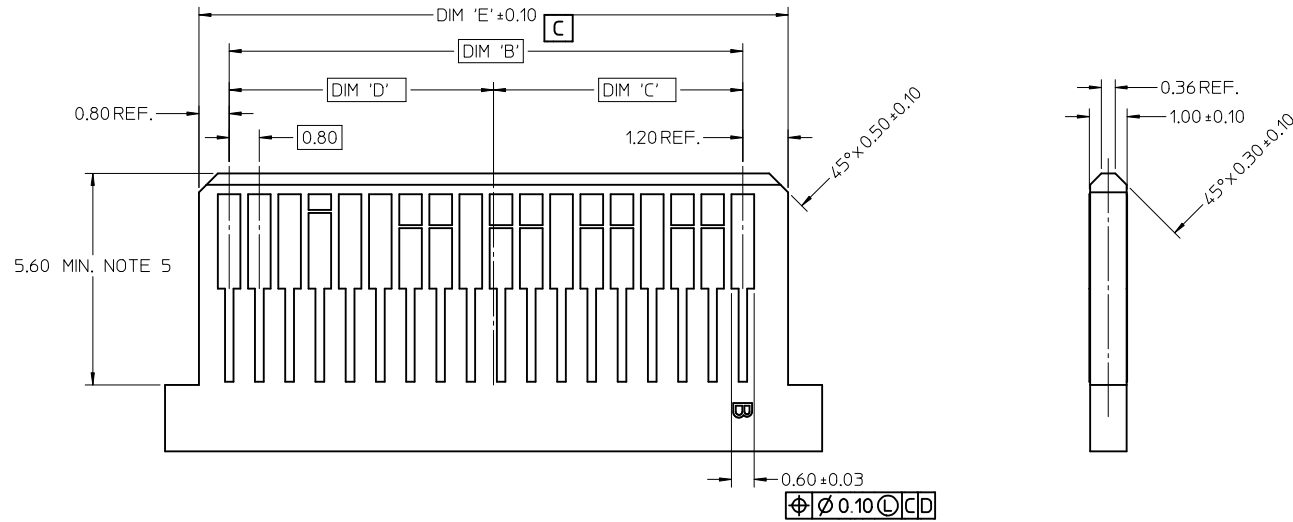

**NOTES:**

1. PAD CONFIGURATION FOR FIRST MATE.
2. PAD CONFIGURATION FOR SECOND MATE.
3. PAD CONFIGURATION FOR THIRD MATE.  
(HIGH SPEED SIGNALS)
4. FOR PIN ASSIGNMENTS AND MATING SEQUENCE  
(1ST, 2ND, 3RD), SEE APPLICABLE  
SPECIFICATION.
5. MINIMUM STEP REQUIRED IF PCB MADE  
WIDER THAN TOUNGE.

iPass™ IS A TRADEMARK OF MOLEX

CIRCUIT SIZE	TERM/SIDE 'N'	DIM 'B'	DIM 'C'	DIM 'D'	DIM 'E'
26	13	9.60	4.60	5.00	11.60
36	18	13.60	6.60	7.00	15.60
50	25	19.20	9.40	9.80	21.20
68	34	26.40	13.00	13.40	28.40

SEE SHEET 1 EC NO: UCP2012-2460 DRINKLANG 2012/02/03 CHKD: MBANAK IS APPR: MBANAK IS 2012/02/07	QUALITY SYMBOLS
	▽=0
	▽=0
	REV: D4

GENERAL TOLERANCES (UNLESS SPECIFIED)	
mm	INCH
4 PLACES ± ---	± ---
3 PLACES ± ---	± ---
2 PLACES ± 0.13	± ---
1 PLACE ± 0.25	± ---
ANGULAR ±1/2°	
DRAFT WHERE APPLICABLE MUST REMAIN WITHIN DIMENSIONS	

DIMENSION STYLE <b>MM ONLY</b>	
DRAWN BY	DATE
CHECKED BY	DATE
APPROVED BY	DATE
MBANAK IS	02/02/05
SEE CHART	
SIZE	C

SCALE 10:1	DESIGN UNITS METRIC	THIRD ANGLE PROJECTION
TITLE <b>I-PASS VERT CONNECTOR INTERNAL ASSY W/SHELL 0.8MM PITCH I/O</b>		
molex <b>MOLEX INCORPORATED</b>		DOCUMENT NO. <b>SD-75784-001</b>
		SHEET NO. 12 OF 12
THIS DRAWING CONTAINS INFORMATION THAT IS PROPRIETARY TO MOLEX INCORPORATED AND SHOULD NOT BE USED WITHOUT WRITTEN PERMISSION		