

NO. OF CKT'S.	DIM. A	DIM. B
1		.122±.010 (3.10±.25)
2	.100±.004 (2.54±.10)	.222±.010 (5.64±.25)
3	.200±.004 (5.08±.10)	.322±.010 (8.18±.25)
4	.300±.004 (7.62±.10)	.422±.010 (10.72±.25)
5	.400±.004 (10.16±.10)	.522±.010 (13.26±.25)
6	.500±.005 (12.70±.13)	.622±.010 (15.80±.25)
7	.600±.005 (15.24±.13)	.722±.011 (18.34±.28)
8	.700±.005 (17.78±.13)	.822±.011 (20.88±.28)
9	.800±.006 (20.32±.15)	.922±.011 (23.42±.28)
10	.900±.006 (22.86±.15)	1.022±.012 (25.96±.30)
11	1.000±.006 (25.40±.15)	1.122±.012 (28.50±.30)
12	1.100±.006 (27.94±.15)	1.222±.012 (31.04±.30)
13	1.200±.007 (30.48±.18)	1.322±.012 (33.58±.30)
14	1.300±.007 (33.02±.18)	1.422±.013 (36.12±.33)
15	1.400±.011 (35.56±.28)	1.522±.013 (38.66±.33)
16	1.500±.011 (38.10±.28)	1.622±.013 (41.20±.33)
17	1.600±.011 (40.64±.28)	1.722±.013 (43.74±.33)
18	1.700±.011 (43.18±.28)	1.822±.014 (46.28±.36)
19	1.800±.011 (45.72±.28)	1.922±.014 (48.82±.36)
20	1.900±.011 (48.26±.28)	2.022±.014 (51.36±.36)
21	2.000±.012 (50.80±.30)	2.122±.015 (53.90±.38)
22	2.100±.012 (53.34±.30)	2.222±.015 (56.44±.38)
23	2.200±.012 (55.88±.30)	2.322±.015 (58.98±.38)
24	2.300±.012 (58.42±.30)	2.422±.016 (61.52±.41)
25	2.400±.013 (60.96±.33)	2.522±.016 (64.06±.41)
26	2.500±.013 (63.50±.33)	2.622±.016 (66.60±.41)
27	2.600±.013 (66.04±.33)	2.722±.016 (69.14±.41)
28	2.700±.013 (68.58±.33)	2.822±.017 (71.68±.43)

NOTES:

1. DIMENSIONS GIVEN ACROSS CENTERLINES ARE SYMMETRICAL ABOUT THOSE CENTERLINES WITHIN HALF THE TOTAL TOLERANCES.
2. THIS HOUSING FOR USE WITH SHROUDED TERMINAL 7879.
3. THIS PRODUCT COMPLIES WITH MOLEX PRODUCT SPEC. NO. 7879.
4. SPECIAL SUPPORT MAY BE REQUIRED FOR PRINTED CIRCUIT BOARDS USED WITH 10 OR MORE CIRCUIT CONNECTORS.
5. INSERTION AND WITHDRAWL FORCES RANGE FROM 1.3 TO 1.9 POUNDS PER CIRCUIT.

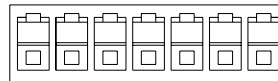
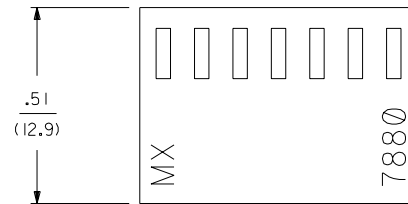
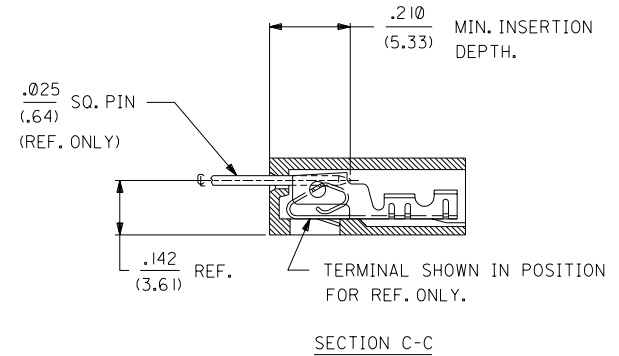
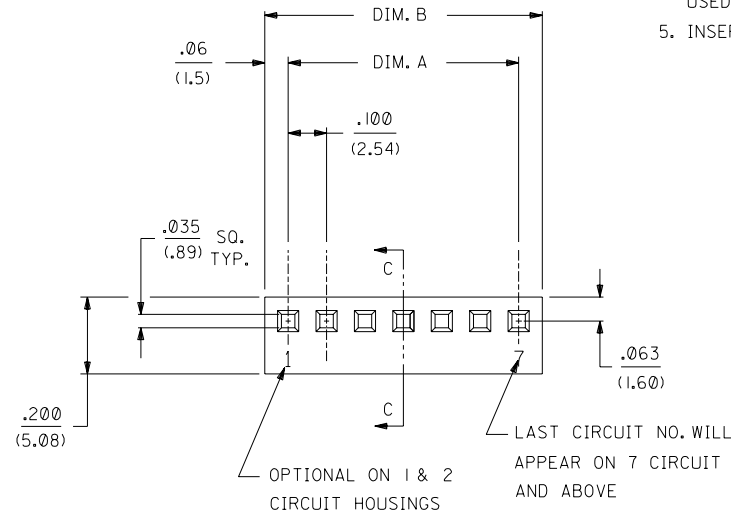

7880 - N * - *

NO. OF CKTS.

VOID CODE
NO. CORRESPONDS TO
CKT. NO. VOIDED.
MULT. VOIDS START WITH 51.

OPTION CODE		
OPT. CODE	RAMP	MATERIAL
A	NONE	NYLON, 94V-0, COLOR-WHITE
B	STD. RAMP	NYLON, 94V-0, COLOR-WHITE
C	POL. RAMP	NYLON, 94V-0, COLOR-WHITE

DIMENSIONS SHOWN (METRIC) INCH UNLESS OTHERWISE SPECIFIED TOLERANCES: ANGULAR ± 1/2°		<input checked="" type="checkbox"/> = 0 <input type="checkbox"/> = 0 REVISE ONLY ON CAD SYSTEM									
<table border="1"> <tr> <th>INCH</th> <th>METRIC</th> </tr> <tr> <td>3 PLACE ± .010</td> <td>---</td> </tr> <tr> <td>2 PLACE ± .014</td> <td>± 0.25</td> </tr> <tr> <td>1 PLACE ---</td> <td>± 0.35</td> </tr> </table>		INCH	METRIC	3 PLACE ± .010	---	2 PLACE ± .014	± 0.25	1 PLACE ---	± 0.35	TITLE (2.54)/.100 KK, HOUSING FOR SHROUDED CRIMP TYPE TERMINAL	
INCH	METRIC										
3 PLACE ± .010	---										
2 PLACE ± .014	± 0.25										
1 PLACE ---	± 0.35										
DRAFT WHERE APPLICABLE MUST REMAIN WITHIN DIMENSIONS		SHEET NO. DATE 1 OF 2 08/24/88									
DRWG. BY: GUZIK CHK'D. BY: PATEL APP'D. BY: LENZ SCALE:		PART NO. SD-7880 SEE CHART									
LTR. REVISIONS		DIV. SIZE									

7880

2 L
1 L I

MFG. SH. REV.

7880-NA-*			7880-NB-*			7880-NC-*		
PART NO.	ENG. NO.	VOID CKT.	PART NO.	ENG. NO.	VOID CKT.	PART NO.	ENG. NO.	VOID CKT.
10-01-2019	7880-1A		10-11-2013	7880-1B		N/A	7880-1C	
10-01-2029	7880-2A		10-11-2023	7880-2B		10-11-2024	7880-2C	
10-01-2039	7880-3A		10-11-2033	7880-3B		10-11-2034	7880-3C	
10-01-2049	7880-4A		10-11-2043	7880-4B		10-11-2044	7880-4C	
10-01-2059	7880-5A		10-11-2053	7880-5B		10-11-2054	7880-5C	
10-01-2069	7880-6A		10-11-2063	7880-6B		10-11-2064	7880-6C	
10-01-2079	7880-7A		10-11-2073	7880-7B		10-11-2074	7880-7C	
10-01-2089	7880-8A		10-11-2083	7880-8B		10-11-2084	7880-8C	
10-01-2099	7880-9A		10-11-2093	7880-9B		10-11-2094	7880-9C	
10-01-2109	7880-10A		10-11-2103	7880-10B		10-11-2104	7880-10C	
10-01-2119	7880-11A		10-11-2113	7880-11B		10-11-2114	7880-11C	
10-01-2129	7880-12A		10-11-2123	7880-12B		10-11-2124	7880-12C	
10-01-2139	7880-13A		10-11-2133	7880-13B		10-11-2134	7880-13C	
10-01-2149	7880-14A		10-11-2143	7880-14B		10-11-2144	7880-14C	
10-01-2159	7880-15A		10-11-2153	7880-15B		10-11-2154	7880-15C	
10-01-2169	7880-16A		10-11-2163	7880-16B		10-11-2164	7880-16C	
10-01-2179	7880-17A		10-11-2173	7880-17B		10-11-2174	7880-17C	
10-01-2189	7880-18A		10-11-2183	7880-18B		10-11-2184	7880-18C	
10-01-2199	7880-19A		10-11-2193	7880-19B		10-11-2194	7880-19C	
10-01-2209	7880-20A		10-11-2203	7880-20B		10-11-2204	7880-20C	
10-01-2219	7880-21A		10-11-2213	7880-21B		10-11-2214	7880-21C	
10-01-2229	7880-22A		10-11-2223	7880-22B		10-11-2224	7880-22C	
10-01-2239	7880-23A		10-11-2233	7880-23B		10-11-2234	7880-23C	
10-01-2249	7880-24A		10-11-2243	7880-24B		10-11-2244	7880-24C	
10-01-2259	7880-25A		10-11-2253	7880-25B		10-11-2254	7880-25C	
10-01-2269	7880-26A		10-11-2263	7880-26B		10-11-2264	7880-26C	
10-01-2279	7880-27A		10-11-2273	7880-27B		10-11-2274	7880-27C	
10-01-2289	7880-28A		10-11-2283	7880-28B		10-11-2284	7880-28C	
			10-11-2052	7880-5B-2	2			
			10-11-2092	7880-9B-2	2			
			10-11-2105	7880-10B-4	4			

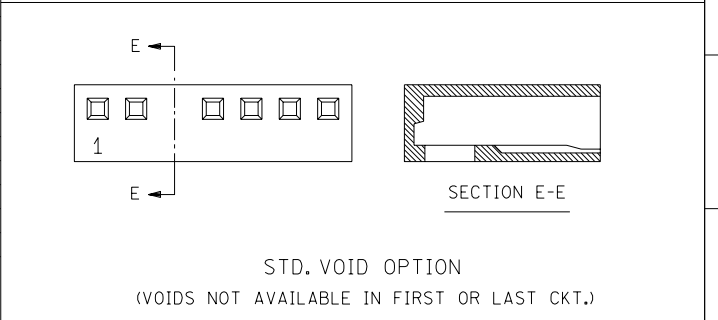
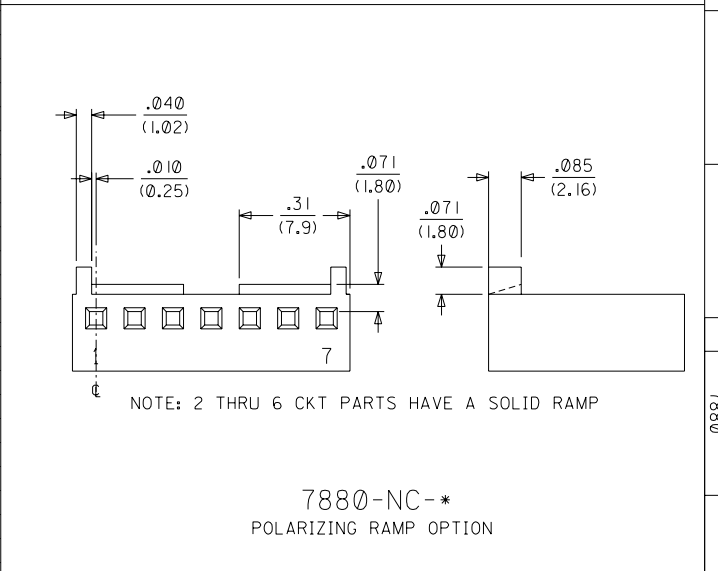
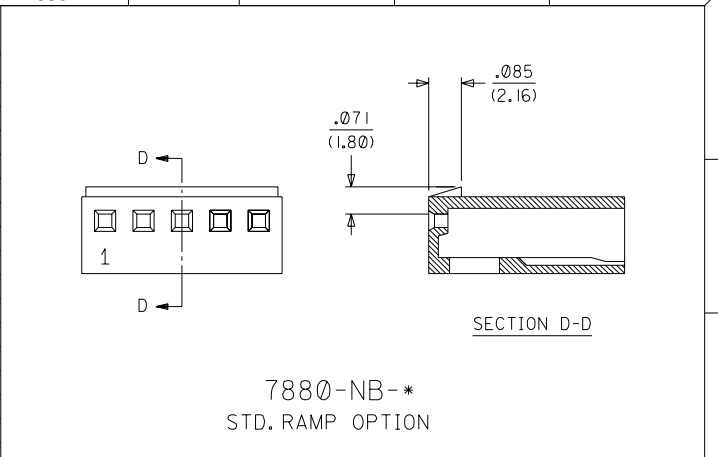

SEE SHEET I	SEE SHEET I	DIMENSIONS SHOWN (METRIC) INCH UNLESS OTHERWISE SPECIFIED TOLERANCES: ANGULAR ± 1/2° <table border="1"> <tr><th colspan="2">INCH</th><th>METRIC</th></tr> <tr><td>3 PLACE</td><td>± .010</td><td></td></tr> <tr><td>2 PLACE</td><td>± .014</td><td>± 0.25</td></tr> <tr><td>1 PLACE</td><td></td><td>± 0.36</td></tr> </table> DRAFT WHERE APPLICABLE MUST REMAIN WITHIN DIMENSIONS DRWG. BY: GUZIK CHK'D. BY: PATEL APP'D. BY: LENZ SCALE:	INCH		METRIC	3 PLACE	± .010		2 PLACE	± .014	± 0.25	1 PLACE		± 0.36	SEE SHEET I	SEE SHEET I	REVISIONS LTR. REVISIONS LTR.	THIS DRAWING CONTAINS INFORMATION THAT IS PROPRIETARY TO MOLEX INC. AND SHOULD NOT BE USED WITHOUT WRITTEN PERMISSION	TITLE: (2.54)/.100 KK, HOUSING FOR SHROUDED CRIMP TYPE TERMINAL SHEET NO. 2 DATE 08/24/88 MOLEX INCORPORATED U.S.A. LITSE,ILL. 60532 PART NO. SEE CHART DRWG. NO. SD-7880
INCH			METRIC																
3 PLACE	± .010																		
2 PLACE	± .014		± 0.25																
1 PLACE			± 0.36																
SEE SHEET I	SEE SHEET I		SEE SHEET I	SEE SHEET I															
SEE SHEET I	SEE SHEET I	SEE SHEET I	SEE SHEET I																
SEE SHEET I	L	SEE SHEET I	SEE SHEET I																
SEE SHEET I	K3	SEE SHEET I	SEE SHEET I																
SEE SHEET I	H	SEE SHEET I	SEE SHEET I																