

NOTES:

- 1 - HOUSING MATERIAL: GLASS FILLED LCP, COLOR: BLACK.
- 2 - TERMINAL MATERIAL: PHOSPHOR BRONZE
- 3 - SEE SHEET 2 FOR CIRCUIT SIZE, PART NUMBERS AND OVER-ALL DIMENSIONS.
- 4 - FOR ILLUSTRATION, 6 CIRCUIT ASSEMBLY SHOWN.
- 5 - REFER TO PRODUCT SPECIFICATION PS-79107.
- 6 - PACKAGING PER PK-70873-0180.
- 7 - SEE SHEET 3 FOR VOIDED ASSEMBLIES.
- 8 - CKTS. NUMBERED FROM LEFT TO RIGHT WHEN PART IS VIEWED FROM TOP WITH RECESS ON RIGHT AS SHOWN.

PLATING OPTION :

- (4) 0.76µm MIN. GOLD PLATE IN SELECTED AREA AND 1.91µm MIN. TIN IN SELECTED AREA OVER 1.27µm MIN. NICKEL OVER-ALL
- (5) 0.38µm MIN. GOLD PLATE IN SELECTED AREA AND 1.91µm MIN. TIN IN SELECTED AREA OVER 1.27µm MIN. NICKEL OVER-ALL
- (6) 0.13µm MIN. GOLD PLATE IN SELECTED AREA AND 1.91µm MIN. TIN IN SELECTED AREA OVER 1.27µm MIN. NICKEL OVER-ALL

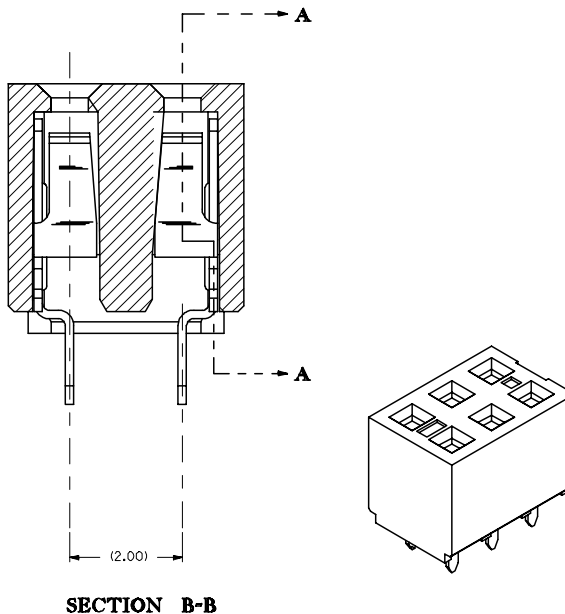
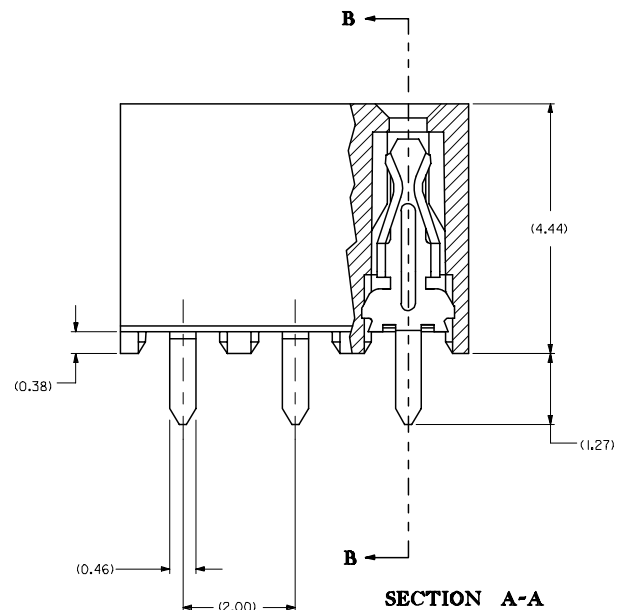

REVISE PDR#S1436 EC NO: S2007-0532 DRWN:KELIM CHKD:M.LONG APPR:SKTOH	2006/12/06 2006/12/07 2006/12/07	QUALITY SYMBOLS ▽=0 ▽=0	GENERAL TOLERANCES (UNLESS SPECIFIED)		DIMENSION STYLE MM ONLY		SCALE NTS	DESIGN UNITS METRIC	THIRD ANGLE PROJECTION			
				mm	INCH	DRAWN BY AAB	DATE 1998/05/15	TITLE 2MM DUAL ROW, FFC VERTICAL RECEPTACLE				
			4 PLACES	± ---	± ---	CHECKED BY MJM	DATE 1998/05/15	APPROVED BY WAZ				
			3 PLACES	± 0.10	± ---	APPROVED BY DATE 1998/05/15		MATERIAL NO. DOCUMENT NO. SDA-79108-****				
2 PLACES	± 0.15	± ---	ANGULAR ±1/2°		SEE TABLE		SHEET NO. 1 OF 4					
1 PLACE	± ---	± ---	DRAFT WHERE APPLICABLE MUST REMAIN WITHIN DIMENSIONS		SIZE A3		THIS DRAWING CONTAINS INFORMATION THAT IS PROPRIETARY TO MOLEX INCORPORATED AND SHOULD NOT BE USED WITHOUT WRITTEN PERMISSION					

10 9 8 7 6 5 4 3 2 1

CKT. SIZE	DIM. "A"	DIM. "B"	PLATING OPTION 5		PLATING OPTION 4		PLATING OPTION 6	
			EDP NO.	ENG. NO.	EDP NO.	ENG. NO.	EDP NO.	ENG. NO.
04	(2.00)	(4.19)	791081001	79108-1001	791081051	79108-1051	NOT TOOLED	79108-1101
06	(4.00)	(6.19)	791081002	79108-1002	791081052	79108-1052		79108-1102
08	(6.00)	(8.19)	791081003	79108-1003	791081053	79108-1053		79108-1103
10	(8.00)	(10.19)	791081004	79108-1004	791081054	79108-1054		79108-1104
12	(10.00)	(12.19)	791081005	79108-1005	791081055	79108-1055		79108-1105
14	(12.00)	(14.19)	791081006	79108-1006	791081056	79108-1056		79108-1106
16	(14.00)	(16.19)	791081007	79108-1007	791081057	79108-1057		79108-1107
18	(16.00)	(18.19)	791081008	79108-1008	791081058	79108-1058		79108-1108
20	(18.00)	(20.19)	791081009	79108-1009	791081059	79108-1059		79108-1109
22	(20.00)	(22.19)	791081010	79108-1010	791081060	79108-1060		79108-1110
24	(22.00)	(24.19)	791081011	79108-1011	791081061	79108-1061		79108-1111
26	(24.00)	(26.19)	791081012	79108-1012	791081062	79108-1062		79108-1112
28	(26.00)	(28.19)	791081013	79108-1013	791081063	79108-1063		79108-1113
30	(28.00)	(30.19)	791081014	79108-1014	791081064	79108-1064		79108-1114
32	(30.00)	(32.19)	791081015	79108-1015	791081065	79108-1065		79108-1115
34	(32.00)	(34.19)	791081016	79108-1016	791081066	79108-1066		79108-1116
36	(34.00)	(36.19)	791081017	79108-1017	791081067	79108-1067		79108-1117
38	(36.00)	(38.19)	791081018	79108-1018	791081068	79108-1068		79108-1118
40	(38.00)	(40.19)	791081019	79108-1019	791081069	79108-1069		79108-1119
42	(40.00)	(42.19)	791081020	79108-1020	791081070	79108-1070		79108-1120
44	(42.00)	(44.19)	791081021	79108-1021	791081071	79108-1071		79108-1121
46	(44.00)	(46.19)	791081022	79108-1022	791081072	79108-1072		79108-1122
48	(46.00)	(48.19)	791081023	79108-1023	791081073	79108-1073		79108-1123
50	(48.00)	(50.19)	791081024	79108-1024	791081074	79108-1074		79108-1124

REVISE PDR#S1436 EC NO: S2007-0532 DRWN:KELIM 2006/12/06 CHKD:M.LONG 2006/12/07 APPR:SKTOH 2006/12/07	QUALITY SYMBOLS ▽=0 ▽=0	GENERAL TOLERANCES (UNLESS SPECIFIED)		DIMENSION STYLE MM ONLY		SCALE NTS	DESIGN UNITS METRIC	THIRD ANGLE PROJECTION		
				mm	INCH	DRAWN BY AAB	DATE 1998/05/15	TITLE 2MM DUAL ROW, FFC VERTICAL RECEPTACLE		
				4 PLACES ± ---	± ---	CHECKED BY MJM	DATE 1998/05/15			
				3 PLACES ± 0.10	± ---	APPROVED BY WAZ	DATE 1998/05/15	MOLEX INCORPORATED		
		2 PLACES ± 0.15	± ---	MATERIAL NO.		DOCUMENT NO.	SHEET NO.			
		1 PLACE ± ---	± ---	DRAFT WHERE APPLICABLE MUST REMAIN WITHIN DIMENSIONS		SEE TABLE		SDA-79108-****		
		ANGULAR ±1/2°		SIZE A3		THIS DRAWING CONTAINS INFORMATION THAT IS PROPRIETARY TO MOLEX INCORPORATED AND SHOULD NOT BE USED WITHOUT WRITTEN PERMISSION				

9 8 7 6 5 4 3 2 1

MOLDED VOID OPTION

CKT. SIZE	ASSEMBLY		VOID LOCATION(S) SEE SHEET 1 FOR CONVENTION		PLATING OPTION	DIM. "A"	DIM. "B"
	EDP NO.	ENG. NO.	ROW	CKT. NO.(S)			
44	791085003	79108-5003	ROW A	13	4	(42.00)	(44.19)
44	791085004	79108-5004	ROW B	10	4	(42.00)	(44.19)

NOTES:

1. TERMINALS WILL BE PRESENT IN VOIDED LOCATIONS HOWEVER, PIN WINDOWS WILL BE CLOSED.
2. VOIDS CAN ONLY BE PRESENT IN ONE ROW OF THE CONNECTOR.

REVISE PDR#S1436 EC NO: S2007-0532 DRWN:KFLM CHKD:M.LONG APPR:SKTOH	2006/12/06 2006/12/07 2006/12/07	DESCRIPTION REV	QUALITY SYMBOLS	GENERAL TOLERANCES (UNLESS SPECIFIED) <table border="1" style="width: 100%; border-collapse: collapse;"> <tr> <th></th> <th>mm</th> <th>INCH</th> </tr> <tr> <td>4 PLACES</td> <td>± ---</td> <td>± ---</td> </tr> <tr> <td>3 PLACES</td> <td>± 0.10</td> <td>± ---</td> </tr> <tr> <td>2 PLACES</td> <td>± 0.15</td> <td>± ---</td> </tr> <tr> <td>1 PLACE</td> <td>± ---</td> <td>± ---</td> </tr> <tr> <td colspan="3" style="text-align: center;">ANGULAR ±1/2°</td> </tr> </table>		mm	INCH	4 PLACES	± ---	± ---	3 PLACES	± 0.10	± ---	2 PLACES	± 0.15	± ---	1 PLACE	± ---	± ---	ANGULAR ±1/2°			DIMENSION STYLE MM ONLY	SCALE NTS	DESIGN UNITS METRIC	THIRD ANGLE PROJECTION 2MM DUAL ROW, FFC VERTICAL RECEPTACLE MOLEX INCORPORATED SDA-79108-****
					mm	INCH																				
			4 PLACES		± ---	± ---																				
			3 PLACES		± 0.10	± ---																				
2 PLACES	± 0.15	± ---																								
1 PLACE	± ---	± ---																								
ANGULAR ±1/2°																										
▽=0 ◻=0	DRAWN BY AAB	DATE 1998/05/15	TITLE	APPROVED BY WAZ	DATE 1998/05/15	MATERIAL NO.	DOCUMENT NO.																			
DRAFT WHERE APPLICABLE MUST REMAIN WITHIN DIMENSIONS	SEE TABLE		SHEET NO. 3 OF 4	THIS DRAWING CONTAINS INFORMATION THAT IS PROPRIETARY TO MOLEX INCORPORATED AND SHOULD NOT BE USED WITHOUT WRITTEN PERMISSION																						
SIZE A3																										

10

9

8

7

6

5

4

3

2

1

ASSEMBLY P/N PACKED IN T&R	CKT SIZE	PLATING OPTION	DIM A	DIM B	(F)	(Bo)	(W)
79108-6001	16	5	14.00	16.19	11.50	16.60	24.00

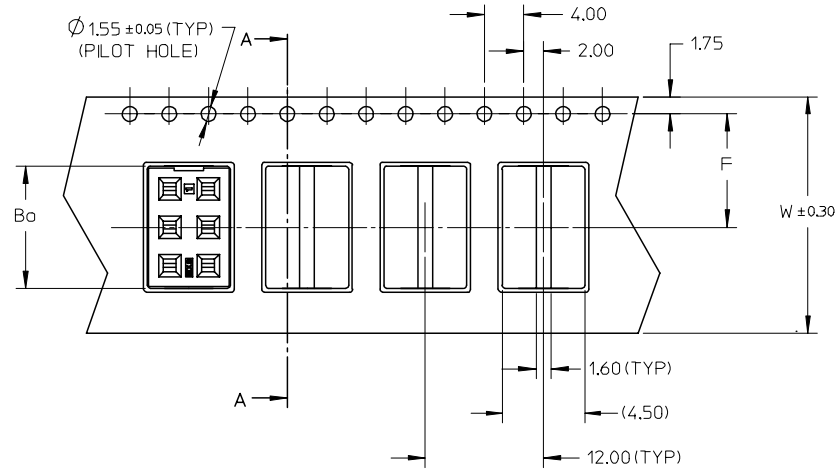
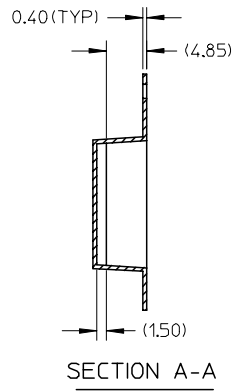

NOTES:

1. LEADER AND TRAILER TAPE

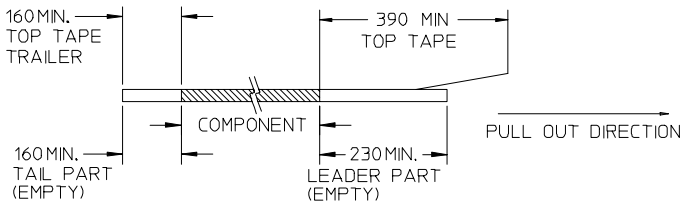

2. PEELING OFF FORCE OF THE TOP TAPE: 20-80gf. (PEELING DIRECTION AS SHOWN IN FOLLOWING FIGURE)

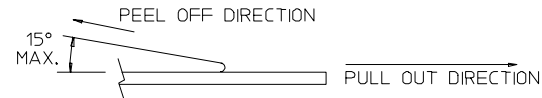

- 3. PACKAGING STANDARD IS AS PER EIA-481.
- 4. THE TAPE IS TREATED FOR ANTI-STATIC.
- 5. MATERIAL: CLEAR POLYSTYRENE.
- 6. TAPE & REEL QUANTITY = 800 PCS/REEL

CUSTOMER PULL OUT DIRECTION

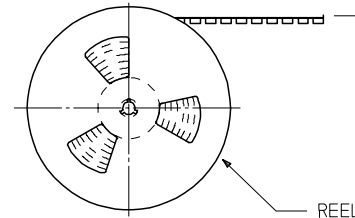

TAPE AND REEL ORIENTATION

REVISE PDR#S1436	2006/12/07	DESCRIPTION
EC NO: S2007-0532	2006/12/07	
DRWN:KELIM	2006/12/07	
CHKD:M.LONG	2006/12/07	
APPR:SKTOH	2006/12/07	
F2	REV	

QUALITY SYMBOLS	▽=0
	∇=0

GENERAL TOLERANCES (UNLESS SPECIFIED)	
	mm INCH
4 PLACES	± --- ± ---
3 PLACES	± 0.10 ± ---
2 PLACES	± 0.15 ± ---
1 PLACE	± --- ± ---
ANGULAR ±1/2°	
DRAFT WHERE APPLICABLE MUST REMAIN WITHIN DIMENSIONS	

DIMENSION STYLE MM ONLY	
DRAWN BY	DATE
AAB	1998/05/15
CHECKED BY	DATE
MJM	1998/05/15
APPROVED BY	DATE
WAZ	1998/05/15
MATERIAL NO.	
SEE TABLE	
SIZE	A3

SCALE NTS	DESIGN UNITS METRIC	THIRD ANGLE PROJECTION
TITLE 2MM DUAL ROW, FFC VERTICAL RECEPTACLE		
MOLEX INCORPORATED		
DOCUMENT NO. SDA-79108-****	SHEET NO. 4 OF 4	
THIS DRAWING CONTAINS INFORMATION THAT IS PROPRIETARY TO MOLEX INCORPORATED AND SHOULD NOT BE USED WITHOUT WRITTEN PERMISSION		

9

8

7

6

5

4

3

2

1