

LOOSE PIECE		TAPE MOUNTED		CONTINUOUS STRIP (C)		SPECIFICATIONS											
MATERIAL NUMBER	ENGINEERING NUMBER	MATERIAL NUMBER	ENGINEERING NUMBER	MATERIAL NUMBER	ENGINEERING NUMBER	INS. COLOR	WIRE AWG	RANGE	MM ²	FITS MALE TAB SIZE	STOCK THICKNESS	"L" MAX.	"I" MAX.	"W" MAX.	"D" ±.01	"G" NOM.	MWID
190190012	AA-8140	190190013	AA-8140T	190190020	AAZ-8140	RED	22-18	0.25-1.5	.250x.032 (6.35X0.81)	.016 (0.41)	.865 (21.97)	.43 (10.9)	.301 (7.65)	.156 (3.96)	.31 (7.9)	.115 (2.92)	
190190031	BB-8141	190190033	BB-8141T	190190036	BBZ-8141	BLUE	16-14	1.0-2.5	.250x.032 (6.35X0.81)	.016 (0.41)	.865 (21.97)	.43 (10.9)	.301 (7.65)	.156 (3.96)	.31 (7.9)	.138 (3.51)	
190190052	P-8142	190190054	P-8142T	190190057	PZ-8142	YELLOW	14-12	1.65-4.2	.250x.032 (6.35X0.81)	.016 (0.41)	.865 (21.97)	.43 (10.9)	.301 (7.65)	.156 (3.96)	.31 (7.9)	.170 (4.32)	
190190037	C-8143	190190038	C-8143T	-	-	YELLOW	10-12	4.0-6.0	.250x.032 (6.35X0.81)	.018 (0.46)	1.011 (25.68)	.57 (14.5)	.301 (7.65)	.156 (3.96)	.31 (7.9)	.225 (5.70)	
190190014	AA-8190	190190016	AA-8190T	190190021	AAZ-8190	RED	22-18	0.25-1.5	.205x.020 (5.21X0.51)	.016 (0.41)	.789 (20.04)	.43 (10.9)	.251 (6.38)	.125 (3.18)	.25 (6.4)	.115 (2.92)	
190190034	BB-8191	190190064	BB-8191T	-	-	BLUE	16-14	1.0-2.5	.205x.020 (5.21X0.51)	.016 (0.41)	.789 (20.04)	.43 (10.9)	.251 (6.38)	.125 (3.18)	.25 (6.4)	.115 (2.92)	
190190015	AA-8190-032	190190058	AA-8190-032T	-	-	RED	22-18	0.25-1.5	.205x.032 (5.21X0.81)	.016 (0.41)	.789 (20.04)	.43 (10.9)	.251 (6.38)	.125 (3.18)	.25 (6.4)	.115 (2.92)	
190190035	BB-8191-032	190190063	BB-8191-032T	-	-	BLUE	16-14	1.0-2.5	.205x.032 (5.21X0.81)	.016 (0.41)	.789 (20.04)	.43 (10.9)	.251 (6.38)	.125 (3.18)	.25 (6.4)	.115 (2.92)	
190190008	AA-8137-032	190190009	AA-8137-032T	190190019	AAZ-8137-032	RED	22-18	0.25-1.5	.187x.032 (4.75X0.81)	.016 (0.41)	.789 (20.04)	.43 (10.9)	.238 (6.05)	.125 (3.18)	.25 (6.4)	.138 (3.51)	
190190028	BB-8138-032	190190029	BB-8138-032T	190190080	BBZ-8138-032	BLUE	16-14	1.0-2.5	.187x.032 (4.75X0.81)	.016 (0.41)	.789 (20.04)	.43 (10.9)	.238 (6.05)	.125 (3.18)	.25 (6.4)	.138 (3.51)	
190190049	P-8139-032	190190050	P-8139-032T	190190056	PZ-8139-032	YELLOW	14-12	1.65-4.2	.187x.032 (4.75X0.81)	.016 (0.41)	.789 (20.04)	.43 (10.9)	.238 (6.05)	.125 (3.18)	.25 (6.4)	.170 (4.32)	
190190006	AA-8137	190190011	AA-8137T	190190018	AAZ-8137	RED	22-18	0.25-1.5	.187x.020 (4.75X0.51)	.016 (0.41)	.789 (20.04)	.43 (10.9)	.238 (6.05)	.125 (3.18)	.25 (6.4)	.115 (2.92)	
190190027	BB-8138	190190030	BB-8138T	190190079	BBZ-8138	BLUE	16-14	1.0-2.5	.187x.020 (4.75X0.51)	.016 (0.41)	.789 (20.04)	.43 (10.9)	.238 (6.05)	.125 (3.18)	.25 (6.4)	.138 (3.51)	
190190048	P-8139	190190051	P-8139T	190190055	PZ-8139	YELLOW	14-12	1.65-4.2	.187x.020 (4.75X0.51)	.016 (0.41)	.789 (20.04)	.43 (10.9)	.238 (6.05)	.125 (3.18)	.25 (6.4)	.170 (4.32)	
190190004	AA-8134	190190005	AA-8134T	190190075	AAZ-8134	RED	22-18	0.25-1.5	.110x.032 (2.80X0.81)	.012 (0.30)	.789 (20.04)	.43 (10.9)	.163 (4.14)	.210 (5.33)	.25 (6.4)	.115 (2.92)	
190190025	BB-8135	190190026	BB-8135T	190190078	BBZ-8135	BLUE	16-14	1.0-2.5	.110x.032 (2.80X0.81)	.012 (0.30)	.789 (20.04)	.43 (10.9)	.163 (4.14)	.210 (5.33)	.25 (6.4)	.138 (3.51)	
190190001	AA-8131	190190003	AA-8131T	190190017	AAZ-8131	RED	22-18	0.25-1.5	.110x.020 (2.80X0.81)	.012 (0.30)	.789 (20.04)	.43 (10.9)	.163 (4.14)	.210 (5.33)	.25 (6.4)	.115 (2.92)	
190190022	BB-8132	190190024	BB-8132T	190190076	BBZ-8132	BLUE	16-14	1.0-2.5	.110x.020 (2.80X0.81)	.012 (0.30)	.789 (20.04)	.43 (10.9)	.163 (4.14)	.210 (5.33)	.25 (6.4)	.138 (3.51)	

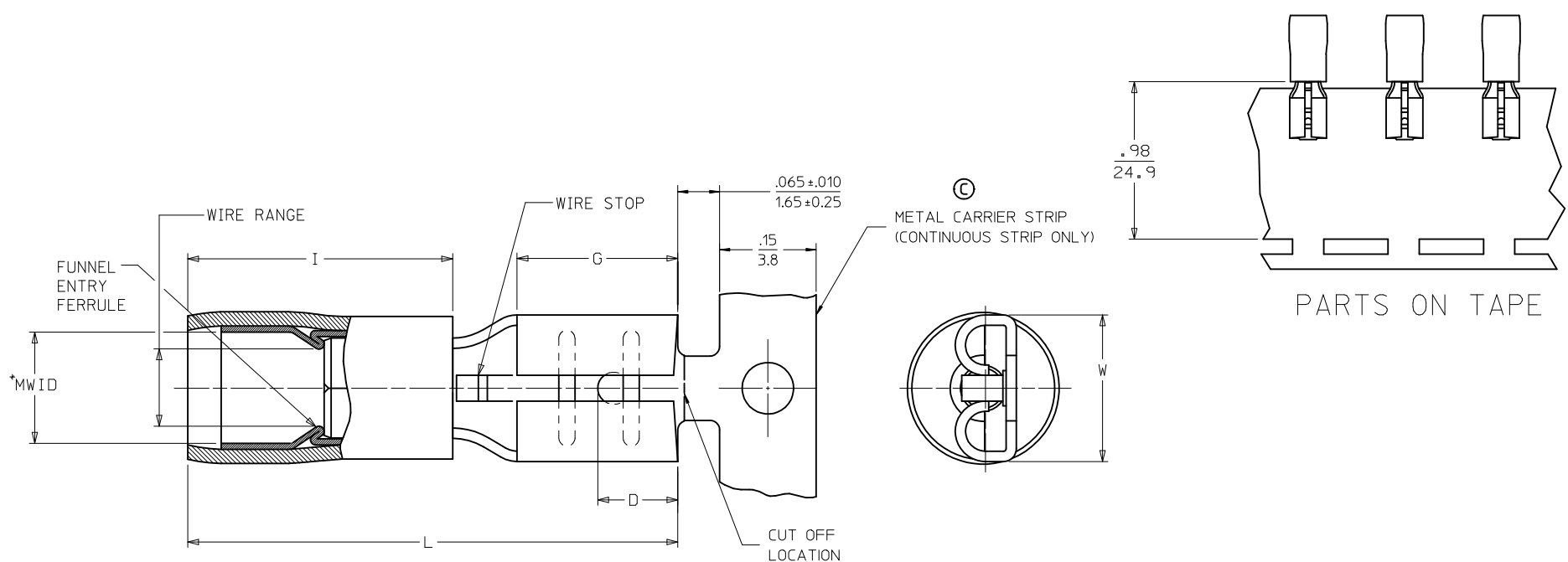

- NOTES:
1. MATERIAL: BRASS TERMINAL, COPPER ALLOY FERRULE
 2. FINISH: ELECTRO-TIN PLATING
 3. INSULATION: EXTRUDED NYLON
 - 4.*MWID=MAXIMUM WIRE INSULATION DIAMETER
 5. PARTS ARE ROHS COMPLIANT.

FERRULE DESCR. CONT P/N EC NO: MNA2009-0510 DRAWN:ETHRODAHL 2010/01/04 CHKD:JMACNEIL 2010/01/05 APPR:JMACNEIL 2010/01/05	QUALITY SYMBOLS ▽=0 ▽=0	GENERAL TOLERANCES (UNLESS SPECIFIED)		DIMENSION STYLE IN/MM		SCALE ---	DESIGN UNITS INCH	THIRD ANGLE PROJECTION	
		mm	INCH	DRAWN BY BRE	DATE 2001/07/25	TITLE QUICK DISCONNECT PARTIALLY INSULATED AVIKRIMP	MOLEX INCORPORATED		
4 PLACES ± --- ± ---		3 PLACES ± --- ± .005		CHECKED BY HEB		DATE 2001/07/25		APPROVED BY RWD	
2 PLACES ± 0.13 ± .01		1 PLACE ± 0.25 ± ---		DATE 2001/07/25		DOCUMENT NO. SD-19019-001		SHEET NO. 1 OF 1	
ANGULAR ± ---°		DRAFT WHERE APPLICABLE MUST REMAIN WITHIN DIMENSIONS		SEE CHART		THIS DRAWING CONTAINS INFORMATION THAT IS PROPRIETARY TO MOLEX INCORPORATED AND SHOULD NOT BE USED WITHOUT WRITTEN PERMISSION			