

10 9 8 7 6 5 4 3 2 1

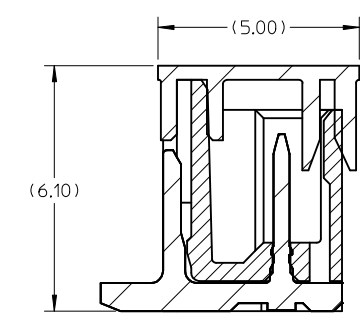
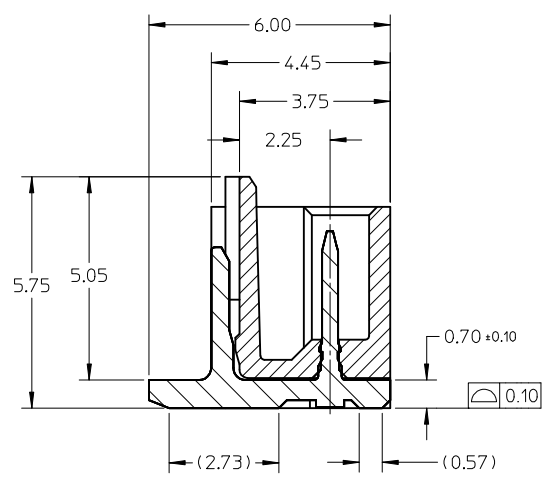
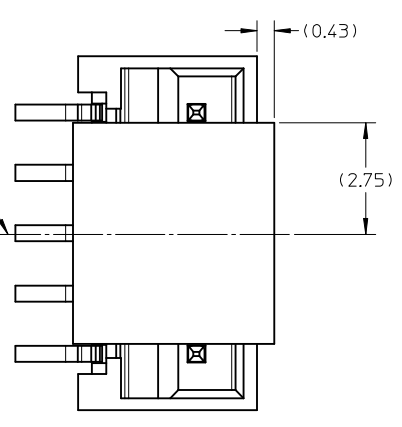
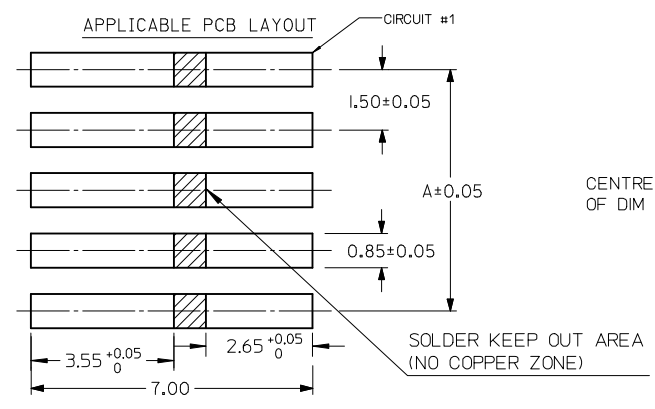
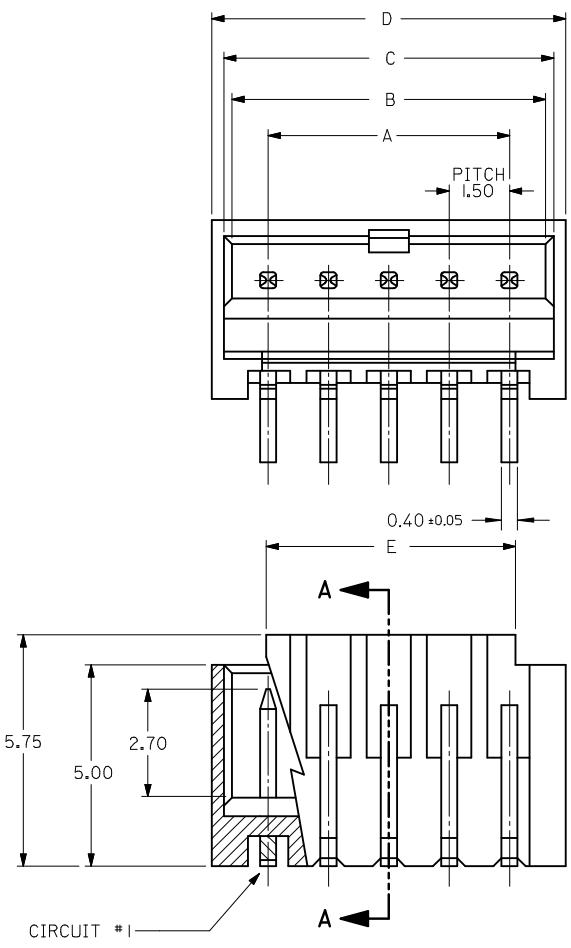

SECTION A-A
(WITHOUT CAP)

SECTION A-A
(WITH CAP)

- NOTES:
- MATERIAL:
HOUSING: NYLON, GLASS FILLED, UL94 V-0,
COLOR - SEE TABLE.
CAP: NYLON, GLASS FILLED, UL94V-0
COLOR: BEIGE.
PINS: BRASS ALLOY, C26000, P/N87437-8083.
 - PLATING: 2.54µM, MIN. TIN OVER 1.27µM MIN. NICKEL.
 - DRAWING SHOWS PLUG WITH 5 CIRCUITS.
 - HEADER TO BE USED WITH CRIMP HOUSING, P/N 87439
AND CRIMP TERMINAL, P/N 87421.
 - PARTS TO BE PACKED IN MOISTURE BAG.
 - THIS DRAWING IS RE-DRAWING OF SD-87437-**31.

REVISED EC NO: J2014-0799 DRW: HORI CHK: KASAKAWA APPR: NUKITA	2013/11/06 2013/11/07 2013/11/08	GENERAL TOLERANCES (UNLESS SPECIFIED)		DIMENSION STYLE MM ONLY		SCALE 8:1	DESIGN UNITS METRIC	THIRD ANGLE PROJECTION		
		10 UNDER	± 0.20	DRAWN BY TYAJIMA01	DATE 2013/09/19	TITLE 1.50MM PITCH, W-T-B HEADER, VERTICAL, SMT				
		10 OVER 30 UNDER	± 0.20	CHECKED BY KASAKAWA	DATE 2013/09/20					
		30 OVER	± 0.20	APPROVED BY NUKITA	DATE 2013/09/25					
ANGULAR ±3°		MATERIAL NO. SEE TABLE		DOCUMENT NO. SD-87437-001	SHEET NO. 1 OF 4					
DRAFT WHERE APPLICABLE MUST REMAIN WITHIN DIMENSIONS		SIZE A3	THIS DRAWING CONTAINS INFORMATION THAT IS PROPRIETARY TO MOLEX INCORPORATED AND SHOULD NOT BE USED WITHOUT WRITTEN PERMISSION							

9 8 7 6 5 4 3 2

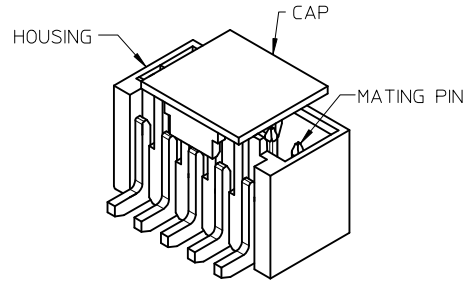

PART NUMBER ASSIGNMENT

87437-XXXX

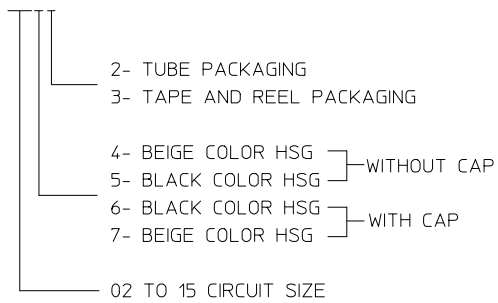

CIRCUIT SIZE	A	B	C	D	E
02	1.50	3.30	3.70	4.30	1.70
03	3.00	4.80	5.20	5.80	3.20
04	4.50	6.30	6.70	7.30	4.70
05	6.00	7.80	8.20	8.80	6.20
06	7.50	9.30	9.70	10.30	7.70
07	9.00	10.80	11.20	11.80	9.20
08	10.50	12.30	12.70	13.30	10.70
09	12.00	13.80	14.20	14.80	12.20
10	13.50	15.30	15.70	16.30	13.70
11	15.00	16.80	17.20	17.80	15.20
12	16.50	18.30	18.70	19.30	16.70
13	18.00	19.80	20.20	20.80	18.20
14	19.50	21.30	21.70	22.30	19.70
15	21.00	22.80	23.20	23.80	21.20

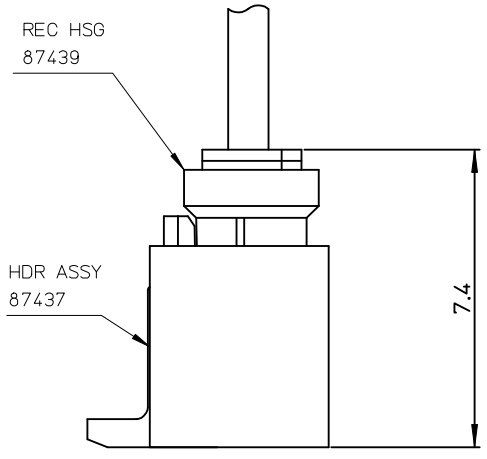

嵌合状態図
MATED CONNECTORS

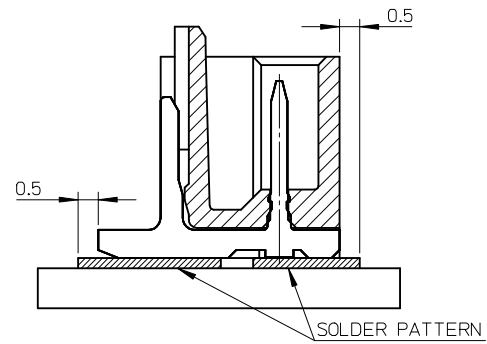

MOUNTING POSITION OF THE CONNECTOR

REVISED EC NO: J2014-0799 TDR: WAKAHORI CHKD: KASAKAWA APPR: NUKITA	2013/11/06 2013/11/07 2013/11/08	GENERAL TOLERANCES (UNLESS SPECIFIED)		DIMENSION STYLE MM ONLY		SCALE 8:1	DESIGN UNITS METRIC	THIRD ANGLE PROJECTION
	DESCRIPTION	10 UNDER	± 0.20	DRAWN BY	DATE	TITLE 1.50MM PITCH, W-T-B HEADER, VERTICAL, SMT molex DOCUMENT NO. SD-87437-001 SHEET NO. 2 OF 4		
		10 OVER 30 UNDER	± 0.20	CHECKED BY	DATE			
		30 OVER	± 0.20	APPROVED BY	DATE			
	ANGULAR	± 3 °	DRAFT WHERE APPLICABLE MUST REMAIN WITHIN DIMENSIONS		MATERIAL NO.	SEE TABLE		
					SIZE A3	THIS DRAWING CONTAINS INFORMATION THAT IS PROPRIETARY TO MOLEX INCORPORATED AND SHOULD NOT BE USED WITHOUT WRITTEN PERMISSION		

10 9 8 7 6 5 4 3 2 1

EMBOSSED CARRIER TAPE PACKING DETAILS FOR PARTS WITHOUT CAP

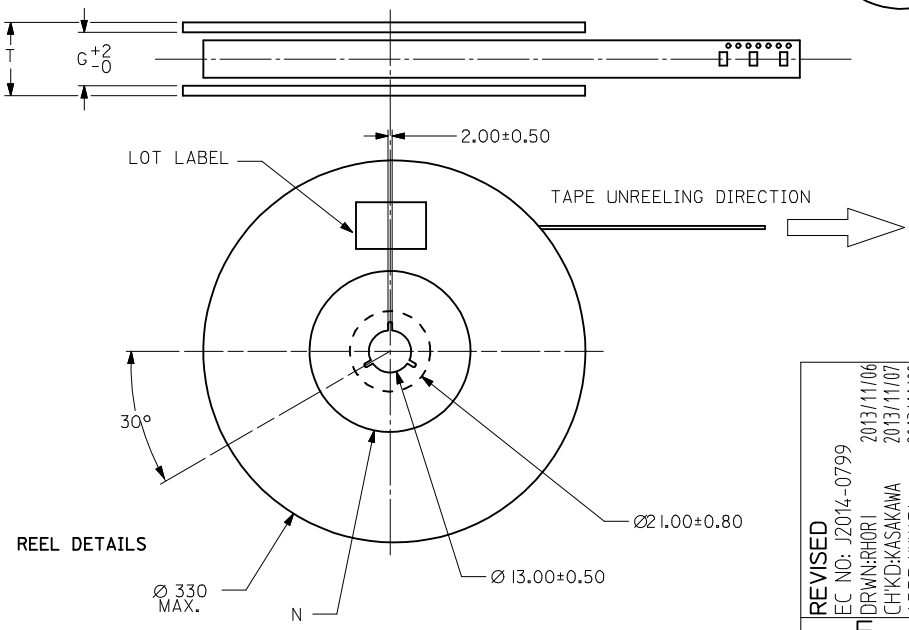
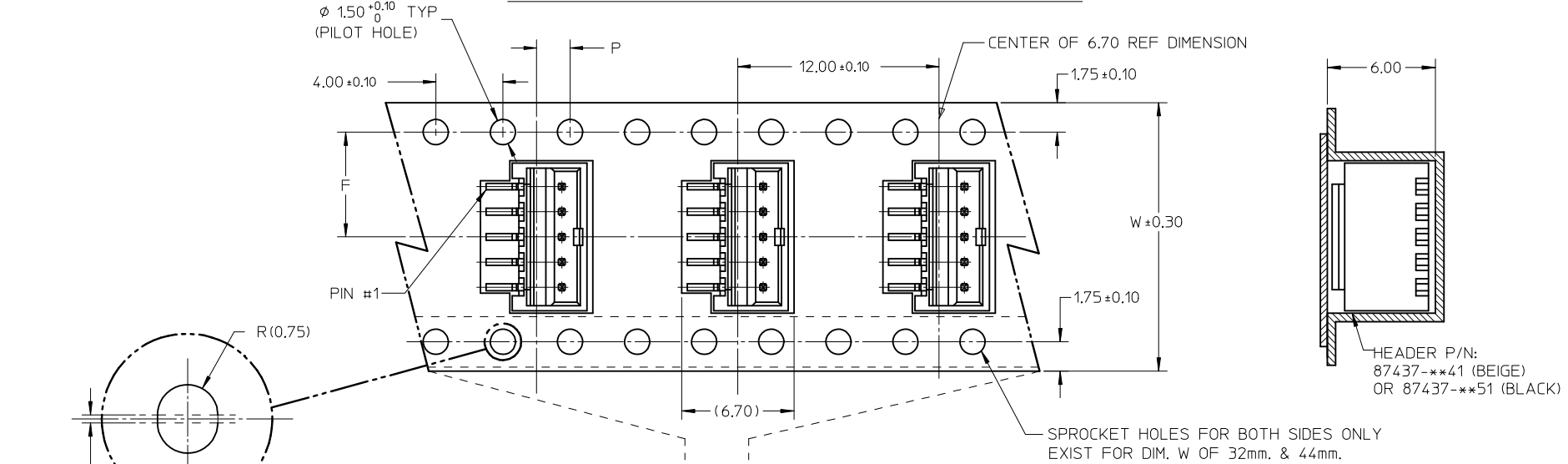

REVISED EC NO: J2014-0799 DRW:RHORI 2013/11/06 CHKD:KASAKAWA 2013/11/07 APPR:NUKITA 2013/11/08	GENERAL TOLERANCES (UNLESS SPECIFIED)		DIMENSION STYLE MM ONLY		SCALE 8:1	DESIGN UNITS METRIC	THIRD ANGLE PROJECTION
	10 UNDER	± 0.20	DRAWN BY TYAJIMA01	DATE 2013/09/19	TITLE 1.50MM PITCH, W-T-B HEADER, VERTICAL, SMT		
	10 OVER 30 UNDER	± 0.20	CHECKED BY KASAKAWA	DATE 2013/09/20	APPROVED BY NUKITA 2013/09/25		
	30 OVER	± 0.20	MATERIAL NO. SEE TABLE		DOCUMENT NO. SD-87437-001	SHEET NO. 3 OF 4	
ANGULAR ± 3 °		THIS DRAWING CONTAINS INFORMATION THAT IS PROPRIETARY TO MOLEX INCORPORATED AND SHOULD NOT BE USED WITHOUT WRITTEN PERMISSION					
DRAFT WHERE APPLICABLE MUST REMAIN WITHIN DIMENSIONS							

9 8 7 6 5 4 3 2 1

EMBOSSED CARRIER TAPE PACKING DETAILS FOR PARTS WITH CAP

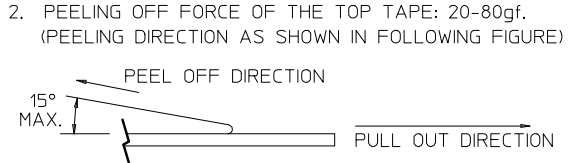
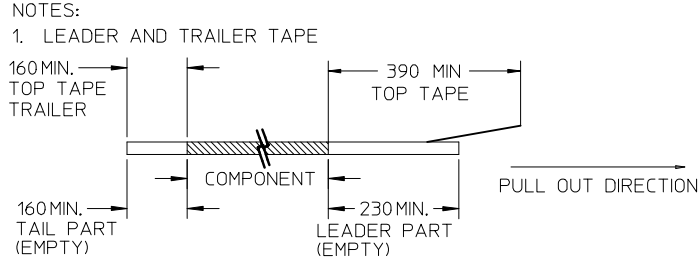
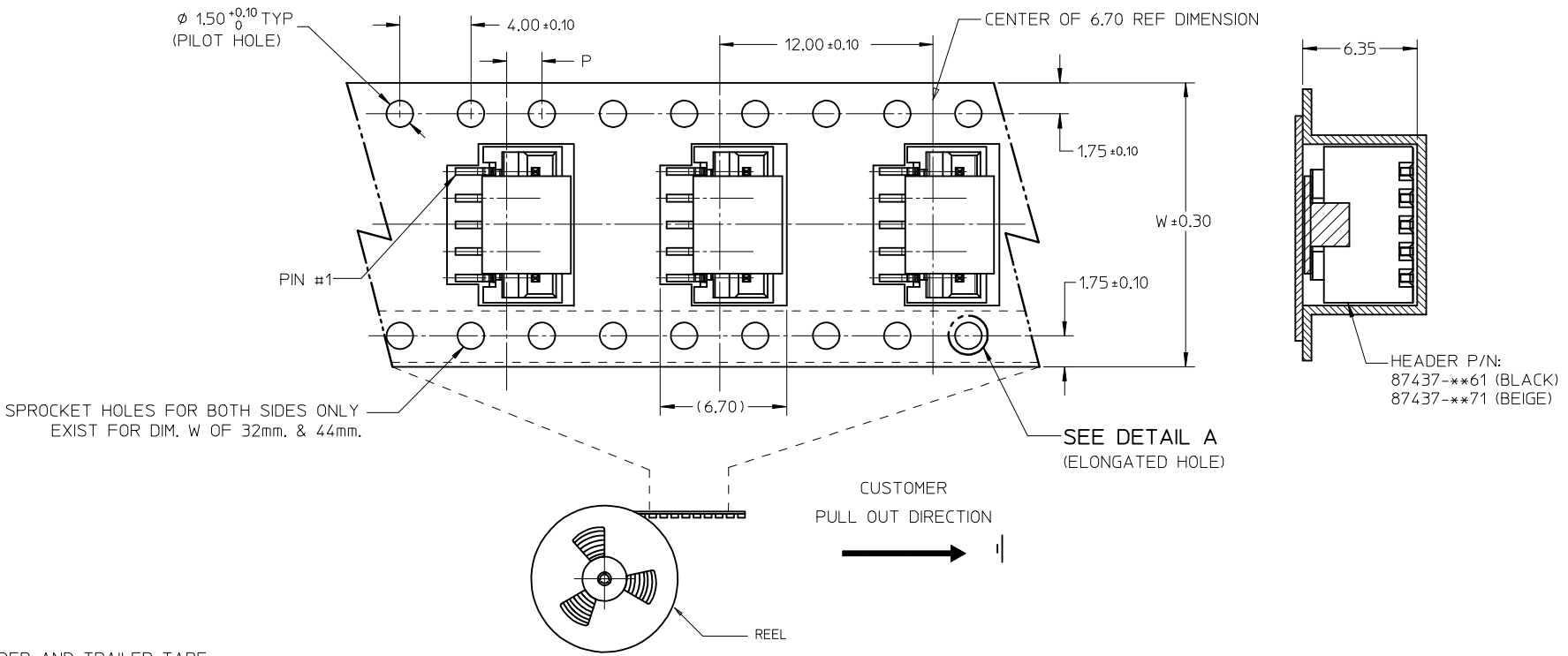

- THE TAPE IS TREATED FOR ANTI-STATIC.
- PACKAGING STANDARD IS AS PER EIA-481.
- TAPE & REEL QUANTITY = 1000PCS/REEL (WITHOUT CAP)
TAPE & REEL QUANTITY = 900PCS/REEL (WITH CAP)

15	44	20.20±0.15	100	44.40	50.40	2.00±0.15
11, 12, 13, 14	32	14.20±0.10	100	32.40	38.40	2.00±0.10
7, 8, 9, 10	24	11.50±0.10	100	24.40	30.40	2.00±0.10
2, 3, 4, 5, 6	16	7.50±0.10	100	16.40	22.40	2.00±0.10
CIRCUIT SIZE	W	F	N	G	T MAX	P

REVISED EC NO: J2014-0799 TDRWNRHORI 2013/11/06 CHKD:KASAKAWA 2013/11/07 APPR:NUKITA 2013/11/08	DESCRIPTION GENERAL TOLERANCES (UNLESS SPECIFIED) 10 UNDER ±0.20 10 OVER 30 UNDER ±0.20 30 OVER ±0.20 ANGULAR ±3 ° DRAFT WHERE APPLICABLE MUST REMAIN WITHIN DIMENSIONS	DIMENSION STYLE MM ONLY	SCALE 8:1	DESIGN UNITS METRIC	THIRD ANGLE PROJECTION		
		DRAWN BY TYAJIMA01	DATE 2013/09/19	TITLE 1.50MM PITCH, W-T-B HEADER, VERTICAL, SMT			
		CHECKED BY KASAKAWA	DATE 2013/09/20	APPROVED BY NUKITA			
		DATE 2013/09/25	MATERIAL NO. SEE TABLE	DOCUMENT NO. SD-87437-001	SHEET NO. 4 OF 4		

THIS DRAWING CONTAINS INFORMATION THAT IS PROPRIETARY TO MOLEX INCORPORATED AND SHOULD NOT BE USED WITHOUT WRITTEN PERMISSION