

10 9 8 7 6 5 4 3 2 1

F
E
D
C
B
A

F
E
D
C
B
A

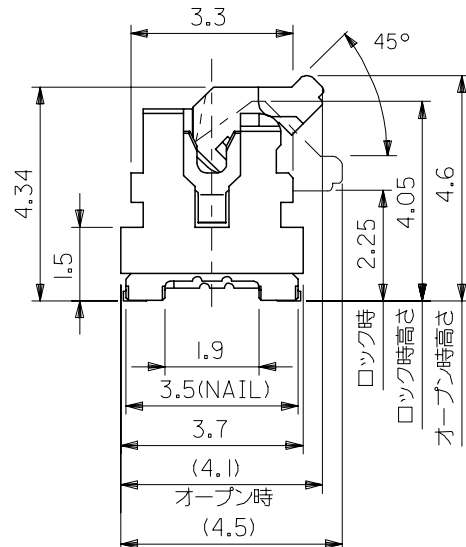
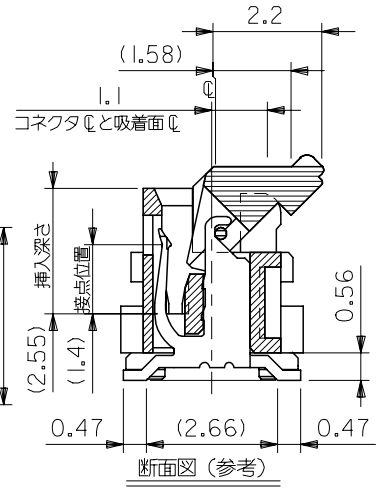
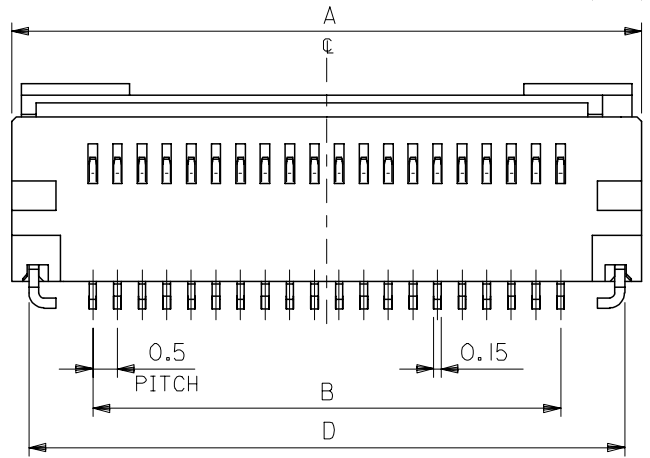
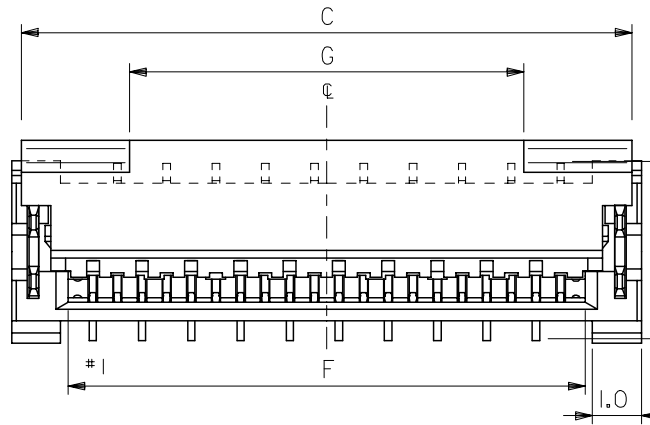

注記
NOTES:

1. 材質
MATERIAL
ハウジング: LCP (液晶ポリマー)、ガラス充填、白色、UL94V-0
HOUSING: LCP (LIQUID CRYSTAL POLYMER), GLASS FILLED, WHITE, UL94V-0
アクチュエータ: PPS、ガラス充填、茶色、UL94V-0
ACTUATOR: PPS (POLYPHENYLENE SULFIDE), GLASS FILLED, BROWN, UL94V-0
ターミナル: 銅合金 (t=0.15)
TERMINAL: COPPER ALLOY (t=0.15)
金具: 銅合金 (t=0.2)
NAIL: COPPER ALLOY (t=0.2)
2. メッキ仕様
PLATING
ターミナル
TERMINAL
接点部: 金メッキ 0.1μm 以上
CONTACT AREA: Au PLATING 0.1 MICROMETER MINIMUM.
テール部: 錫メッキ 1.0μm 以上
TAIL AREA: TIN PLATING 1.0 MICROMETER MINIMUM.
下地メッキ: ニッケルメッキ 1.0μm 以上
UNDER PLATING: NICKEL PLATING 1.0 MICROMETER MINIMUM.
3. テールと金具を併せた平坦度は、0.1ミリアール以下。
TAILS AND NAILS COPLANARITY TO BE 0.1 MICROMETER MAXIMUM.

8	30.5	30.7	32.1	32.4	29.5	32.8	51374-6028	60
8	25.5	25.7	27.1	27.4	24.5	27.8	51374-5028	50
8	23.0	23.2	24.6	24.9	22.0	25.3	51374-4528	45
8	20.5	20.7	22.1	22.4	19.5	22.8	51374-4028	40
8	15.5	15.7	17.1	17.4	14.5	17.8	51374-3028	30
8	12.5	12.7	14.1	14.4	11.5	14.8	51374-2428	24
4.5	5.5	5.7	7.1	7.4	4.5	7.8	51374-1028	10
G	F	E	D	C	B	A	MATERIAL NO.	CIRCUITS

REVISED EC NO: J2006-2397 DRW: NAIDA 2006/01/27 CHK: KTOYODA 2006/01/31 APP: NUKITA 2006/02/02	GENERAL TOLERANCES (UNLESS SPECIFIED)		DIMENSION STYLE MM ONLY		SCALE 10:1	DESIGN UNITS METRIC	THIRD ANGLE PROJECTION	
	10 UNDER	±0.2	DRAWN BY M. NABEI	DATE '05/07/15	TITLE 0.5 FPC CONN. HS'G ASS'Y EASY ON / STRAIGHT -LEAD FREE-			
	10 OVER 30 UNDER	±0.25	CHECKED BY K. TOYODA	DATE '05/07/15				
	30 OVER	±0.3	APPROVED BY N. UKITA	DATE '05/07/15				
	ANGULAR ±3 °		MATERIAL NO. SEE CHART		DOCUMENT NO. SD-51374-026		SHEET NO. 1 OF 2	
DRAFT WHERE APPLICABLE MUST REMAIN WITHIN DIMENSIONS		SIZE A3		THIS DRAWING CONTAINS INFORMATION THAT IS PROPRIETARY TO MOLEX INCORPORATED AND SHOULD NOT BE USED WITHOUT WRITTEN PERMISSION				

10 9 8 7 6 5 4 3 2 1

F

E

D

C

B

A

F

E

D

C

B

A

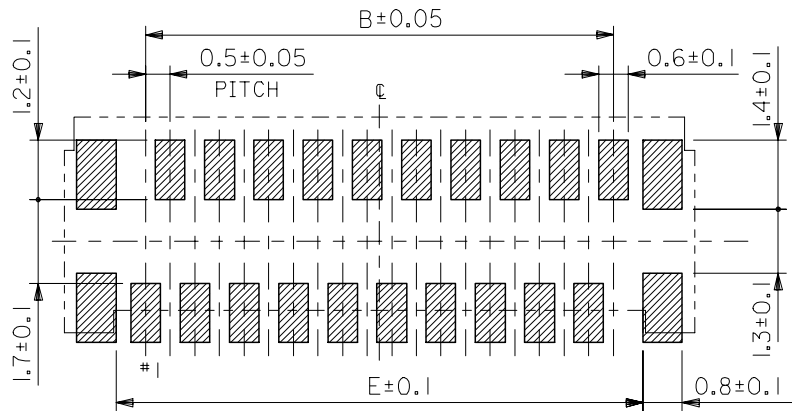

参考基板レイアウト (マウント面)
P.C. BOARD PATTERN DIMENSION (REF.)
(MOUNT AREA)

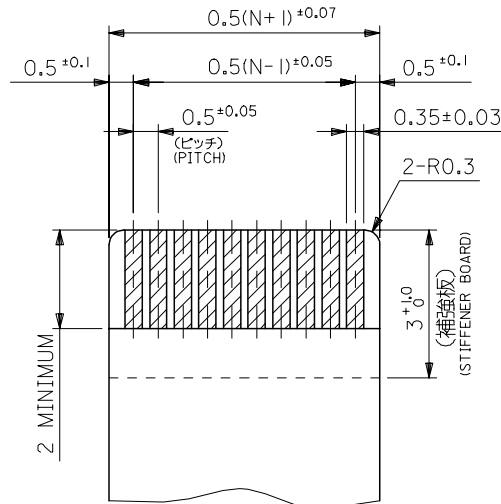

適合FPC推奨寸法
APPLICABLE FPC
RECOMMENDED DIMENSION
(仕上がり厚さ: 0.3 ± 0.05)
(THICKNESS: 0.3 ± 0.05)

N: 極数
N: CIRCUITS

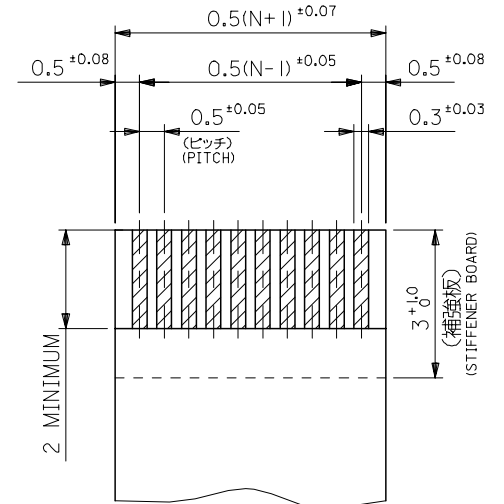

適合FFC推奨寸法
APPLICABLE FFC
RECOMMENDED DIMENSION
(仕上がり厚さ: 0.3 ± 0.05)
(THICKNESS: 0.3 ± 0.05)

N: 極数
N: CIRCUITS

FPC/FFCについて:

打抜き方向は導体側から補強板側を推奨いたします。
導体部については軟銅箔35マイクロメートルまたは50マイクロメートル

ABOUT FPC/FFC

RECOMMENDED PUNCHER DIRECTION : FROM CONDUCTOR SIDE TO STIFFENER FILM SIDE.
RECOMMENDED CONDUCTOR SPEC :
THICKNESS OF SOFT COPPER FOIL : 35 MICROMETER OR 50 MICROMETER

FPCについて:

補強フィルム材質はポリイミドを推奨します。
接着剤は熱硬化接着剤を推奨します。

ABOUT FPC

RECOMMENDED MATERIAL :
STIFFENER FILM : POLYIMIDE
BONDING AGENT : THERMOSETTING BONDING AGENT

REVISED EC NO: J2006-2397 DRW:NAIDA 2006/01/27 CHK:KTOYODA 2006/01/31 APPR:NUKITA 2006/02/02	GENERAL TOLERANCES (UNLESS SPECIFIED)		DIMENSION STYLE MM ONLY		SCALE 10:1	DESIGN UNITS METRIC	THIRD ANGLE PROJECTION		
	10 UNDER	± 0.2	DRAWN BY M. NABEI	DATE '05/07/15	TITLE 0.5 FPC CONN. HS'G ASS'Y EASY ON / STRAIGHT -LEAD FREE-				
	10 OVER 30 UNDER	± 0.25	CHECKED BY K. TOYODA	DATE '05/07/15					
	30 OVER	± 0.3	APPROVED BY N. UKITA	DATE '05/07/15	MOLEX INCORPORATED				
ANGULAR	± 3 °	MATERIAL NO.	DOCUMENT NO. SD-51374-026	SHEET NO. 2 OF 2					
DRAFT WHERE APPLICABLE MUST REMAIN WITHIN DIMENSIONS		SIZE A3	THIS DRAWING CONTAINS INFORMATION THAT IS PROPRIETARY TO MOLEX INCORPORATED AND SHOULD NOT BE USED WITHOUT WRITTEN PERMISSION						

注)
NOTES

1. 製品番号 51374-**28 詳細寸法については、製品単体図面を参照下さい。
IN THE PACKAGE PART NUMBER 51374-**28 DETAILED DIMENSIONS, SEE SALES DRAWING FOR CONNECTOR.
2. 梱包数量：2000個/リール
NUMBER OF CONNECTORS:2000 PCS/REEL.
3. リードテープ長さ
LEAD TAPE LENGTH

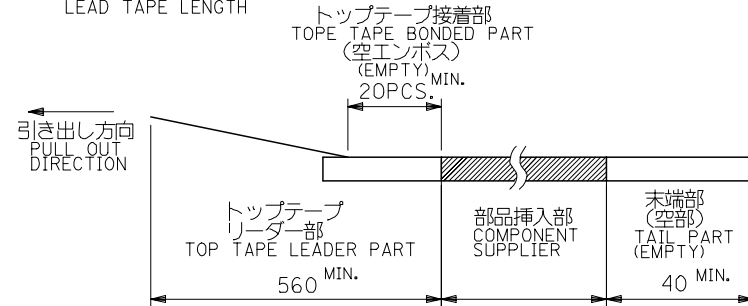
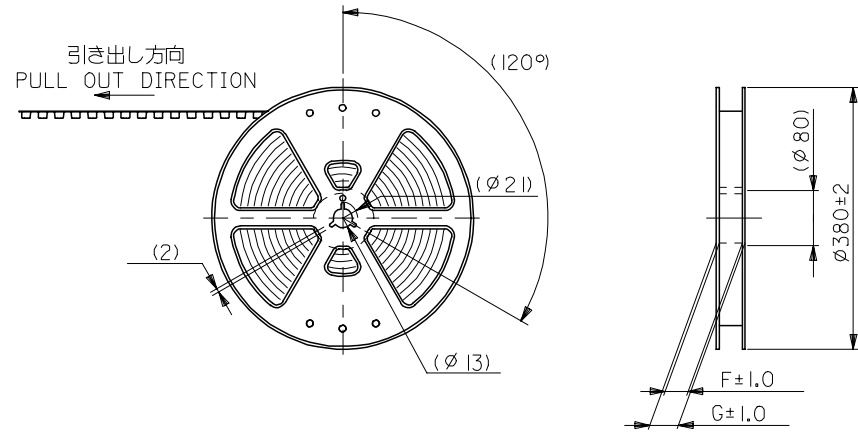

4. トップテープの剥離強度：(剥離方向は下図参照)
PEELING OFF FORCE OF TOP TAPE (PELLING DIRECTION AS SHOWN IN FOLLOWING FIGURE.)
0. 1~1. 3N{ 10~130gf }

尚、本規格値は、出荷時に適用。
THIS REQUIREMENT SHOULD BE APPLIED AT SHIPMENT.
(但し、輸送時に剥離が発生しない事。)
(PEEL OFF SHOULD NOT BE ALLOWED, DURING TRANSPORTATION.)

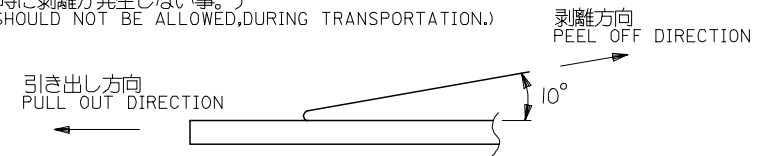

5. 材料
MATERIAL
キャリアテープ：ポリプロピレン (PP)
CARRIER TAPE: POLYPROPYLENE (PP)
トップテープ：PET, PE, PEF
TOP TAPE: PET, PE, PEF
リール：ポリスチレン
REEL : POLYSTYRENE

MODEL NO. 51374-**72

REVISED EC NO: J2006-2397 DRW: NAITA 2006/01/27 CHK: KTOYODA 2006/01/31 APP: NUKITA 2006/02/02	GENERAL TOLERANCES (UNLESS SPECIFIED)		DIMENSION STYLE MM ONLY		SCALE ---	DESIGN UNITS METRIC	THIRD ANGLE PROJECTION	
	10 UNDER	±0.2	DRAWN BY M. NABEI	DATE '05/07/15	TITLE 51374-**28 TAPING PACKAGE -LEAD FREE-			
	10 OVER 30 UNDER	±0.25	CHECKED BY K. TOYODA	DATE '05/07/15	MOLEX INCORPORATED			
	30 OVER	±0.3	APPROVED BY N. UKITA	DATE '05/07/15				
	ANGULAR	±3 °	MATERIAL NO.		DOCUMENT NO.	SHEET NO.		
DRAFT WHERE APPLICABLE MUST REMAIN WITHIN DIMENSIONS		SEE SHEET 2 OF 2		SD-51374-027		1 OF 2		

10 9 8 7 6 5 4 3 2 1

F
E
D
C
B
A

F
E
D
C
B
A

引き出し方向
PULL OUT DIRECTION

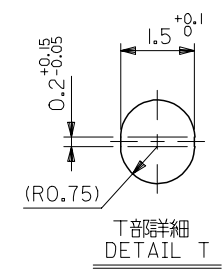
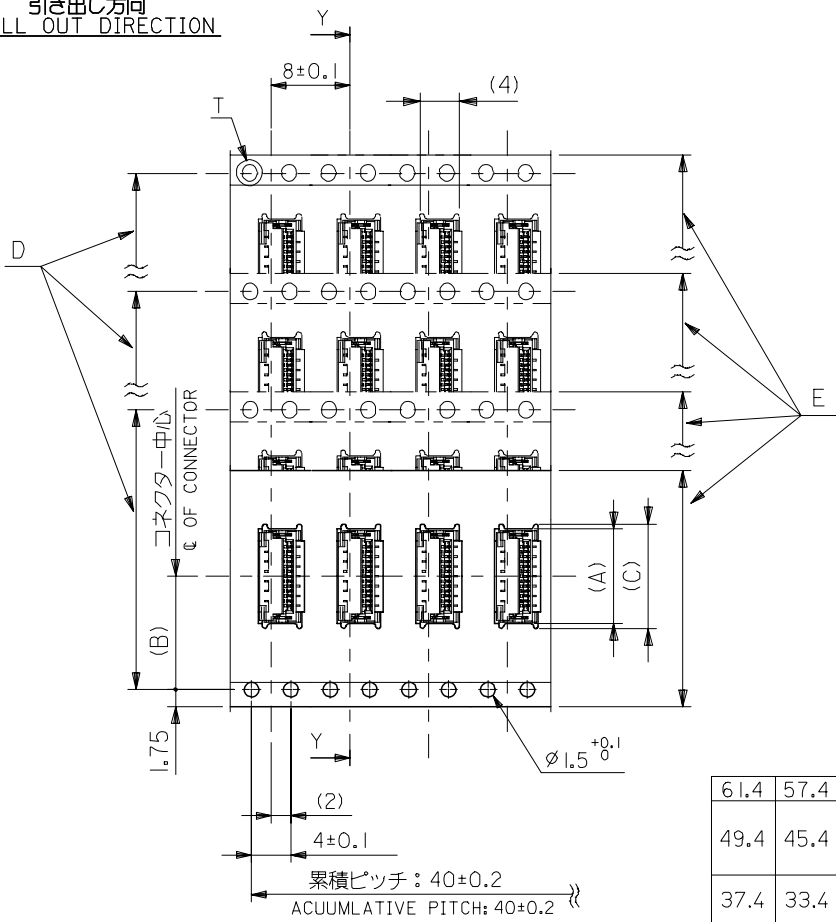
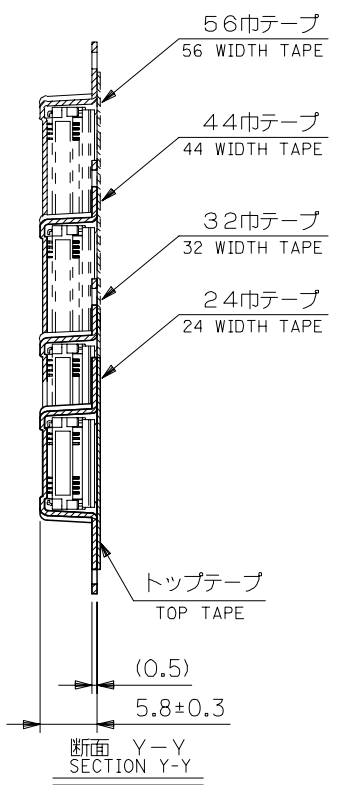

61.4	57.4	56±0.3	52.4	34.1	26.2	33.1	51374-6072	60
				29.1		28.1	51374-5072	50
49.4	45.4	44±0.3	40.4	26.6	20.2	25.6	51374-4572	45
				24.1		23.1	51374-4072	40
37.4	33.4	32±0.3	28.4	19.1	14.2	18.1	51374-3072	30
				16.1		15.1	51374-2472	24
29.4	25.4	24±0.3		9.1	11.5	8.1	51374-1072	10
G	F	E キャリアテープ幅 CARRIER TAPE WIDTH	D	(C)	(B)	(A)	製品番号 MATERIAL NO.	極数 CIRCUITS

REVISED EC NO: J2006-2397 DRW:NAIDA 2006/01/27 CHK:K:TOYODA 2006/01/31 APPR:NUKITA 2006/02/02 REV B	GENERAL TOLERANCES (UNLESS SPECIFIED)		DIMENSION STYLE MM ONLY		SCALE ---	DESIGN UNITS METRIC	THIRD ANGLE PROJECTION	
	10 UNDER	±0.2	DRAWN BY M. NABEI		DATE '05/07/15		TITLE 51374-**28 TAPING PACKAGE -LEAD FREE-	
	10 OVER 30 UNDER	±0.25	CHECKED BY K. TOYODA		DATE '05/07/15		MOLEX INCORPORATED	
	30 OVER	±0.3	APPROVED BY N. UKITA		DATE '05/07/15		DOCUMENT NO. SD-51374-027	
	ANGULAR	±1 °	MATERIAL NO. SEE CHART		SHEET NO. 2 OF 2			
DRAFT WHERE APPLICABLE MUST REMAIN WITHIN DIMENSIONS			SIZE A3		THIS DRAWING CONTAINS INFORMATION THAT IS PROPRIETARY TO MOLEX INCORPORATED AND SHOULD NOT BE USED WITHOUT WRITTEN PERMISSION			