

NOTES

- 54132\*\*22 のアクチュエータはハウジング内に押し下げた状態とする。  
詳細寸法については図面 54132100(Doc. Part No.: 000) をご参照下さい。  
ACTUATOR OF PART NO. 54132\*\*22 SHOULD BE LOCKED .  
BE DETAILED DIMENSIONS, SEE 54132100(Doc. Part No.: 000)
- 梱包数量 : 1500個 / リール  
NUMBER OF CONNECTORS : 1500 PCS/REEL.
- リードテープ長さ LEAD TAPE LENGTH.

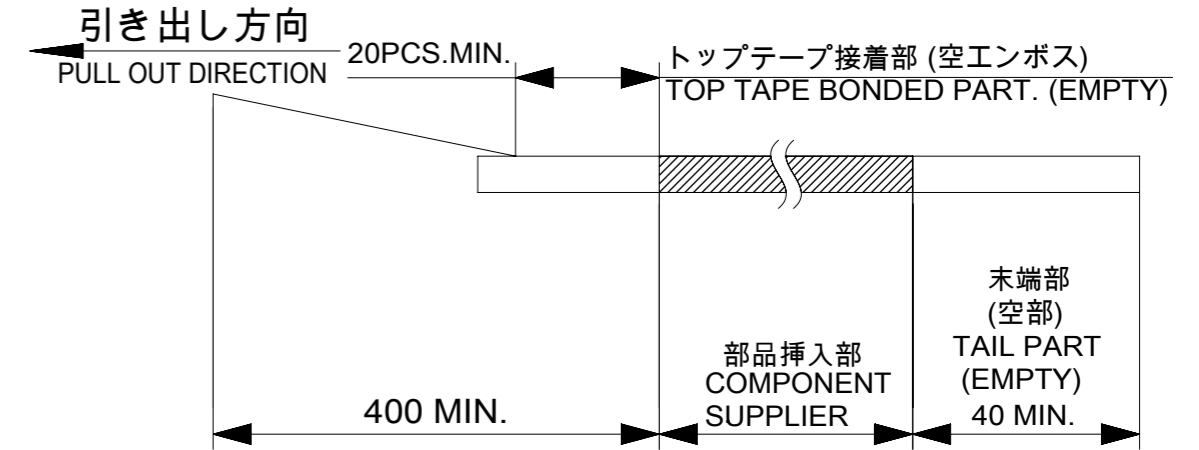

- カバートープの剥離強度については、IEC60286-3に準拠  
COVER TAPE PEEL FORCE IS DEDFINED BY IEC 60286-3
- 材料 ( MATERIAL )  
キャリアテープ ( CARRIER TAPE ) : ポリスチレン(PS) ( POLYSTYRENE )  
トップテープ ( TOP TAPE ) : PS  
リール ( REEL ) : ポリスチレン ( POLYSTYLENE )
- ELV及びRoHS適合品  
ELV AND RoHS COMPLIANT.

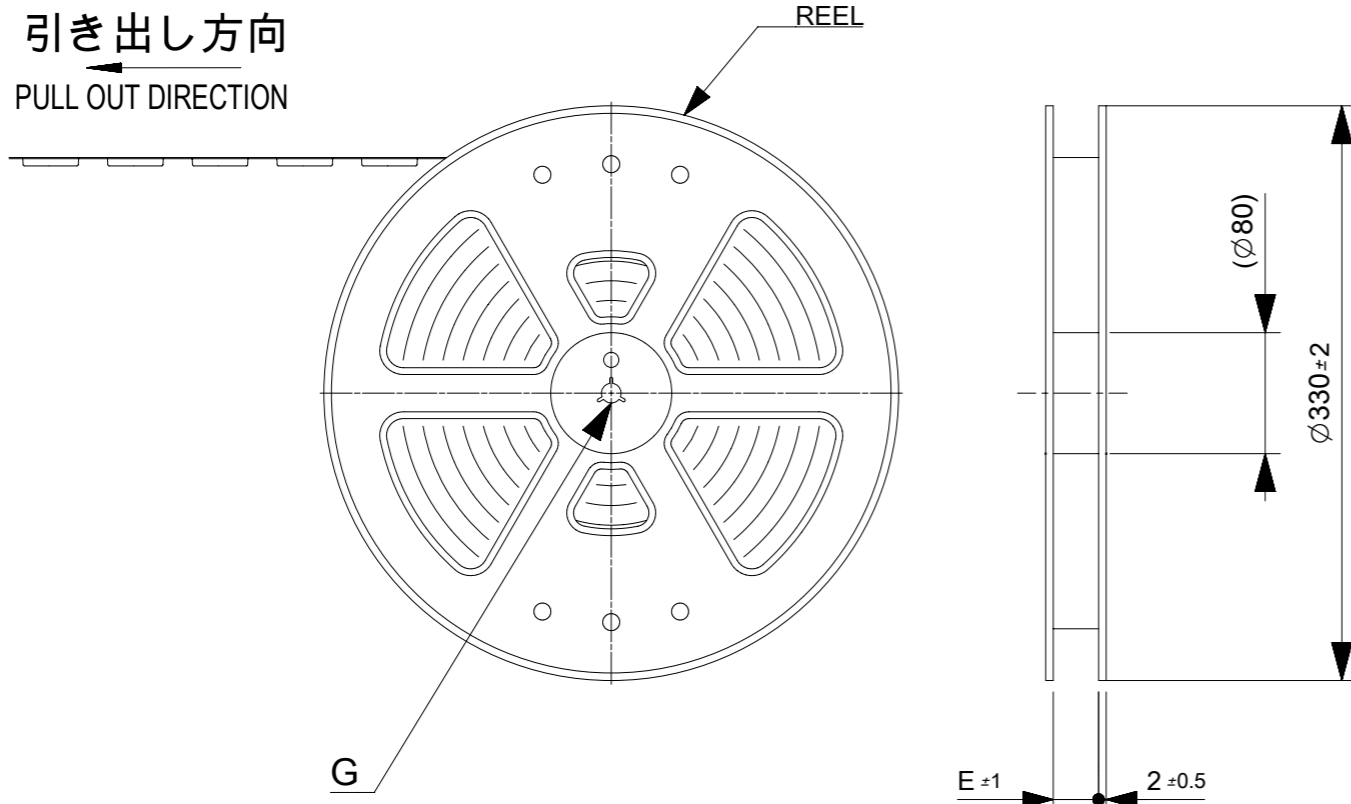
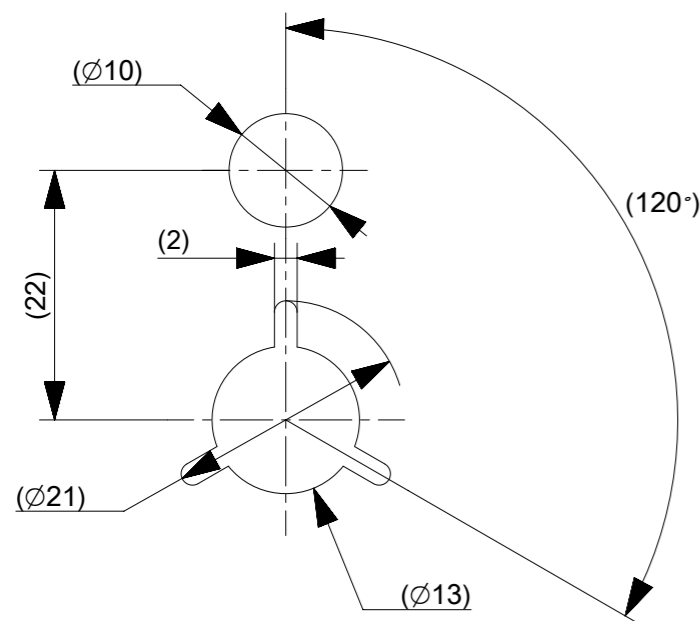

DETAIL G

PRE-RELEASE  
REFERENCE  
USE ONLY

THIS DRAWING CONTAINS INFORMATION THAT IS PROPRIETARY TO MOLEX ELECTRONIC TECHNOLOGIES, LLC AND SHOULD NOT BE USED WITHOUT WRITTEN PERMISSION

EC NO: 103444 DRWN: NVELUSAMY CHK'D: YKOBAYASHI02 APPR:	2016/02/18 2016/05/23	GENERAL TOLERANCES (UNLESS SPECIFIED)		DIMENSION UNITS MM	SCALE 1:1					
	ANGULAR TOL ± °		DRWN BY NVELUSAMY		DATE 2016/02/18					EMBOSSSED TAPE PACKAGED FOR 0.5MM FPC CONN ZIF R/A HOUSING ASSY
	4 PLACES ±		CHK'D BY YKOBAYASHI02		DATE 2016/05/23	PRODUCT CUSTOMER DRAWING				
	3 PLACES ±		APPR BY		DATE					SERIES 54132
2 PLACES ±		DRAFT WHERE APPLICABLE MUST REMAIN WITHIN DIMENSIONS		DRAWING SIZE A3	THIRD ANGLE PROJECTION		DOCUMENT NUMBER 541320000	DOC TYPE PSD	DOC PART 000	SHEET NUMBER 1 OF 2
1 PLACE ±										
0 PLACES ±										

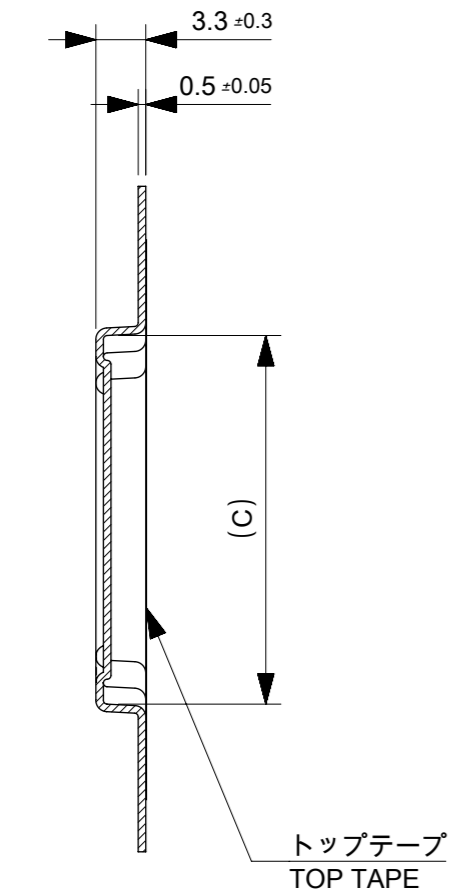

SECTION Y-Y

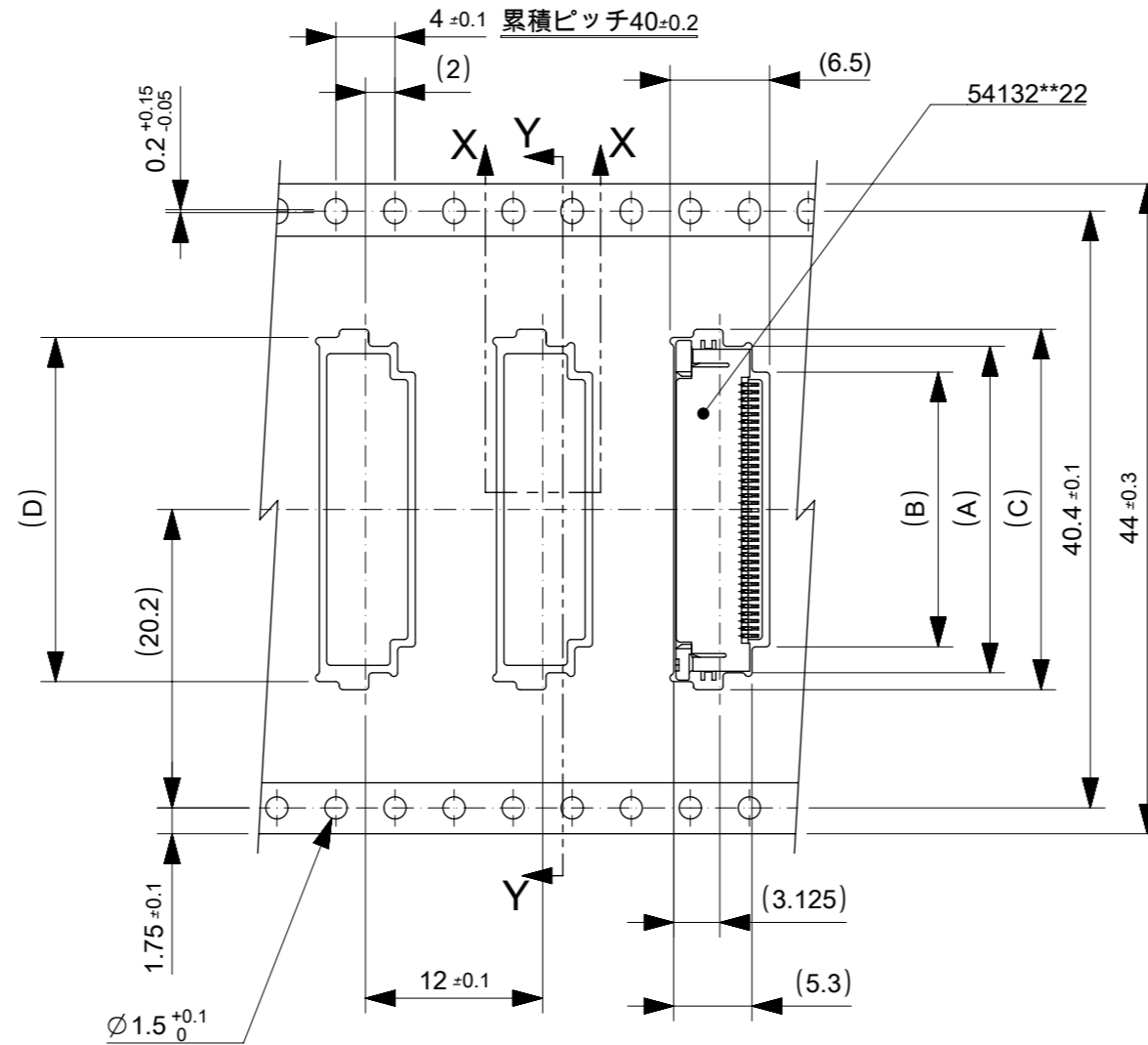

引き出し方向

PRE-RELEASE  
REFERENCE  
USE ONLY

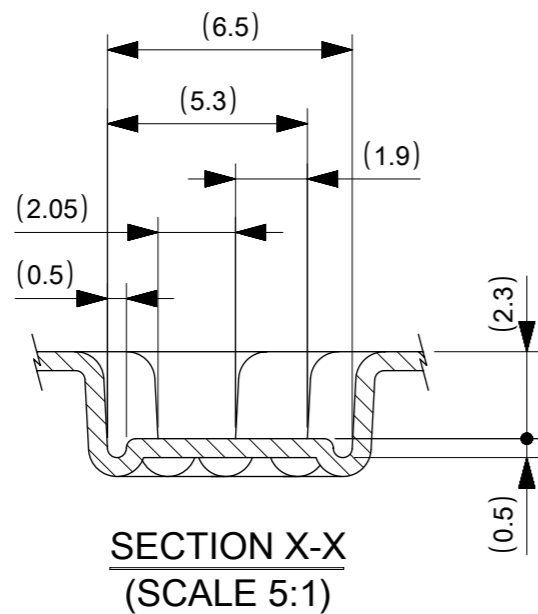

SECTION X-X  
(SCALE 5:1)

44	45.5	30.8	31.9	26.1	29.6	541325033	50	
		28.3	29.4	23.6	27.1	541324533	45	
		27.3	28.4	22.6	26.1	541324333	43	
		25.8	26.9	21.1	24.6	541324033	40	
		24.8	25.9	20.1	23.6	541323833	38	
		23.8	24.9	19.1	22.6	541323633	36	
		23.3	24.4	18.6	22.1	541323533	35	
		22.8	23.9	18.1	21.6	541323433	34	
		22.3	23.4	17.6	21.1	541323333	33	
		21.8	22.9	17.1	20.6	541323233	32	
		20.8	21.9	16.1	19.6	541323033	30	
キャリアテープ幅 CARRIER TAPE WIDTH		E	D	C	B	A	MATERIAL NO.	CKT.

THIS DRAWING CONTAINS INFORMATION THAT IS PROPRIETARY TO MOLEX ELECTRONIC TECHNOLOGIES, LLC AND SHOULD NOT BE USED WITHOUT WRITTEN PERMISSION

EC NO: 103444 DRWN: NVELUSAMY CHK'D: YKOBAYASHI02 APPR:	2016/02/18	GENERAL TOLERANCES (UNLESS SPECIFIED)		DIMENSION UNITS	SCALE
	2016/05/23	ANGULAR TOL ± °		MM	1:1
		4 PLACES ±		DRWN BY	DATE
		3 PLACES ±		NVELUSAMY	2016/02/18
		2 PLACES ±		CHK'D BY	DATE
	1 PLACE ±		YKOBAYASHI02	2016/05/23	
	0 PLACES ±		APPR BY	DATE	
DRAFT WHERE APPLICABLE MUST REMAIN WITHIN DIMENSIONS		DRAWING SIZE	THIRD ANGLE PROJECTION		
A	REV	A3			

<b>molex</b>			
EMBOSSSED TAPE PACKAGED FOR 0.5MM FPC CONN ZIF R/A HOUSING ASSY			
PRODUCT CUSTOMER DRAWING			
SERIES	MATERIAL NUMBER	CUSTOMER	
54132	SEE CHART	GENERAL	
DOCUMENT NUMBER		DOC TYPE	DOC PART
541320000		PSD	000
SHEET NUMBER		2 OF 2	

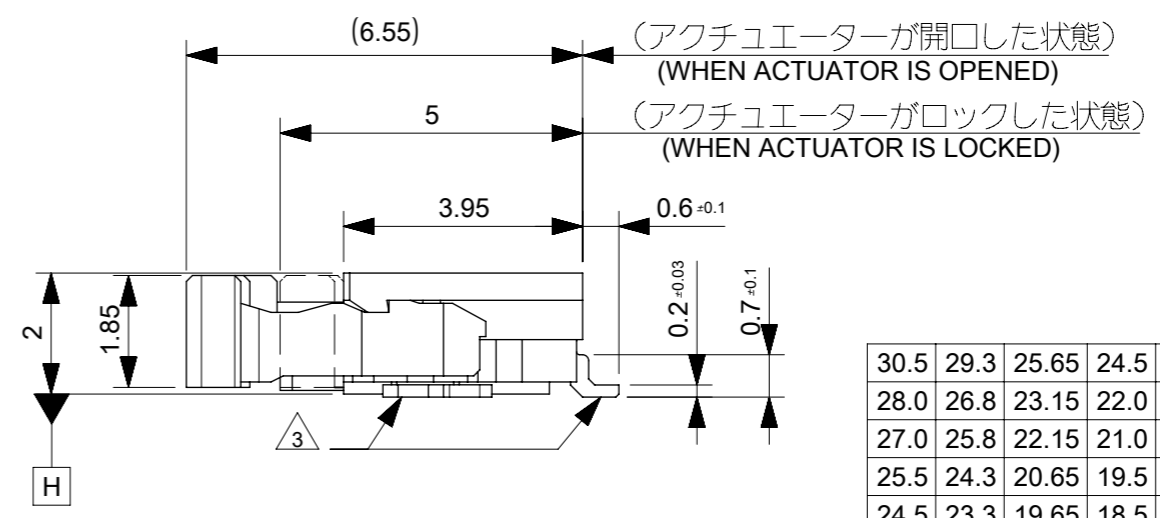
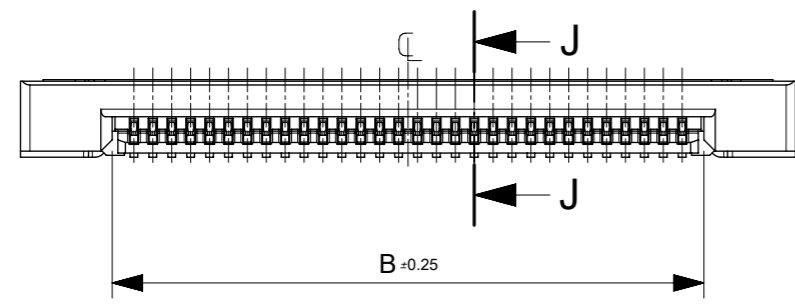
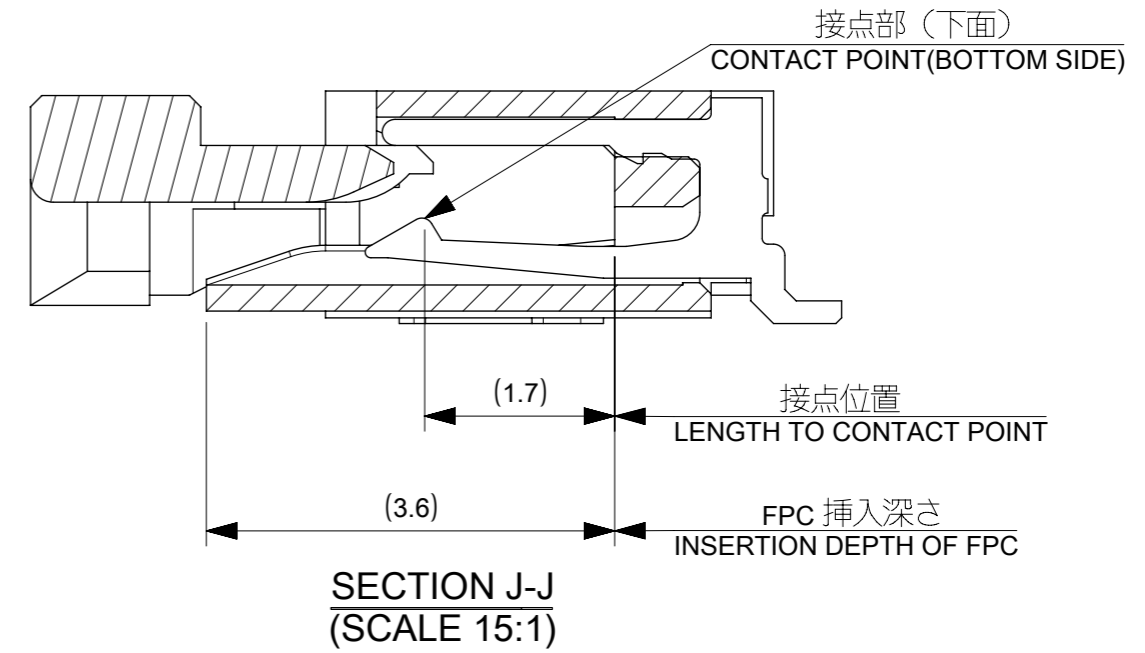
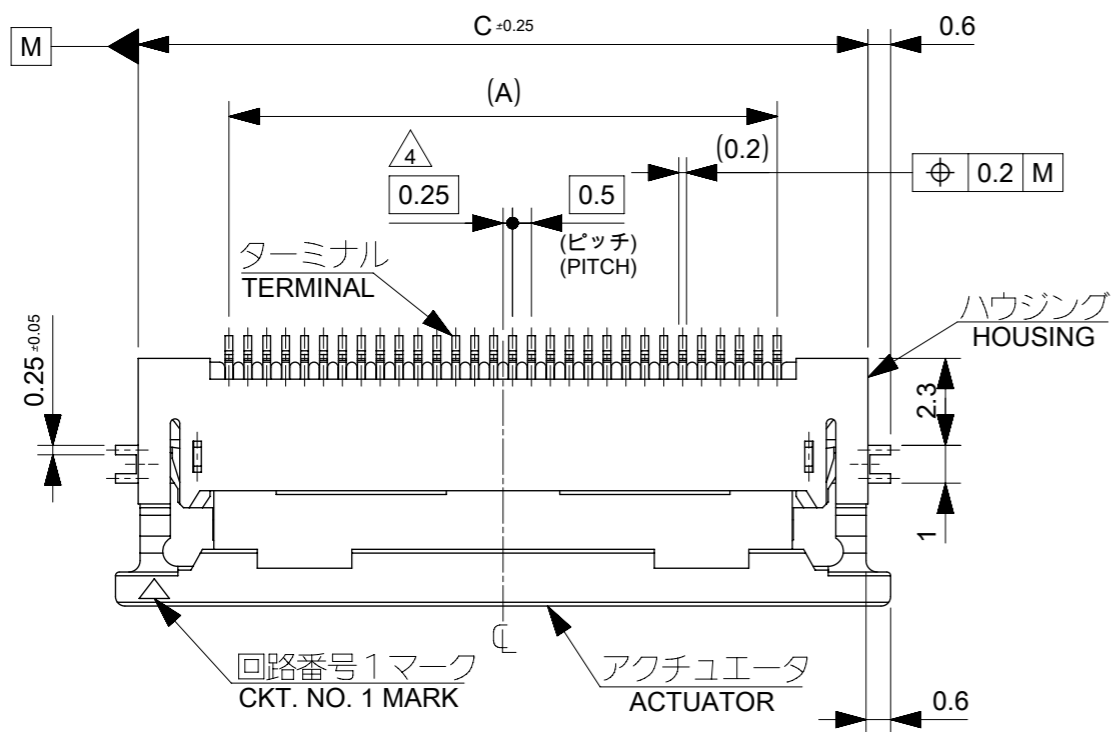

30.5	29.3	25.65	24.5	541325033	50
28.0	26.8	23.15	22.0	541324533	45
27.0	25.8	22.15	21.0	541324333	43
25.5	24.3	20.65	19.5	541324033	40
24.5	23.3	19.65	18.5	541323833	38
23.5	22.3	18.65	17.5	541323633	36
23.0	21.8	18.15	17.0	541323533	35
22.5	21.3	17.65	16.5	541323433	34
22.0	20.8	17.15	16.0	541323333	33
21.5	20.3	16.65	15.5	541323233	32
20.5	19.3	15.65	14.5	541323033	30

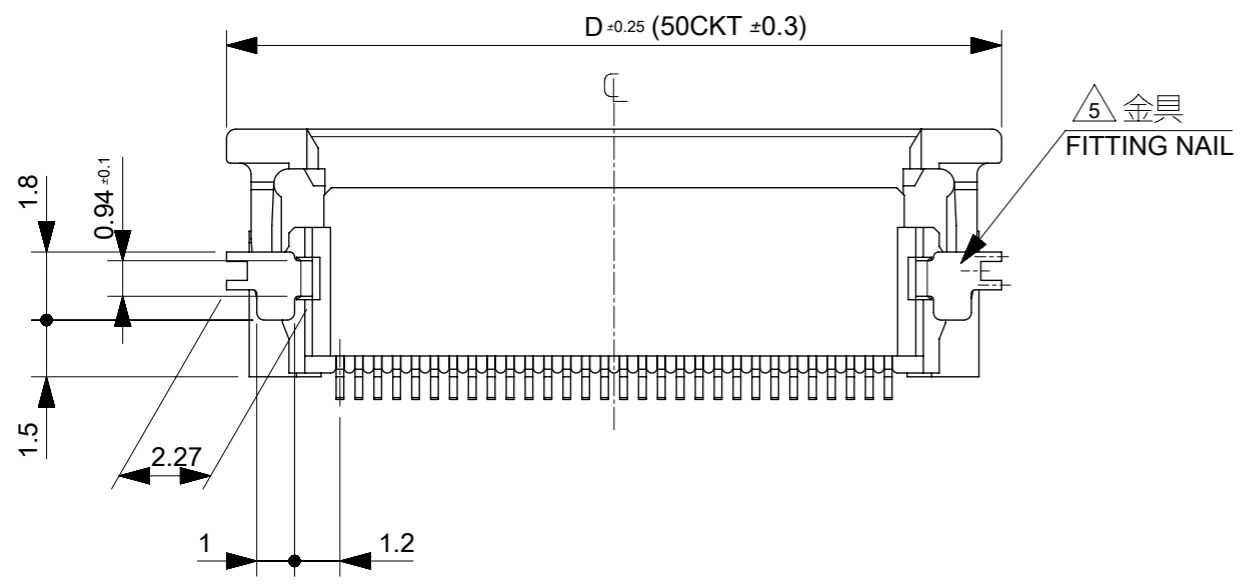

D	C	B	A	EMBOSSED PACKAGE	極数
				オーダー番号 ORDER No.	CKT.

CONNECTOR SERIES NO. : 54132\*\*22

THIS DRAWING CONTAINS INFORMATION THAT IS PROPRIETARY TO MOLEX ELECTRONIC TECHNOLOGIES, LLC AND SHOULD NOT BE USED WITHOUT WRITTEN PERMISSION

2016/02/18	2016/05/23	2016/05/24	GENERAL TOLERANCES (UNLESS SPECIFIED)	DIMENSION UNITS	SCALE	<b>molex</b> <sup>®</sup>			
EC NO: 103444 DRWN: ABABU01 CHK'D: YKOBAYASHI02 APPR: TKUSUHARA01	A	REV	ANGULAR TOL $\pm 3.0^\circ$	MM	5:1				
			4 PLACES $\pm$	DRWN BY	DATE				
			3 PLACES $\pm$	ABABU01	2016/02/18				
			2 PLACES $\pm 0.2$	CHK'D BY	DATE				
			1 PLACE $\pm 0.2$	YKOBAYASHI02	2016/05/23				
			0 PLACES $\pm 0.2$	APPR BY	DATE				
			TKUSUHARA01	2016/05/24		PRODUCT CUSTOMER DRAWING			
			DRAFT WHERE APPLICABLE MUST REMAIN WITHIN DIMENSIONS	DRAWING SIZE	THIRD ANGLE PROJECTION	SERIES	MATERIAL NUMBER	CUSTOMER	
				A3		54132	SEE CHART	GENERAL	
						DOCUMENT NUMBER	DOC TYPE	DOC PART	SHEET NUMBER
						541321000	PSD	000	1 OF 2

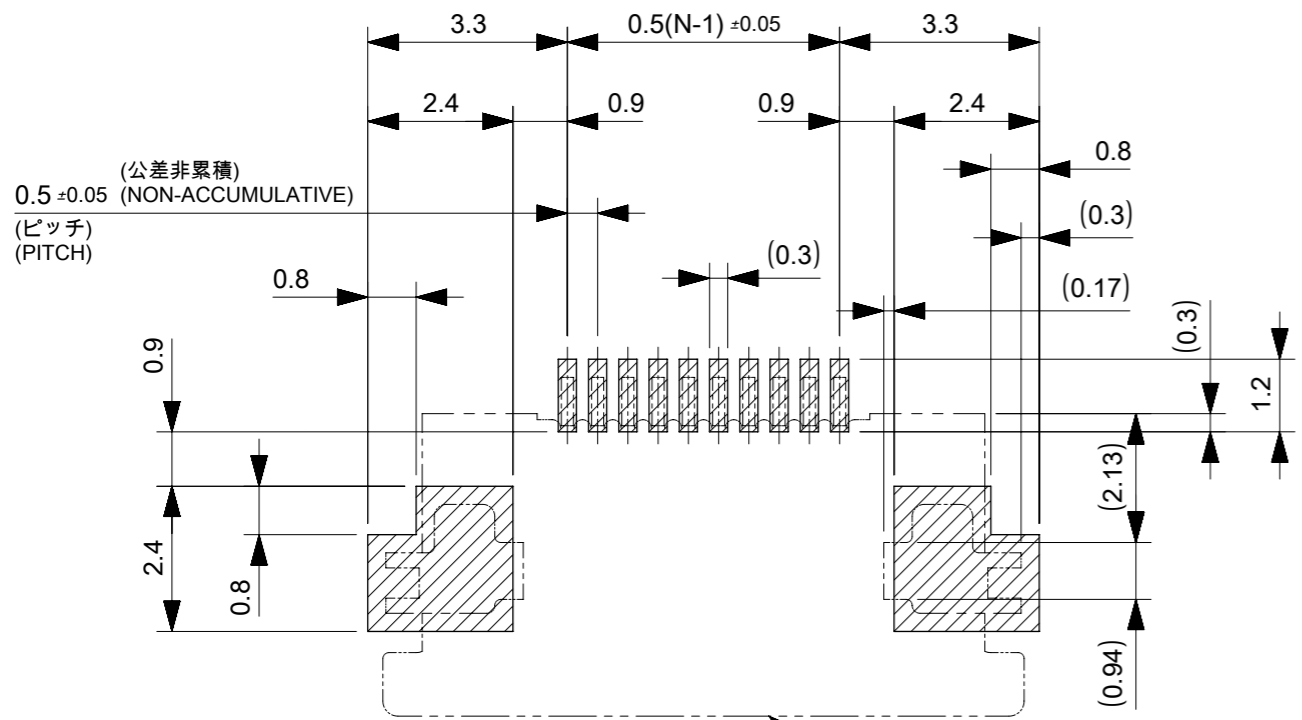

推奨基板レイアウト  
RECOMMENDED PC BOARD PATTERN DIMENSION (REF.)  
(マウント面)  
(MOUNTING SIDE)

マスク厚 : 100μm  
マスク開口率 : 100%  
SCREEN THICKNESS : 100 MICROMETER  
SCREEN OPEN RATIO : 100%

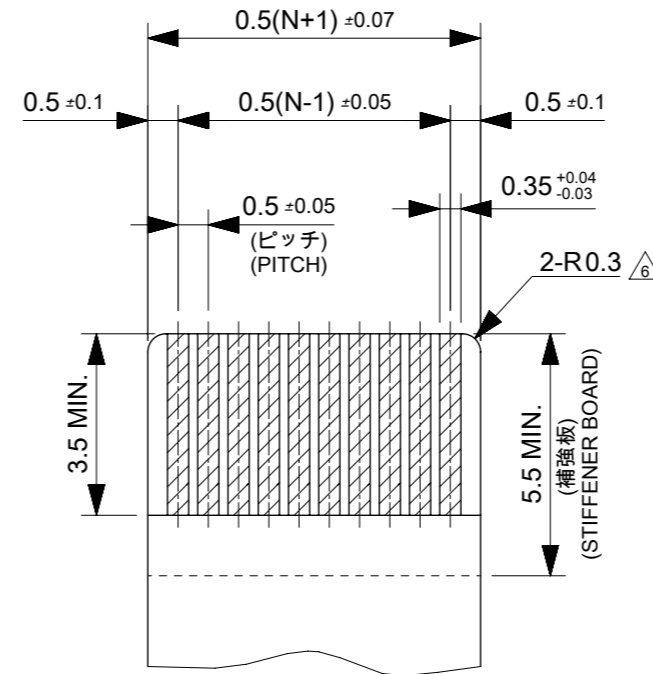

適合 FPC 推奨寸法  
APPLICABLE FPC RECOMMENDED DIMENSION  
(仕上がり厚さ : 0.3±0.03)  
(THICKNESS : 0.3±0.03)

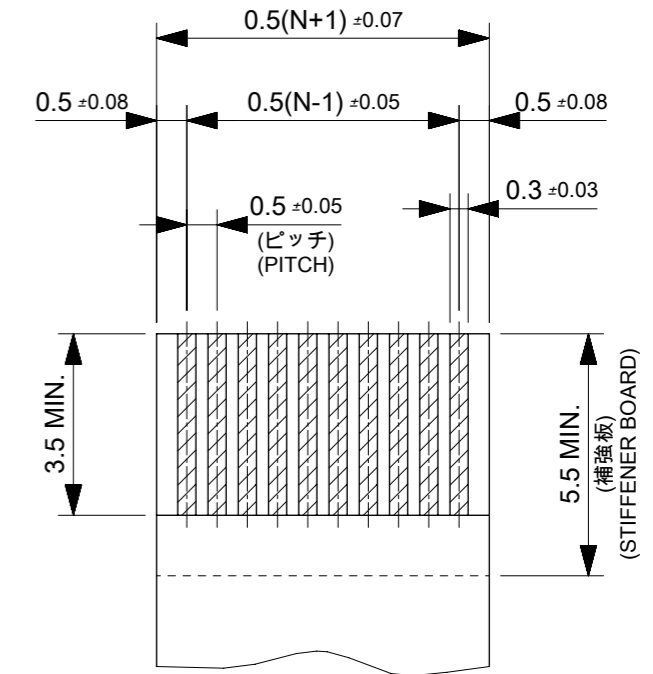

適合 FFC 推奨寸法  
APPLICABLE FFC RECOMMENDED DIMENSION  
(仕上がり厚さ : 0.3±0.03)  
(THICKNESS : 0.3±0.03)

注記 NOTES

- 材質 MATERIAL  
ハウジング : ポリアミド(PA)、ガラス充填、ナチュラル(白)、UL94V-0  
HOUSING : POLYAMIDE, GLASS FILLED, NATURAL, UL94V-0  
アクチュエータ : ポニフェニレンサルファロイド (PPS)、ガラス充填、黒色、UL94V-0  
ACTUATOR : POLYPHENYLENE SULFIDE GLASS FILLED, BLACK, UL94V-0  
ターミナル : リン青銅 (t=0.2)  
TERMINAL : PHOSPHOR BRONZE (t=0.2)  
金具 : リン青銅 (t=0.2)  
NAIL : PHOSPHOR BRONZE (t=0.2)
- めっき仕様 PLATING  
ターミナル TERMINAL  
錫銀ビスマスめっき (1.0μm以上)  
下地 : ニッケルめっき (1.0μm以上)  
TIN SILVER BISMUTH PLATING (1.0 MICROMETER MINIMUM)  
UNDER PLATE : NICKEL PLATING (1.0 MICROMETER MINIMUM)  
金具  
錫めっき (1.0μm以上)  
下地 : ニッケルめっき (1.0μm以上)  
TIN PLATING (1.0 MICROMETER MINIMUM)  
UNDER PLATE : NICKEL PLATING (1.0 MICROMETER MINIMUM)  
3 ソルダータール半田付け面のズレ量、及び金具半田付け面のズレ量は基準面 H に対して上方向0.1MAXIMUM、下方向0.15MAXIMUMとする。

FPC/FFCについて ABOUT FPC/FFC  
打ち抜き方向は導体側から補強板側を推奨します。  
導体部については軟箔銅35μmまたは50μmを推奨します。  
RECOMMENDED PUNCHING DIRECTION:  
FROM CONDUCTOR SIDE TO STIFFENER SIDE  
RECOMMENDED CONDUCTOR SPEC:  
SOFT COPPER FOIL  
RECOMMENDED CONDUCTOR THICKNESS:  
35 MICROMETER OR 50 MICROMETER

FPCについて ABOUT FPC  
補強フィルム材質はポリイミドを推奨します。  
ベースフィルムは25μmを推奨します。  
接着剤は熱硬化接着剤を推奨します。  
尚、接着剤の接点部への付着は導通不良の原因になりますので、染み出しが無い様、お願い致します。  
RECOMMENDED STIFFENER MATERIAL: POLYIMIDE  
RECOMMENDED BASE FILM THICKNESS: 25 MICROMETER  
RECOMMENDED ADHESIVE: THERMOSETTING ADHESIVE

NOTE: PLEASE PUT APPROPRIATE AMOUNT OF ADHESIVE ON ADHEREND BECAUSE THERE IS A POSSIBILITY THAT THE EXTRA ADHESIVE CAUSES THE DEFECT IN ELECTRICAL CONTINUITY.

補強板 : ポリイミド  
REINFORCE BOARD: POLYIMIDE  
熱硬化接着剤  
THERMOSETTING ADHESIVE  
ベ - スフィルム : ポリイミド(25μm)  
BASE FILM: POLYIMIDE(25μm)  
熱硬化接着剤  
THERMOSETTING ADHESIVE  
導体部 : 銅箔 (35μm)  
COPPER FOIL (35μm)  
熱硬化接着剤  
THERMOSETTING ADHESIVE  
カバーレイ : ポリイミド (25μm)  
COVER FILM: POLYIMIDE(25μm)

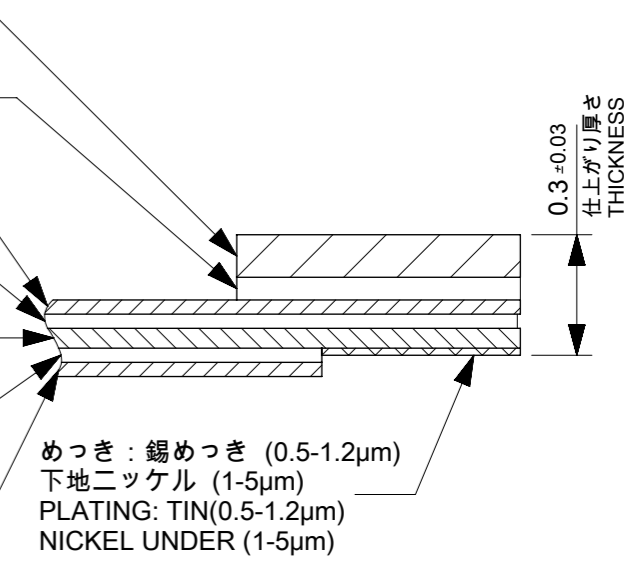

FPC構成推奨仕様  
STRUCTURE OF FPC

- MISALIGNMENT OF SOLDER TAILS AND FITTING NAILS FROM H
- UPPER DIRECTION : 0.1MAXIMUM  
LOWER DIRECTION : 0.15 MAXIMUM.
- 偶数局に適用  
APPLY FOR EVEN CIRCUIT.
  - パターンはくり止め用金具  
FITTING NAIL FOR PREVENTION OF PEELING OF P.C.B. PATTERN.
  - R0.3はFPCの導体にかからないこと  
R0.3 MUST NOT BE OVERLAPED TO PATTERN OF FPC.
  - エンボステープ梱包時は、アクチュエータがロックした状態とする  
IN THE PACKAGE, ACTUATOR SHOULD BE LOCKED.
  - ELV及びRoHS適合品  
ELV AND RoHS COMPLIANT.

THIS DRAWING CONTAINS INFORMATION THAT IS PROPRIETARY TO MOLEX ELECTRONIC TECHNOLOGIES, LLC AND SHOULD NOT BE USED WITHOUT WRITTEN PERMISSION

EC NO: 103444 DRWN: ABABU01 CHK'D: YKOBAYASHI02 APPR: TKUSUHARA01	2016/02/18	2016/05/23	2016/05/24	GENERAL TOLERANCES (UNLESS SPECIFIED)	DIMENSION UNITS	SCALE				
					MM	---				
	4 PLACES ±				ANGULAR TOL ± 3.0 °	DRWN BY		DATE		
	3 PLACES ±					ABABU01		2016/02/18		
2 PLACES ± 0.2				CHK'D BY	DATE	0.5MM FPC CONN ZIF R/A HOUSING ASSY (LOWER CONTACT)				
1 PLACE ± 0.2				YKOBAYASHI02	2016/05/23	PRODUCT CUSTOMER DRAWING				
0 PLACES ± 0.2				APPR BY	DATE	SERIES MATERIAL NUMBER CUSTOMER				
DRAFT WHERE APPLICABLE MUST REMAIN WITHIN DIMENSIONS				TKUSUHARA01	2016/05/24	54132	GENERAL			
DRAWING SIZE		THIRD ANGLE PROJECTION		DOCUMENT NUMBER				DOC TYPE	DOC PART	SHEET NUMBER
A3				541321000		PSD	000	2 OF 2		