

FACE VIEW - MALE INSERT

SCALE 1.5 : 1

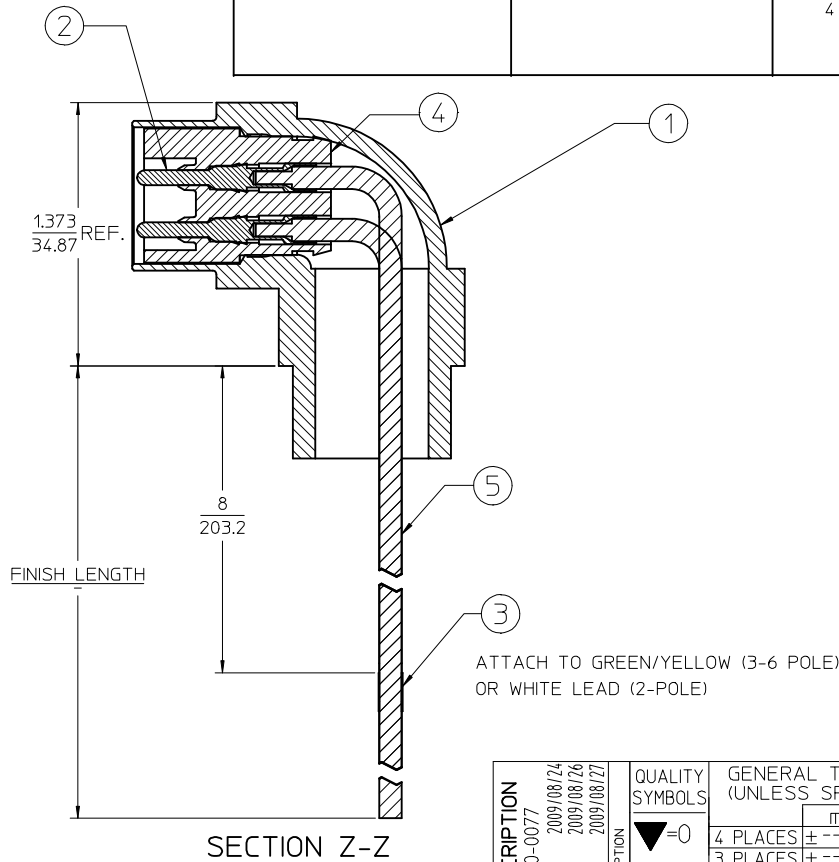
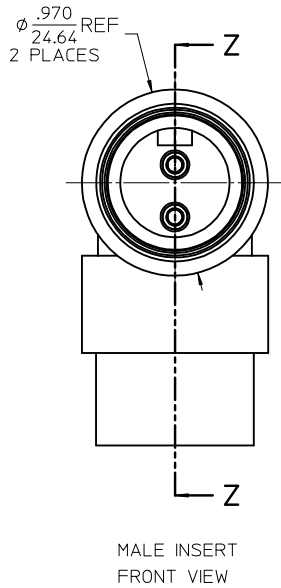
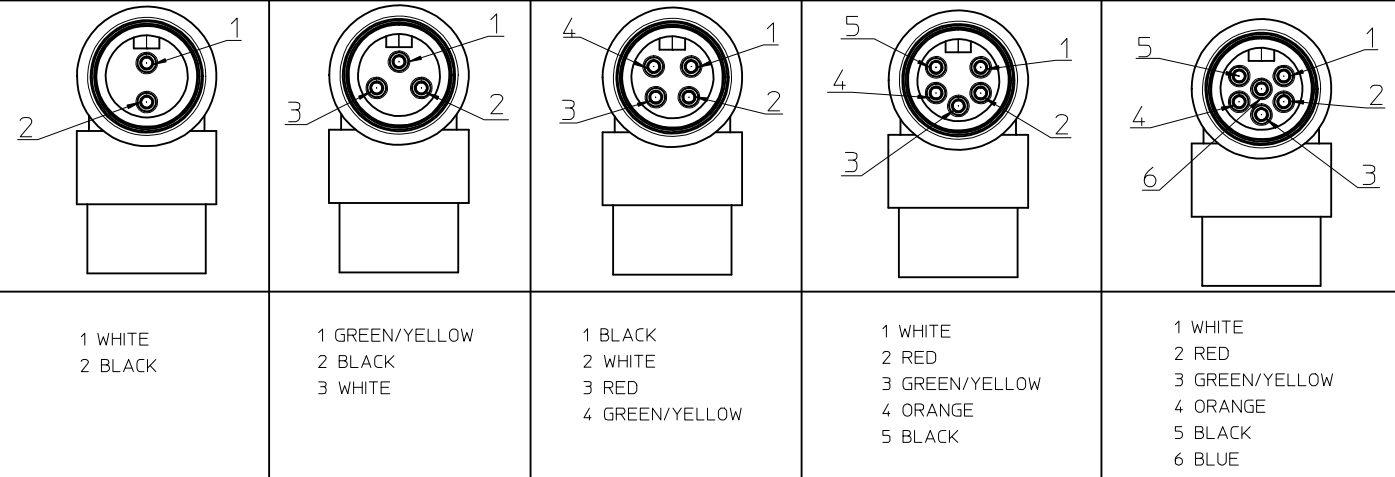

FINAL ASSEMBLY
1300130090

ENTER DESCRIPTION EC NO: MNA2010-0077 DRW: NKUMAR01 2009/08/24 CHKD: 2009/08/26 APPR: JFMURPHY 2009/08/27	QUALITY SYMBOLS ▽=0 ▽=0	GENERAL TOLERANCES (UNLESS SPECIFIED)		DIMENSION STYLE IN/MM	SCALE 2:1	DESIGN UNITS INCH	THIRD ANGLE PROJECTION	
		4 PLACES ± --- ± --- 3 PLACES ± --- ± --- 2 PLACES ± --- ± --- 1 PLACE ± --- ± ---	mm INCH	DRAWN BY NKUMAR01 DATE 24/08/09	CHECKED BY BWOODMAN DATE 24/08/09	TITLE MC 2P MR 12IN. 90D 16/1 PVC		
		ANGULAR ±1/2°		APPROVED BY JFMURPHY DATE 2009/08/26	MOLEX INCORPORATED			
		DRAFT WHERE APPLICABLE MUST REMAIN WITHIN DIMENSIONS		MATERIAL NO. SEE SHEET 2 SIZE C	DOCUMENT NO. SD-130013-090	SHEET NO. 1 OF 2		

MALE 90° RECEPTACLE ASSEMBLY

Sl. No.	DESCRIPTION	MATERIAL	FINISH	QUANTITY				
				2 POLE	3 POLE	4 POLE	5 POLE	6 POLE
1	MC RIGHT ANGEL SHELL 90DEG	ZINC DIECAST	BLACK E-COAT	1	1	1	1	1
2	PIN CONTACT 16AWG	COPPER ALLOY	GOLD PLATED	2	3	4	5	6
3	LABEL	PLASTIC FILM	BLACK/YELLOW	1	1	1	1	1
4	2P MALE INSERT PVC A SIZE	PVC	YELLOW	1				
	3P MALE INSERT PVC A SIZE	PVC	YELLOW		1			
	4P MALE INSERT PVC A SIZE	PVC	YELLOW			1		
	5P MALE INSERT PVC A SIZE	PVC	YELLOW				1	
	6P MALE INSERT PVC A SIZE	PVC	YELLOW					1
5	#16-1 WHT PVC WIRE UL1015	PVC JACKET	WHITE	1	1	1	1	1
	#16-1 RED PVC WIRE UL1015	PVC JACKET	RED			1	1	1
	#16-1 ORN PVC WIRE UL1015	PVC JACKET	ORANGE				1	1
	#16-1 GRN/YEL PVC WIRE UL1015	PVC JACKET	GREEN/YELLOW		1	1	1	1
	#16-1 BLU PVC WIRE UL1015	PVC JACKET	BLUE					1
	#16-1 BLK PVC WIRE UL1015	PVC JACKET	BLACK	1	1	1	1	1

PART NUMBER	DESCRIPTION	FINISHED LENGTH
1300130090	1R2007A20A120	12.0" +.75" -0 [0.3M +19.1MM -0]
1300130247	1R3007A20A120	12.0" +.75" -0 [0.3M +19.1MM -0]
1300130386	1R4007A20A120	12.0" +.75" -0 [0.3M +19.1MM -0]
1300130534	1R5007A20A120	12.0" +.75" -0 [0.3M +19.1MM -0]
1300130612	1R6007A20A120	12.0" +.75" -0 [0.3M +19.1MM -0]

POLE COUNT	MAX. VOLTAGE RATING	MAX. CURRENT RATING
2 POLE	600 VOLTS	13 AMPS
3 POLE	600 VOLTS	13 AMPS
4 POLE	600 VOLTS	10 AMPS
5 POLE	600 VOLTS	8 AMPS
6 POLE	600 VOLTS	8 AMPS

ENTER DESCRIPTION EC NO: MNA2010-0077 DRWN: NKUMAR01 2009/08/24 CHKD: 2009/08/26 APPR: JF MURPHY 2009/08/27	QUALITY SYMBOLS 	GENERAL TOLERANCES (UNLESS SPECIFIED)		DIMENSION STYLE IN/MM		SCALE 2:1	DESIGN UNITS INCH	THIRD ANGLE PROJECTION
		4 PLACES ± --- ± --- 3 PLACES ± --- ± --- 2 PLACES ± --- ± --- 1 PLACE ± --- ± ---	mm INCH ± --- ± --- ± --- ± --- ± --- ± ---	DRAWN BY NKUMAR01	DATE 24/08/09	TITLE MC 2P MR 12IN. 90D 16/1 PVC		
		ANGULAR ±1/2°		CHECKED BY BWOODMAN	DATE 24/08/09	MOLEX INCORPORATED		
		DRAFT WHERE APPLICABLE MUST REMAIN WITHIN DIMENSIONS		APPROVED BY JFMURPHY	DATE 2009/08/26	MATERIAL NO. 9999999999	DOCUMENT NO. SD-130013-090	
A	REV	SHEET NO. 2 OF 2		THIS DRAWING CONTAINS INFORMATION THAT IS PROPRIETARY TO MOLEX INCORPORATED AND SHOULD NOT BE USED WITHOUT WRITTEN PERMISSION				