

PARTIAL1
Scale 2:1

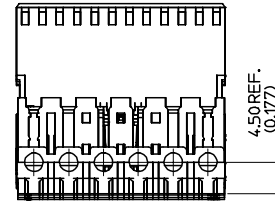

- NOTES:
1. MATERIALS
HOUSING: UNFILLED NYLON 6/6, RATED UL 94V-2
FOR COLOURS, SEE CHARTS ON SHEETS 2-6.
TERMINALS: PHOSPHOR BRONZE, 0.40/(0.016) THICK REF.
PLATING: 5um/(200uin) MIN PURE Sn
 2. PRODUCT CONFORMS TO SPECIFICATION PS-99020-0037
 3. ACCEPTS CABLE, PER ES-99036-0008 OR ES-99036-0009
AS PER THE APPLICATION SPECIFICATION AS-99033-0004
 4. SEE SUBSEQUENT SHEETS FOR PART NUMBERS SHOWING
THE VARIOUS CODING, KEYING AND LATCHING OPTIONS

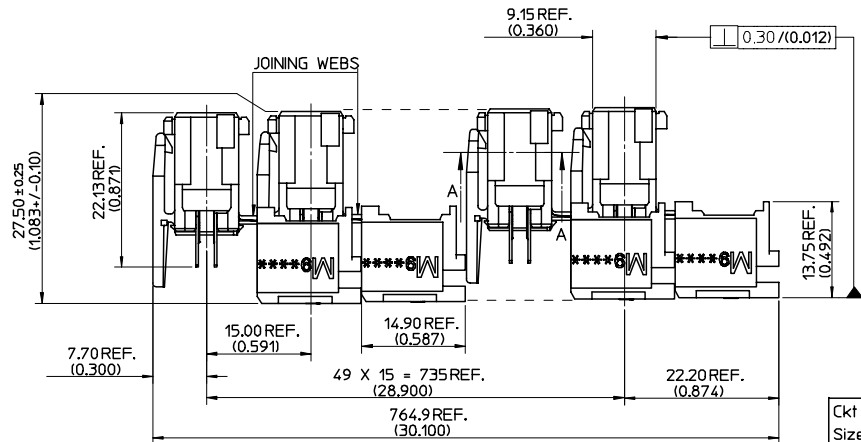
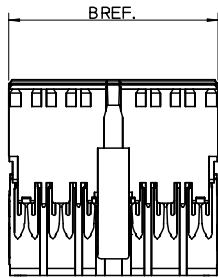
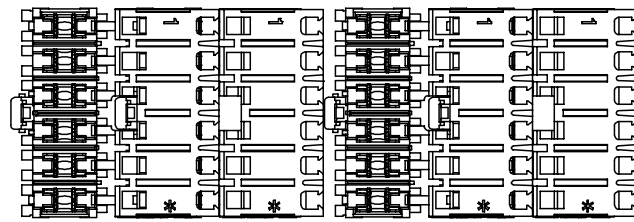

Ckt Size	A	B
2	5.00/(0.197)	9.90/(0.400)
3	10.00/(0.394)	14.90/(0.587)
4	15.00/(0.591)	19.90/(0.783)
5	20.00/(0.787)	24.90/(0.980)
6	25.00/(0.984)	29.90/(1.177)
7	30.00/(1.181)	34.90/(1.374)
8	35.00/(1.378)	39.90/(1.571)
9	40.00/(1.575)	44.90/(1.768)
10	45.00/(1.772)	49.90/(1.965)
11	50.00/(1.969)	54.90/(2.161)
12	55.00/(2.165)	59.90/(2.358)

CKT	NO. OF CONNECTORS PER TRAY, 99025-0021	NO. OF CONNECTORS PER BOX
2	1200	3600
3	750	2250
4	600	1800
5	450	1350
6	300	900
7	300	900
8	300	900
9	150	450
10	150	450
11	150	450
12	150	450

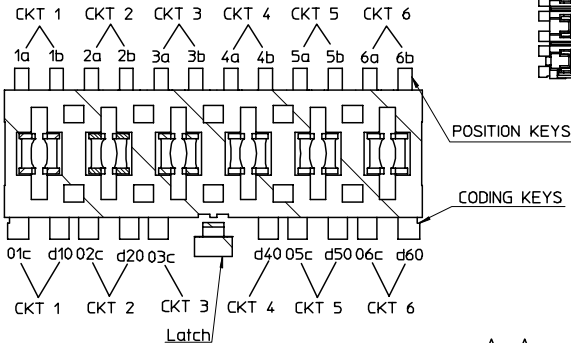

A-A
Scale 4:1

UPDATED TO ANNON ELC NO. E2007-0946 DRAWN: BRUTILE 2007/11/07 CHKD: 2007/11/21 APPR: BMAGUIRE 2007/11/21 REV: AB	QUALITY SYMBOLS ▽=0 ▽=0	GENERAL TOLERANCES (UNLESS SPECIFIED) 4 PLACES ± --- ± --- 3 PLACES ± 0.025 ± --- 2 PLACES ± 0.05 ± --- 1 PLACE ± 0.1 ± --- ANGULAR ± 1/2°	DIMENSION STYLE MM ONLY	SCALE 2:1	DESIGN UNITS METRIC	THIRD ANGLE PROJECTION
	DRAWN BY PC DATE 94/02/14	CHECKED BY BMAGUIRE DATE 94/02/14	APPROVED BY MWILHITE DATE 94/02/14	MATERIAL NO. DOCUMENT NO.	TITLE 5MM APPLI-MATE 6A/10A F-INDIRECT CONN ASSY	MOLEX INCORPORATED

DRAFT WHERE APPLICABLE MUST REMAIN WITHIN DIMENSIONS

SEE CHARTS

THIS DRAWING CONTAINS INFORMATION THAT IS PROPRIETARY TO MOLEX INCORPORATED AND SHOULD NOT BE USED WITHOUT WRITTEN PERMISSION

MOLEX PART NO	CIRCUIT SIZE	COLOUR	POSITION KEYS	CODING KEYS	LATCH POSITION	CONFIGURATION	REF
90833-0001 90833-0002	2	NATURAL BLUE	ALL	ALL	1/2		K00
90833-0003 90833-0051	2	NATURAL YELLOW	1b 2a	ALL	1/2		K01
90833-0004 90833-0050 90833-0026	2	NATURAL YELLOW GREEN	1a 2b	01c	1/2		K02
90833-0005 90833-0018 90833-0053	2	BLUE NATURAL YELLOW	2a 2a	ALL	1/2		K03
90833-0006 90833-0019 90833-0025	2	GREY NATURAL GREEN	1a 2b	d20	1/2		K05
90833-0007 90833-0008	2	NATURAL YELLOW	1b 2b	01c	1/2		K09
90833-0009 90833-0010	2	NATURAL YELLOW	1a 2a	01c	1/2		K10
90833-0054	2	NATURAL	2b	ALL	1/2		K15
90833-0058	2	NATURAL	1a 1b	ALL	1/2		K47
90833-0060	2	BLUE	1a 2b	ALL	1/2		K48
90833-0027 90833-0062	2 2	YELLOW NATURAL	2b	NONE	1/2		K11
90833-0066	2	NATURAL	1a 1b	01c	1/2		K04
90833-0028	2	NATURAL	2a	d20	1/2		K37
90833-0070	2	NATURAL	1a, 1b	d20	1/2		K13
90833-0071	2	NATURAL	2a, 2b	01c	1/2		K32

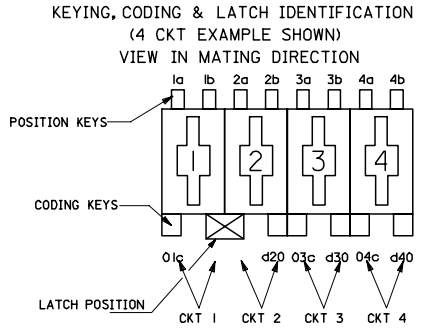

MOLEX PART NO	CIRCUIT SIZE	COLOUR	POSITION KEYS	CODING KEYS	LATCH POSITION	CONFIGURATION	REF
90833-0011 90833-0057 90833-0061	2 2 2	BLUE NATURAL YELLOW	1a	ALL	1/2		K12
90833-0012 90833-0052	2	NATURAL YELLOW	1b 2a	01c	1/2		K14
90833-0013 90833-0014 90833-0048	2	NATURAL YELLOW GREEN	ALL	01c	1/2		K33
90833-0015 90833-0059 90833-0074	2	GREY WHITE NATURAL	ALL	d20	1/2		K34
90833-0016 90833-0069	2 2	GREY NATURAL	1b 2b	d20	1/2		K35
90833-0017 90833-0072	2	GREY NATURAL	2a, 2b	d20	1/2		K39
90833-0020	2	NATURAL	1a 1b	01c	1/2		K04
90833-0021 90833-0063	2 2	NATURAL BLUE	1b 1b	ALL	1/2 1/2		K16
90833-0022	2	NATURAL	1a 2b	NONE	1/2		K06
90833-0032	2	NATURAL	2b	d20	1/2		K38
90833-0047	2	NATURAL	1a 2a	ALL	1/2		K44
90833-0056	2	NATURAL	1b 2a 2b	d20	1/2		K07
90833-0064 90833-0073	2	WHITE NATURAL	1b, 2a	d20	1/2		K46

UPDATED TO ANNON EIC NO: E2007-0946 DRAWN: BRUTTLE 2007/11/07 CHKD: 2007/11/21 APPR: BMAGUIRE 2007/11/21 REV DESCRIPTION	QUALITY SYMBOLS ▽=0 ▽=0	GENERAL TOLERANCES (UNLESS SPECIFIED) <table border="1"> <tr> <th></th> <th>mm</th> <th>INCH</th> </tr> <tr> <td>4 PLACES</td> <td>± .025</td> <td>± .001</td> </tr> <tr> <td>3 PLACES</td> <td>± 0.025</td> <td>± .001</td> </tr> <tr> <td>2 PLACES</td> <td>± 0.05</td> <td>± .002</td> </tr> <tr> <td>1 PLACE</td> <td>± 0.1</td> <td>± .004</td> </tr> </table>		mm	INCH	4 PLACES	± .025	± .001	3 PLACES	± 0.025	± .001	2 PLACES	± 0.05	± .002	1 PLACE	± 0.1	± .004	DIMENSION STYLE MM ONLY	SCALE 1:1	DESIGN UNITS METRIC	THIRD ANGLE PROJECTION
		mm	INCH																		
	4 PLACES	± .025	± .001																		
	3 PLACES	± 0.025	± .001																		
2 PLACES	± 0.05	± .002																			
1 PLACE	± 0.1	± .004																			
DRAWN BY PC	DATE 94/02/14	CHECKED BY BMAGUIRE	DATE 94/02/14	TITLE 5MM APPLI-MATE 6A/10A F-INDIRECT CONN ASSY																	
APPROVED BY MWILHITE	DATE 94/02/14	MATERIAL NO.			DOCUMENT NO.																
DRAFT WHERE APPLICABLE MUST REMAIN WITHIN DIMENSIONS	SEE CHARTS	MOLEX INCORPORATED			SD-90833-001	SHEET NO. 2 OF 6															

	13	12	11	10	9	8	7	6	5	4	3	2	1
	MOLEX PART NO	CIRCUIT SIZE	COLOUR	POSITION KEYS	CODING KEYS	LATCH POSITION	CONFIGURATION	REF					
J	90833-0500	3	NATURAL	ALL	ALL	1/2		K00					
	90833-0501	3	NATURAL	ALL	ALL	2/3		K90					
I	90833-0502	3	NATURAL	1b	01c d20	1/2		K01					
	90833-0503	3	YELLOW	ALL	d20	1/2		K40					
	90833-0504	3	GREY	ALL	d10	2/3		K41					
	90833-0505	3	GREY	1a 2a	d10	2/3		K42					
H	90833-0532	3	BLACK	1a 3a	d20	1/2		K43					
	90833-0506	3	YELLOW	1a 3a	d20	1/2		K43					
	90833-0507	3	YELLOW	2a	d10 d30	2/3		K44					
G	90833-0508	3	NATURAL	1a	03c	1/2		K04					
	90833-0509	3	GREY	1a 1b	d10	2/3		K52					
	90833-0510	3	YELLOW	1a 1b	d20	1/2		K53					
F	90833-0511	3	NATURAL	1a 1b	d30	1/2		K05					
	90833-0524	3	NATURAL	1b 2a 2b	d30	1/2		K33					
	90833-0526	3	NATURAL	ALL	d10 d30	2/3		K38					
E	90833-0528	3	NATURAL	1a 3a	01c	1/2		K07					
	90833-0529	3	NATURAL	1b 3a	01c	1/2		K03					
	90833-0533	3	GREY	1b 3a	01c	1/2		K03					
	90833-0530	3	NATURAL	2a	02c d30	2/3		K57					
D	90833-0531	3	NATURAL	2b	d20	1/2		K08					
	90833-0513	3	NATURAL	1b	d20 03c	1/2		K09					
	90833-0535	3	NATURAL	1a 2a	d30	2/3							
C	90833-0536	3	NATURAL	2a	d10 d30	2/3		K44					
	90833-0537	3	BLUE	1a	03c	1/2		K**					
B	90833-0534	3	NATURAL	1a 1b 2a 3a	01c 02c d30	2/3		K12					
	90833-0540	3	NATURAL	3b	01c d30	1/2		K37					
	90833-0541	3	NATURAL	2b 3b	d10 02c	2/3		K02					
	90833-0542	3	NATURAL	1a 3a	01c	1/2		K-					
A	90833-0543	3	NATURAL	1a 3a	03c	1/2		K98					

	MOLEX PART NO	CIRCUIT SIZE	COLOUR	POSITION KEYS	CODING KEYS	LATCH POSITION	CONFIGURATION	REF					
	90833-1251	4	NATURAL	ALL	ALL	1/2 3/4		K00					
	90833-1252	4	BLUE	ALL	ALL	1/2 3/4		K00					
	90833-1253	4	YELLOW	ALL	ALL	1/2 3/4		K00					
	90833-1254	4	NATURAL	1b	03c d40	1/2 3/4		K01					
	90833-1255	4	YELLOW	3a	d20 03c	1/2 3/4		K33					
	90833-1256	4	BLUE	ALL	01c	1/2 3/4		K34					
	90833-1257	4	NATURAL	ALL	d20 03c	1/2 3/4		K35					
	90833-1258	4	BLUE	ALL	d40	1/2 3/4		K36					
	90833-1259	4	NATURAL	1b	d20 03c	1/2 3/4		K38					
	90833-1260	4	BLUE	1b 2a	d40	1/2 3/4		K39					
	90833-1261	4	BLUE	1b 3b	d40	1/2 3/4		K49					
	90833-1262	4	BLUE	1b 3b	01c	1/2 3/4		K54					
	90833-1264	4	NATURAL	1a 4b	d40	1/2 3/4		K03					
	90833-1271	4	ORANGE	1a 3a	d40	1/2 3/4		K06					
	90833-1272	4	GREY	1b	03c d40	1/2 3/4		K01					
	90833-1273	4	NATURAL	1a 3a 3b	01c d20 d40	1/2 3/4		K32					
	90833-1277	4	YELLOW	1a 2b 4b	d40	1/2 3/4		K62					
	90833-1267	4	NATURAL	1b 2a 3a 4b	01c d40	1/2 3/4		K37					
	90833-1279	4	NATURAL	1a 4b	01c	1/2 3/4		K02					
	90833-1282	4	NATURAL	1a 2a 4a	01c 03c d40	1/2 3/4		K43					
	90833-1276	4	NATURAL	3b	d30	2/3		K04					
	90833-1283	4	NATURAL	1a 1b 3a 3b	01c 03c	1/2 3/4		K93					
	90833-1284	4	NATURAL	1a 3a	01c d40	1/2 3/4		K87					

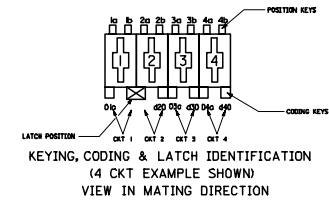

UPDATED TO ANNON
ECN NO: E2007-0946
DRAWN: BRUTILE
CHKD: CHIKO
APPR: BMAGUIRE
REV: AB

2007/11/07
2007/11/24
2007/11/24

DESCRIPTION

QUALITY SYMBOLS
▽=0
▽=0

DRAFT WHERE APPLICABLE
MUST REMAIN
WITHIN DIMENSIONS

GENERAL TOLERANCES
(UNLESS SPECIFIED)

	mm	INCH
4 PLACES	± .005	± .0004
3 PLACES	± 0.025	± .0010
2 PLACES	± 0.05	± .0020
1 PLACE	± 0.1	± .0040
ANGULAR ±1/2°		

DIMENSION STYLE
MM ONLY

SCALE
1:1

DESIGN UNITS
METRIC

THIRD ANGLE
PROJECTION

DRAWN BY: PC
DATE: 94/02/14

CHECKED BY: BMAGUIRE
DATE: 94/02/14

APPROVED BY: MWILHITE
DATE: 94/02/14

MATERIAL NO. DOCUMENT NO. SD-90833-001

MOLEX INCORPORATED

THIS DRAWING CONTAINS INFORMATION THAT IS PROPRIETARY TO MOLEX
INCORPORATED AND SHOULD NOT BE USED WITHOUT WRITTEN PERMISSION

SHEET NO.
3 OF 6

MOLEX PART NO	CIRCUIT SIZE	COLOUR	POSITION KEYS	CODING KEYS	LATCH POSITION	CONFIRGURATION	REF.
90833-2001	5	NATURAL	1a 3a	01c d30	1/2 4/5		K30
90833-2002	5	NATURAL	1a 5b	01c d20 03c d50	1/2 3/4		K31
90833-2006	5	NATURAL	2a	01c d50	2/3 4/5		K43
90833-2007	5	NATURAL	ALL	01c d50	2/3 4/5		K42
90833-2008	5	NATURAL	ALL	ALL	2/3 4/5		K92
90833-2010	5	NATURAL	ALL	ALL	1/2 3/4		K00
90833-2011	5	NATURAL	ALL	ALL	1/2 4/5		K90
90833-2012	5	NATURAL	2a 4b	01c d20 d40	1/2 3/4		K44
90833-2019	5	NATURAL	1a 3a	01c d30 d50	1/2 4/5		K49
90833-2023	5	BLUE	NONE	d20 d40	1/2 3/4		K75
90833-2025	5	NATURAL	NONE	01c d40	1/2 3/4		K**
90833-2026	5	GREEN	2b	d20 d50	1/2 3/4		K**
90833-2027	5	NATURAL	1a 5b	01c d20 03c d50	1/2 3/4		K31
90833-2028	5	NATURAL	1a 4a	d30	1/2 4/5		K04
90833-2029	5	NATURAL	1a 3a	01c d50	1/2		K**

MOLEX PART NO	CIRCUIT SIZE	COLOUR	POSITION KEYS	CODING KEYS	LATCH POSITION	CONFIRGURATION	REF.
90833-2024	5	NATURAL	2a	01C, d50	2/3, 4/5		K43

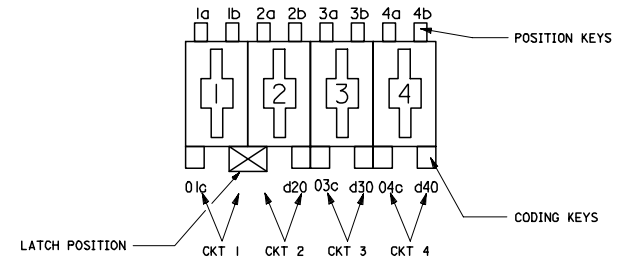

KEYING, CODING & LATCH IDENTIFICATION
(4 CKT EXAMPLE SHOWN)
VIEW IN MATING DIRECTION

UPDATED TO ANNON
ECN NO: E2007-0946
DRAWN: BR01/TLE 2007/11/07
CHKD: 2007/11/21
APPR: BMAGUIRE 2007/11/21
REV AB

QUALITY SYMBOLS ▽=0 ▽=0	GENERAL TOLERANCES (UNLESS SPECIFIED)		DIMENSION STYLE MM ONLY		SCALE 1:1	DESIGN UNITS METRIC	THIRD ANGLE PROJECTION
	4 PLACES ± ---	± ---	mm	INCH	DRAWN BY PC	DATE 94/02/14	TITLE 5MM APPLI-MATE 6A/10A F-INDIRECT CONN ASSY
3 PLACES ± 0.025	± ---	± 0.025	± ---	± ---	CHECKED BY BMAGUIRE	DATE 94/02/14	
2 PLACES ± 0.05	± ---	± 0.05	± ---	± ---	APPROVED BY MWILHITE	DATE 94/02/14	
1 PLACE ± 0.1	± ---	± 0.1	± ---	± ---	MATERIAL NO.	DOCUMENT NO.	
ANGULAR ±1/2°		DRAFT WHERE APPLICABLE MUST REMAIN WITHIN DIMENSIONS		SEE CHARTS		MOLEX INCORPORATED	
						SD-90833-001	
						SHEET NO. 4 OF 6	

MOLEX PART NO	CIRCUIT SIZE	COLOUR	POSITION KEYS	CODING KEYS	LATCH POSITION	CONFIGURATION	REF.
90833-2750	6	NATURAL	ALL	ALL	2/3 4/5		K90
90833-2751	6	GREY	ALL	02c d50	2/3 4/5		k38
90833-2752	6	GREY	1b	02c d50	2/3 4/5		k40
90833-2765	6	NATURAL	1b	03c d60	1/2 5/6		k91
90833-2764	6	NATURAL	ALL	ALL	1/2 5/6		k53
90833-2773	6	NATURAL	5b	01c d40	1/2 5/6		k61
90833-2776	6	NATURAL	1b 6a	d30	1/2 5/6		
90833-2777	6	NATURAL	2b 6b	d40	1/2 5/6		k04
90833-2778	6	BLUE	1b	d10 d50	2/3 4/5		k88
90833-2779	6	NATURAL	5b	02C, 06C	3/4		k**
90833-2780	6	NATURAL	1b 2a	d20 03c d60	1/2 4/5		k**
90833-2781	6	NATURAL	NDNE	d20, d60	1/2, 5/6		k108

MOLEX PART NO	CIRCUIT SIZE	COLOUR	POSITION KEYS	CODING KEYS	LATCH POSITION	CONFIGURATION	REF.
90833-3500	7	YELLOW	2b	d20 d60	1/2 5/6		K32
90833-3501	7	YELLOW	ALL	d20 d60	1/2 5/6		K33
90833-3502	7	YELLOW	ALL	d20 07c	1/2 5/6		K36
90833-3503	7	YELLOW	2b	d20 07c	1/2 5/6		K37
90833-3521	7	NATURAL	2b	d20 07c	1/2 5/6		
90833-3513	7	NATURAL	ALL	ALL	1/2 5/6		K00
90833-3514	7	NATURAL	NONE	d20	1/2 5/6		K44
90833-3518	7	NATURAL	ALL	ALL	2/3 6/7		K90
90833-3520	7	NATURAL	ALL	02c d50	2/3 6/7		K49
90833-3522	7	NATURAL	NONE	d20 03c 07c	5/6		K**
90833-3523	7	NATURAL	1a 6b	03c 07c	4/5		K**
90833-3524	7	NATURAL	1a 1b 2a 3a 4a 5b 6a 6b 7a	d20 07c	1/2 5/6		K**
90833-3521	7	NATURAL	2b	d20 07c	1/2 5/6		K37

MOLEX PART NO	CIRCUIT SIZE	COLOUR	POSITION KEYS	CODING KEYS	LATCH POSITION	CONFIGURATION	REF.
90833-4250	8	NATURAL	ALL	ALL	3/4 5/6		K00
90833-4251	8	NATURAL	1b 3a 3b 5a 5b 7a 8a	01c d20 03c 05c 07c	3/4 5/6		K36
90833-4256	8	NATURAL	ALL	ALL	1/2 7/8		K90
90833-4255	8	NATURAL	ALL	03c d60	1/2 7/8		K39
90833-4261	8	BLUE	ALL	03c d60	1/2 7/8		
90833-4254	8	NATURAL	2b 8a	03c d60	1/2 7/8		
90833-4264	8	NATURAL	8b	02c d30 07c	2/3 7/8		

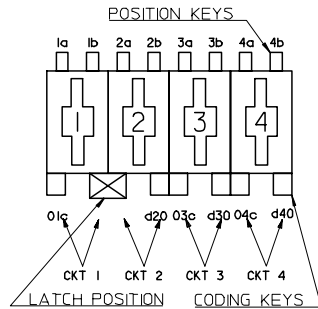

KEYING, CODING & LATCH IDENTIFICATION
(4CKT EXAMPLE SHOWN)
VIEW IN MATING DIRECTION

UPDATED TO ANNON EEC NO: E2007-0946 DRAWN: BRITTON CHKD: CHIKO APPR: BMAGUIRE 2007/11/07 2007/11/21 2007/11/21	QUALITY SYMBOLS 	GENERAL TOLERANCES (UNLESS SPECIFIED) <table border="1"> <tr> <th></th> <th>mm</th> <th>INCH</th> </tr> <tr> <td>4 PLACES</td> <td>± .---</td> <td>± .---</td> </tr> <tr> <td>3 PLACES</td> <td>± 0.025</td> <td>± .---</td> </tr> <tr> <td>2 PLACES</td> <td>± 0.05</td> <td>± .---</td> </tr> <tr> <td>1 PLACE</td> <td>± 0.1</td> <td>± .---</td> </tr> </table>		mm	INCH	4 PLACES	± .---	± .---	3 PLACES	± 0.025	± .---	2 PLACES	± 0.05	± .---	1 PLACE	± 0.1	± .---	DIMENSION STYLE MM ONLY DRAWN BY: PC DATE: 94/02/14 CHECKED BY: BMAGUIRE DATE: 94/02/14 APPROVED BY: MWILHITE DATE: 94/02/14	SCALE: 1:1 DESIGN UNITS: METRIC THIRD ANGLE PROJECTION
		mm	INCH																
4 PLACES	± .---	± .---																	
3 PLACES	± 0.025	± .---																	
2 PLACES	± 0.05	± .---																	
1 PLACE	± 0.1	± .---																	
DRAFT WHERE APPLICABLE MUST REMAIN WITHIN DIMENSIONS	SEE CHARTS THIS DRAWING CONTAINS INFORMATION THAT IS PROPRIETARY TO MOLEX INCORPORATED AND SHOULD NOT BE USED WITHOUT WRITTEN PERMISSION	MOLEX INCORPORATED MATERIAL NO. SD-90833-001 DOCUMENT NO.	SHEET NO. 5 OF 6																

MOLEX PART NO	CIRCUIT SIZE	COLOUR	POSITION KEYS	CODING KEYS	LATCH POSITION	CONFIGURATION	REF
90833-5000	9	NATURAL	ALL	ALL	3/4 6/7		K00
90833-5001	9	NATURAL	1b 2a 3a 5a 6d 7b 8b	01c 03c d70 08c d90	3/4 6/7		K34
90833-5010	9	NATURAL	2b 5a	d80	2/3 7/8		K03
90833-5012	9	NATURAL	1b	03c	5/6		K0A

MOLEX PART NO	CIRCUIT SIZE	COLOUR	POSITION KEYS	CODING KEYS	LATCH POSITION	CONFIGURATION	REF
90833-8000	12	NATURAL	ALL	ALL	3/4 9/10		K00
90833-8001	12	NATURAL	1a 2a 4a 4b 5a 6b 8a 11a	01c 03c 05c 07c d80 d10 11c	3/4 9/10		K41

90833-6000	10	NATURAL	ALL	ALL	3/4 7/8		K00
90833-6001	10	NATURAL	1a 3b 7b 8a	01c d20 d40 05c d100	3/4 7/8		K34
90833-6005	10	NATURAL	ALL	ALL	4/5 7/8		K98
90833-6006	10	NATURAL	ALL	ALL	4/5 6/7		K99
90833-6007	10	NATURAL	1a 10b	07c	4/5 7/8		K39
90833-6008	10	NATURAL	1b 9a	06c	4/5 6/7		K40
90833-6023	10	NATURAL	1b	03c	5/6		
90833-6024	10	NATURAL	4b 6b 8a 8b	d100	5/6		K**
90833-6025	10	NATURAL	4b 6b 8a 8b	06c d100	NONE		K**

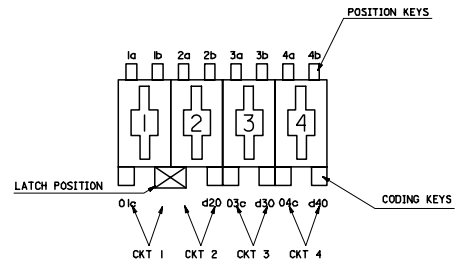

KEYING, CODING & LATCH IDENTIFICATION
(4 CKT EXAMPLE SHOWN)
VIEW IN MATING DIRECTION

MOLEX PART NO	CIRCUIT SIZE	COLOUR	POSITION KEYS	CODING KEYS	LATCH POSITION	CONFIGURATION	REF
90833-7000	11	NATURAL	ALL	ALL	3/4 8/9		K00
90833-7001	11	NATURAL	1a 2b 3b 4a 4b 5a 7a 8a 9a 10a 11a	01c d40 05c 08c 10c	3/4 8/9		K33

UPDATED TO ANNON EEC NO: E2007-0946 DRAWN: BRUTTILE 2007/11/07 CHKD: 2007/11/21 APPR: BMAGUIRE 2007/11/21 REV: AB	QUALITY SYMBOLS ▽=0 ▽=0	GENERAL TOLERANCES (UNLESS SPECIFIED) 4 PLACES ± --- ± --- 3 PLACES ± 0.025 ± --- 2 PLACES ± 0.05 ± --- 1 PLACE ± 0.1 ± --- ANGULAR ± 1/2°	DIMENSION STYLE MM ONLY DRAWN BY DATE PC 94/02/14 CHECKED BY DATE BMAGUIRE 94/02/14 APPROVED BY DATE MWILHITE 94/02/14 MATERIAL NO. DOCUMENT NO.	SCALE 1:1 DESIGN UNITS METRIC THIRD ANGLE PROJECTION TITLE 5MM APPLI-MATE 6A/10A F-INDIRECT CONN ASSY
	DRAFT WHERE APPLICABLE MUST REMAIN WITHIN DIMENSIONS		SEE CHARTS	MOLEX INCORPORATED SD-90833-001
	THIS DRAWING CONTAINS INFORMATION THAT IS PROPRIETARY TO MOLEX INCORPORATED AND SHOULD NOT BE USED WITHOUT WRITTEN PERMISSION		SIZE A2	SHEET NO. 6 OF 6