

BACKPLANE HOLE PATTERN (COMPONENT SIDE-10 POS SHOWN)

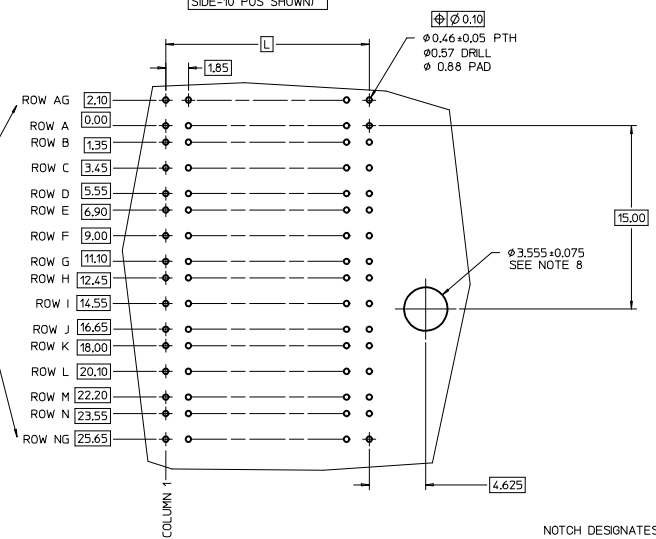

ROW AG & NG RECOMMENDED FOR ALL APPLICATIONS. THESE ROWS SHOULD BE CONNECTED TO GROUND.

THE PRIMARY CARTON WITH A LABEL STATING "ELV AND RoHS COMPLAINT" IS LEAD FREE. CARTONS WITHOUT THIS LABEL MAY CONTAIN LEAD.

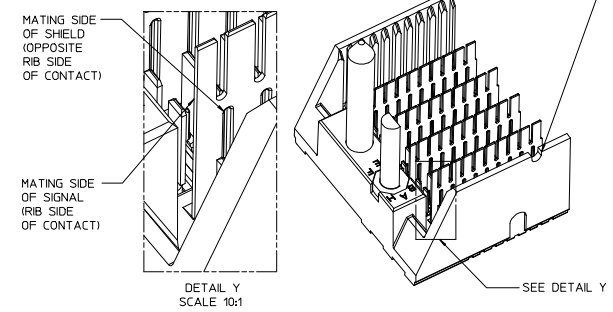
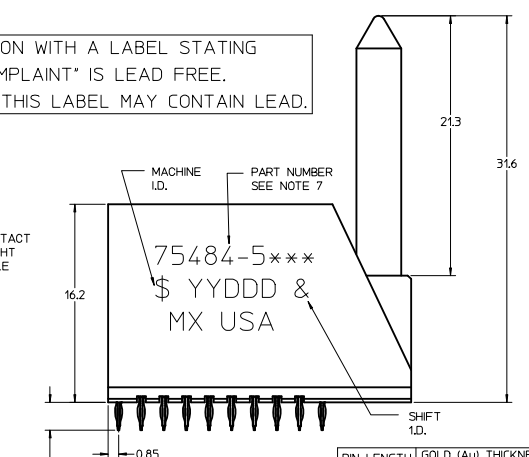
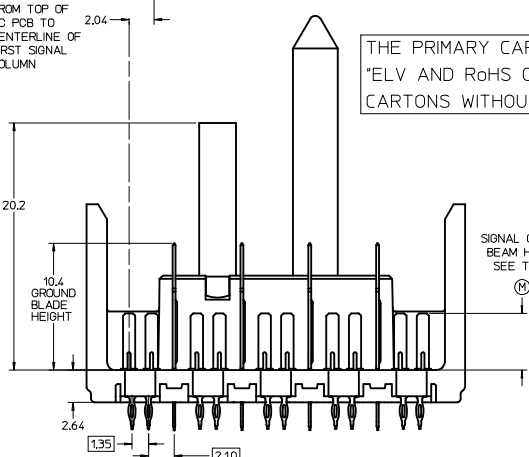

LEAD-FREE PLATING

- NOTES:
1. MATERIAL: HOUSING - LIQUID CRYSTAL POLYMER (LCP) GLASS-FILLED, UL 94V-0, COLOR - GRAY, ELECTRICALLY ENHANCED INSERT - CONDUCTIVE RESIN, COLOR - BLACK, SIGNAL CONTACT AND GROUND BLADE - HIGH PERFORMANCE COPPER ALLOY.
 2. FINISHES: SELECTIVE GOLD (Au) ON CONTACT AREA, SELECTIVE MATTE TIN (Sn) ON PCB TAILS, NICKEL (Ni) OVERALL.
 3. THIS PART CONFORMS TO MOLEX PRODUCT SPECIFICATION PS-75221-999.
 4. FOR MIXED CONTACT MATING LENGTHS CONSULT MOLEX FOR AVAILABILITY. CONTACT PAIRS MUST BE THE SAME LENGTH.
 5. FOR SPECIFIC PART NUMBER AND MATING INFORMATION PLEASE REFER TO CHART.
 6. PACKAGE PER PK-70873-565.
 7. EITHER MARK PART NUMBER AND DATE CODE APPROXIMATELY WHERE SHOWN, ON EITHER SIDE OF THE PART, OR PLACE A LABEL ON THE TUBE.
 8. OPTIONAL HOLE LOCATION FOR GROUNDED GUIDE PIN OR ADDITIONAL GUIDE PIN SUPPORT. SEE DRAWING SD-75234-100 FOR DETAIL & LOCATION.
 9. MINIMUM BOARD THICKNESS: 1.6
 10. THESE PARTS CONFORM TO MOLEX COSMETIC SPECIFICATION PS-45499-002 CLASS B.
 11. MAPS (MOLEX ADVANCED PLATING SYSTEM).

PIN LENGTH DIM 'M'	GOLD (Au) THICKNESS micrometers
0=3.55 mm	0.25 (MAPS)
1=4.55 mm	
2=5.55 mm	
3=3.55 mm	0.76
4=4.55 mm	
5=5.55 mm	
7=3.55 mm	1.27
8=4.55 mm	
9=5.55 mm	

75484-5***
COLUMN
51 = 10 COL
52 = 25 COL
KEYING ORIENTATION (SEE TABLE)

ASSY PART NO.	K	L	P	TOTAL NO. OF DIFFERENTIAL PAIRS
75848-51**	9	16.65	24.78	50
75848-52**	24	44.40	52.53	125

P/N	---0*	---1*	---2*	---3*	---4*	---5*	---6*	---7*	---8*
75848-()	0	A	B	C	D	E	F	G	H
KEYING PIN ORIENTATION									

REV TO LEAD-FREE EC NO: UCP 2013-1905 DRAWINGS: 2012/09/07 CHKD: MOLEFE 2012/09/07 APPR: MILLER 2012/12/05 REV DESCRIPTION	QUALITY SYMBOLS ∇=0 ∇=0 ∇=0	GENERAL TOLERANCES (UNLESS SPECIFIED) DIMENSION STYLE: MM ONLY SCALE: 5:1 DESIGN UNITS: METRIC THIRD ANGLE PROJECTION	DRAWN BY: JBLINGHAM CHECKED BY: JL LAURX APPROVED BY: SMILLER DATE: 2008/01/28 DATE: 2008/01/28 DATE: 2012/12/05	TITLE: GBX 5-PAIR BACKPLANE LF ELECTRICALLY ENHANCED RIGHT END SALES ASSEMBLY molex DOCUMENT NO: SD-75848-510 SHEET NO: 1 OF 1
	DRAFT WHERE APPLICABLE MUST REMAIN WITHIN DIMENSIONS	ANGULAR ±1/2°	MATERIAL NO: SEE CHART	THIS DRAWING CONTAINS INFORMATION THAT IS PROPRIETARY TO MOLEX INCORPORATED AND SHOULD NOT BE USED WITHOUT WRITTEN PERMISSION