

- NOTES:
- MATERIAL:
HOUSING: GLASS FILLED LCP (LIQUID CRYSTAL POLYMER), UL94V-0; COLOR: BLACK
POWER CONTACT: COPPER ALLOY
SIGNAL CONTACT: PHOSPHOR BRONZE
 - FINISH: SELECT GOLD 0.76 MICROMETER/30 MICORINCH MINIMUM;
SELECT TIN 3.81 MICROMETER/150 MICORINCH MINIMUM;
BOTH OVER NICKEL 1.27 MICROMETER/50 MICORINCH MINIMUM.
 - PRODUCT SPECIFICATION: PS-45984-001
 - PACKAGING SPECIFICATION: TRAY PER PK-45984-001.
 - SEE SHEET 5 FOR CIRCUIT IDENTIFICATION.
 - PARTS ARE RoHS COMPLIANT.
 - PEG HOLES ARE OPTIONAL PCB FEATURES AND ARE REQUIRED ONLY WITH THE PEGGED OPTIONS.
 - MATES WITH MOLEX RECEPTACLE SERIES 45984-4***.

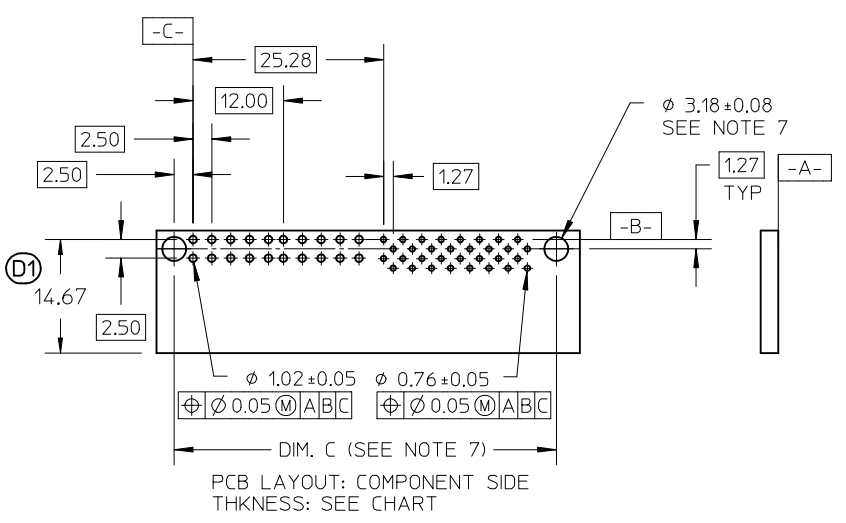

NO OF SIGNAL	MATERIAL NUMBER	DIM A REF	DIM P	PCB THK
12	45985-4111	36.16	4.50	3.18
16	45985-4121	38.70		
20	45985-4131	41.24		
24	45985-4141	43.78		
28	45985-4151	46.32		
32	45985-4161	48.86		
36	45985-4171	51.40		
40	45985-4181	53.94		
12	45985-4112	36.16	3.90	2.36
16	45985-4122	38.70		
20	45985-4132	41.24		
24	45985-4142	43.78		
28	45985-4152	46.32		
32	45985-4162	48.86		
36	45985-4172	51.40		
40	45985-4182	53.94		
12	45985-4113	36.16	2.90	1.57
16	45985-4123	38.70		
20	45985-4133	41.24		
24	45985-4143	43.78		
28	45985-4153	46.32		
32	45985-4163	48.86		
36	45985-4173	51.40		
40	45985-4183	53.94		

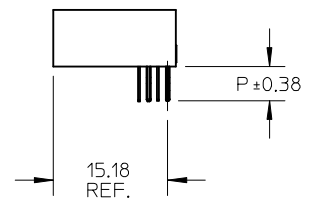
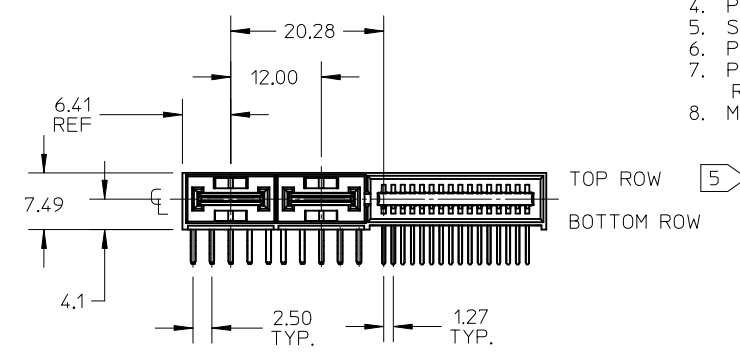
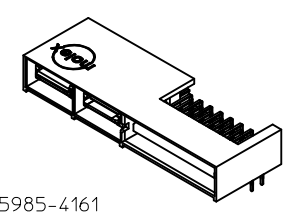

45985-4161
(SHOWN FOR REFERENCE)
SEE CHART

ADD DIMENSION	DESCRIPTION
EC NO: UCP2015-3913	
DRWN: JUILLES 2015/03/24	
CHKD: MBANDURA 2015/03/24	
APPR: APATEL 2015/04/09	
D1	REV

GENERAL TOLERANCES (UNLESS SPECIFIED)		
	mm	INCH
4 PLACES	± ---	± ---
3 PLACES	± ---	± ---
2 PLACES	± 0.25	± ---
1 PLACE	± ---	± ---
ANGULAR ± 1/2°		
DRAFT WHERE APPLICABLE MUST REMAIN WITHIN DIMENSIONS		

DIMENSION STYLE	
MM ONLY	
DRAWN BY	DATE
JSCHAFFER	6-10-05
CHECKED BY	DATE
YMARGULIS	6-14-05
APPROVED BY	DATE
YMARGULIS	6-15-05
MATERIAL NO.	
SEE CHART	
SIZE	
A	

SCALE	DESIGN UNITS	THIRD ANGLE PROJECTION	
1:1	METRIC		
TITLE			
LPH PLUG ASSEMBLY RT ANGLE 4 CIRCUIT POWER CONNECTOR			
molex MOLEX INCORPORATED			
DOCUMENT NO.			SHEET NO.
SD-45985-400			1 OF 5
THIS DRAWING CONTAINS INFORMATION THAT IS PROPRIETARY TO MOLEX INCORPORATED AND SHOULD NOT BE USED WITHOUT WRITTEN PERMISSION			

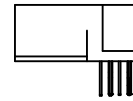
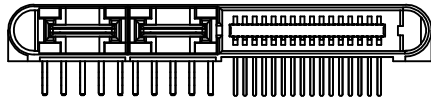
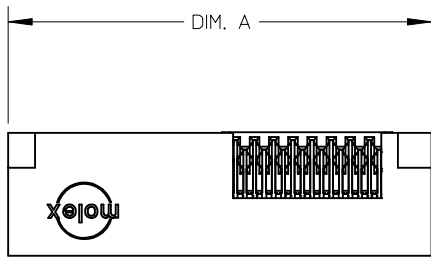

GUIDE OPTIONS

NO OF SIGNAL	MATERIAL NUMBER	DIM A REF	DIM P	PCB THK
12	45985-4211	43.66	4.50	3.18
16	45985-4221	46.20		
20	45985-4231	48.74		
24	45985-4241	51.28		
28	45985-4251	53.82		
32	45985-4261	56.36		
36	45985-4271	58.90	3.90	2.36
40	45985-4281	61.44		
12	45985-4212	43.66		
16	45985-4222	46.20		
20	45985-4232	48.74		
24	45985-4242	51.28		
28	45985-4252	53.82	2.90	1.57
32	45985-4262	56.36		
36	45985-4272	58.90		
40	45985-4282	61.44		
12	45985-4213	43.66		
16	45985-4223	46.20		
20	45985-4233	48.74	2.90	1.57
24	45985-4243	51.28		
28	45985-4253	53.82		
32	45985-4263	56.36		
36	45985-4273	58.90		
40	45985-4283	61.44		

NOTE:
1. SEE SHEET 1 FOR DIMENSIONS NOT SHOWN.

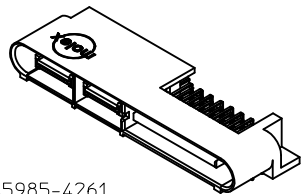

45985-4261
(SHOWN FOR REFERENCE)
SEE CHART

SEE SHEET 1 EC NO: UCP2015-3913 DRWN: JUILLES 2015/03/24 CHKD: MBANDURA 2015/03/24 APPR: APATEL 2015/04/09	DESCRIPTION	GENERAL TOLERANCES (UNLESS SPECIFIED)		DIMENSION STYLE MM ONLY		SCALE 1:1	DESIGN UNITS METRIC	THIRD ANGLE PROJECTION	
			mm	INCH	DRAWN BY JSCHAFFER	DATE 6-10-05	TITLE LPH PLUG ASSEMBLY RT ANGLE 4 CIRCUIT POWER CONNECTOR		
	4 PLACES	± ---	± ---	CHECKED BY YMARGULIS	DATE 6-14-05	MOLEX INCORPORATED			
	3 PLACES	± ---	± ---	APPROVED BY YMARGULIS	DATE 6-15-05				
	2 PLACES	± 0.25	± ---	MATERIAL NO. SEE CHART		SHEET NO. 2 OF 5			
	1 PLACE	± ---	± ---	SIZE A					
		ANGULAR ±1/2°		DRAFT WHERE APPLICABLE MUST REMAIN WITHIN DIMENSIONS					

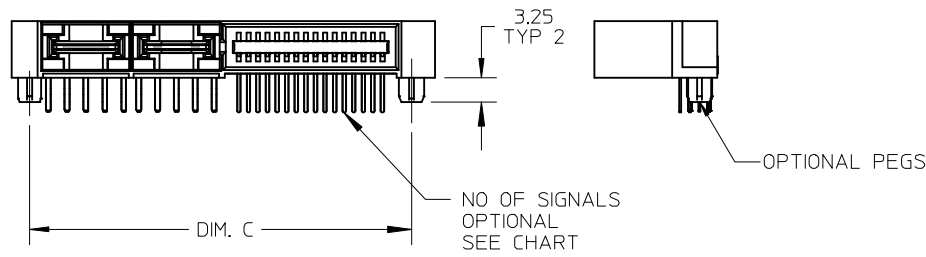
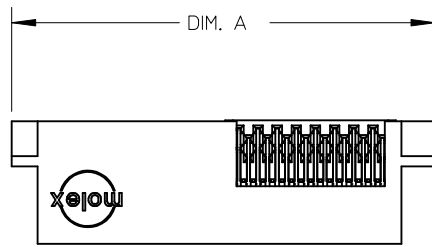

MOUNTING PEG OPTIONS

NO OF SIGNAL	MATERIAL NUMBER	DIM A REF	DIM C	DIM P	PCB THK
12	45985-4311	43.66	37.98	4.50	3.18
16	45985-4321	46.20	40.52		
20	45985-4331	48.74	43.06		
24	45985-4341	51.28	45.60		
28	45985-4351	53.82	48.14		
32	45985-4361	56.36	50.68		
36	45985-4371	58.90	53.22	3.90	2.36
40	45985-4381	61.44	55.76		
12	45985-4312	43.66	37.98		
16	45985-4322	46.20	40.52		
20	45985-4332	48.74	43.06		
24	45985-4342	51.28	45.60		
28	45985-4352	53.82	48.14		
32	45985-4362	56.36	50.68		
36	45985-4372	58.90	53.22		
40	45985-4382	61.44	55.76	2.90	1.57
12	45985-4313	43.66	37.98		
16	45985-4323	46.20	40.52		
20	45985-4333	48.74	43.06		
24	45985-4343	51.28	45.60		
28	45985-4353	53.82	48.14		
32	45985-4363	56.36	50.68		
36	45985-4373	58.90	53.22		
40	45985-4383	61.44	55.76		

NOTE:
1. SEE SHEET 1 FOR DIMENSIONS NOT SHOWN.

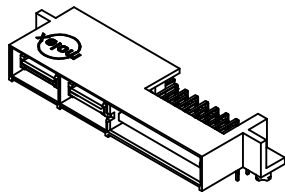

45985-4361
(SHOWN FOR REFERENCE)
SEE CHART

SEE SHEET 1 EC NO: UCP2015-3913 DRWN: JOULES 2015/03/24 CHKD: MBANDURA 2015/03/24 APPR: APATEL 2015/04/09	DESCRIPTION	GENERAL TOLERANCES (UNLESS SPECIFIED)		DIMENSION STYLE MM ONLY		SCALE 1:1	DESIGN UNITS METRIC	THIRD ANGLE PROJECTION		
			mm	INCH	DRAWN BY JSCHAFFER	DATE 6-10-05	TITLE LPH PLUG ASSEMBLY RT ANGLE 4 CIRCUIT POWER CONNECTOR			
		4 PLACES	± ---	± ---	CHECKED BY YMARGULIS	DATE 6-14-05				
		3 PLACES	± ---	± ---	APPROVED BY YMARGULIS	DATE 6-15-05	MOLEX INCORPORATED			
2 PLACES	± 0.25	± ---	ANGULAR ±1/2°		MATERIAL NO. SEE CHART	DOCUMENT NO. SD-45985-400	SHEET NO. 3 OF 5			
1 PLACE	± ---	± ---	DRAFT WHERE APPLICABLE MUST REMAIN WITHIN DIMENSIONS		SIZE A	THIS DRAWING CONTAINS INFORMATION THAT IS PROPRIETARY TO MOLEX INCORPORATED AND SHOULD NOT BE USED WITHOUT WRITTEN PERMISSION				

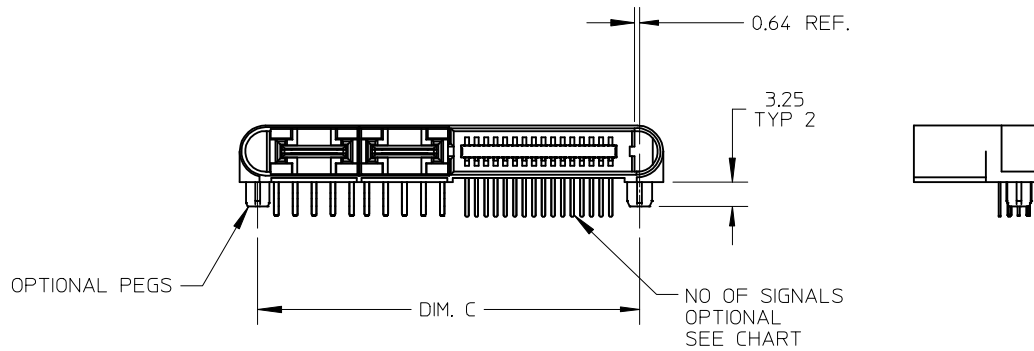
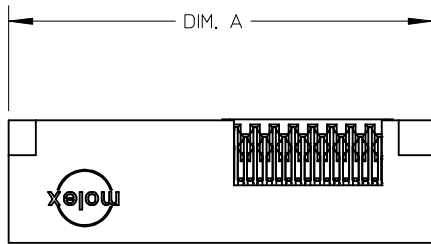

GUIDE & MOUNTING PEG OPTIONS

NO OF SIGNAL	MATERIAL NUMBER	DIM A REF	DIM C	DIM P	PCB THK
12	45985-4411	43.66	37.98	4.50	3.18
16	45985-4421	46.20	40.52		
20	45985-4431	48.74	43.06		
24	45985-4441	51.28	45.60		
28	45985-4451	53.82	48.14		
32	45985-4461	56.36	50.68		
36	45985-4471	58.90	53.22	3.90	2.36
40	45985-4481	61.44	55.76		
12	45985-4412	43.66	37.98		
16	45985-4422	46.20	40.52		
20	45985-4432	48.74	43.06		
24	45985-4442	51.28	45.60		
28	45985-4452	53.82	48.14		
32	45985-4462	56.36	50.68		
36	45985-4472	58.90	53.22	2.90	1.57
40	45985-4482	61.44	55.76		
12	45985-4413	43.66	37.98		
16	45985-4423	46.20	40.52		
20	45985-4433	48.74	43.06		
24	45985-4443	51.28	45.60		
28	45985-4453	53.82	48.14		
32	45985-4463	56.36	50.68		
36	45985-4473	58.90	53.22		
40	45985-4483	61.44	55.76		

NOTE:
1. SEE SHEET 1 FOR DIMENSIONS NOT SHOWN.

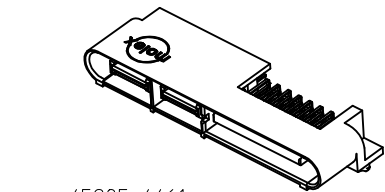

45985-4461
(SHOWN FOR REFERENCE)
SEE CHART

SEE SHEET 1 EC NO: UCP2015-3913 DRWN: JUILLES 2015/03/24 CHKD: MBANDURA 2015/03/24 APPR: APATEL 2015/04/09	DESCRIPTION	GENERAL TOLERANCES (UNLESS SPECIFIED)		DIMENSION STYLE MM ONLY		SCALE 1:1	DESIGN UNITS METRIC	THIRD ANGLE PROJECTION		
			mm	INCH	DRAWN BY JSCHAFFER	DATE 6-10-05	TITLE LPH PLUG ASSEMBLY RT ANGLE 4 CIRCUIT POWER CONNECTOR			
		4 PLACES	± ---	± ---	CHECKED BY YMARGULIS	DATE 6-14-05				
		3 PLACES	± ---	± ---	APPROVED BY YMARGULIS	DATE 6-15-05	MOLEX INCORPORATED			
2 PLACES	± 0.25	± ---	ANGULAR ±1/2°		MATERIAL NO. SEE CHART	DOCUMENT NO. SD-45985-400	SHEET NO. 4 OF 5			
1 PLACE	± ---	± ---	DRAFT WHERE APPLICABLE MUST REMAIN WITHIN DIMENSIONS		SIZE A	THIS DRAWING CONTAINS INFORMATION THAT IS PROPRIETARY TO MOLEX INCORPORATED AND SHOULD NOT BE USED WITHOUT WRITTEN PERMISSION				

CIRCUIT NUMBERING SYSTEM

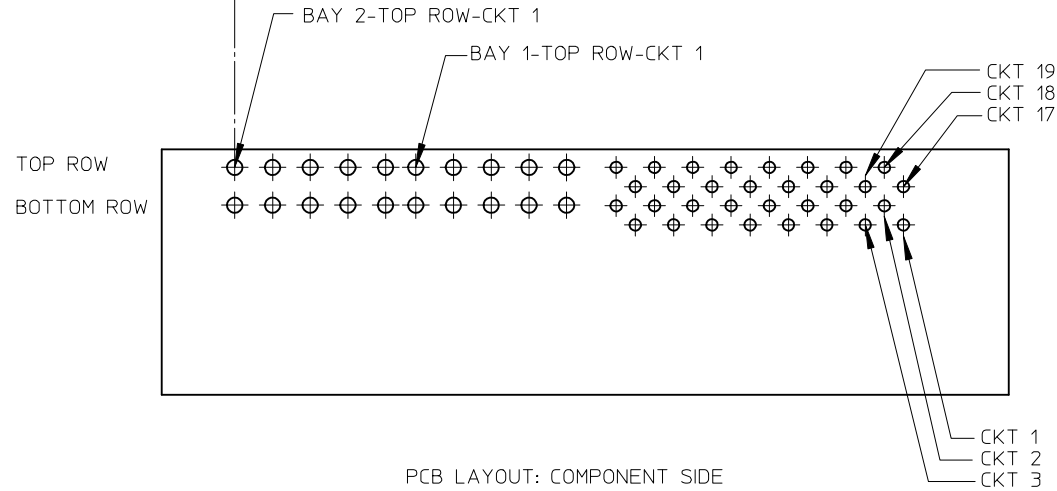
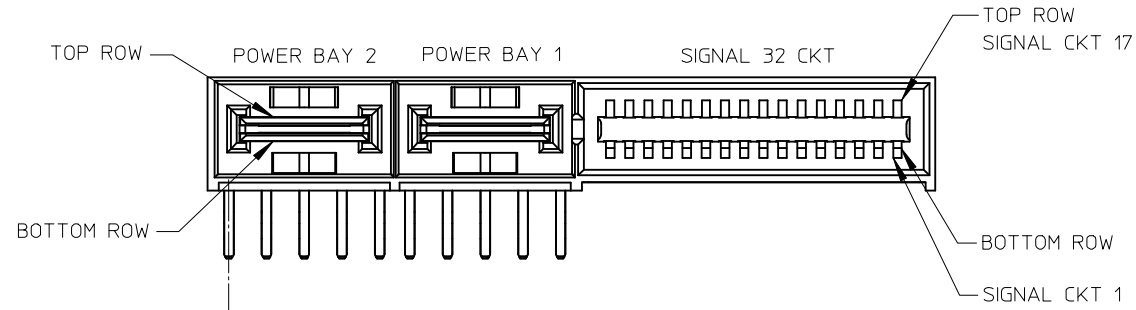

SEE SHEET 1 EC NO: UCP2015-3913 DRWN: JOUILLES 2015/03/24 CHKD: MBANDURA 2015/03/24 APPR: APATEL 2015/04/09	DESCRIPTION	GENERAL TOLERANCES (UNLESS SPECIFIED)		DIMENSION STYLE MM ONLY		SCALE 2:1	DESIGN UNITS METRIC	THIRD ANGLE PROJECTION	
			mm	INCH	DRAWN BY JSCHAFFER	DATE 6-10-05	TITLE LPH PLUG ASSEMBLY RT ANGLE 4 CIRCUIT POWER CONNECTOR		
		4 PLACES	± ---	± ---	CHECKED BY YMARGULIS	DATE 6-14-05			
		3 PLACES	± ---	± ---	APPROVED BY YMARGULIS	DATE 6-15-05	MOLEX INCORPORATED DOCUMENT NO. SD-45985-400 SHEET NO. 5 OF 5		
		2 PLACES	± 0.25	± ---	MATERIAL NO. SEE CHART				
1 PLACE	± ---	± ---	ANGULAR ±1/2°		DRAFT WHERE APPLICABLE MUST REMAIN WITHIN DIMENSIONS		THIS DRAWING CONTAINS INFORMATION THAT IS PROPRIETARY TO MOLEX INCORPORATED AND SHOULD NOT BE USED WITHOUT WRITTEN PERMISSION		
D1	REV								