

REF. -50 OPT. SCREW
(WHERE APPLICABLE)

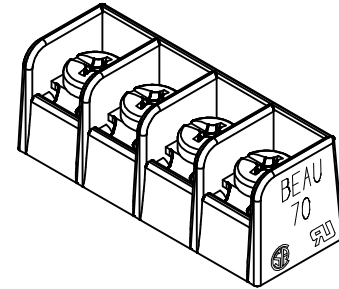

4 CIRCUIT SHOWN

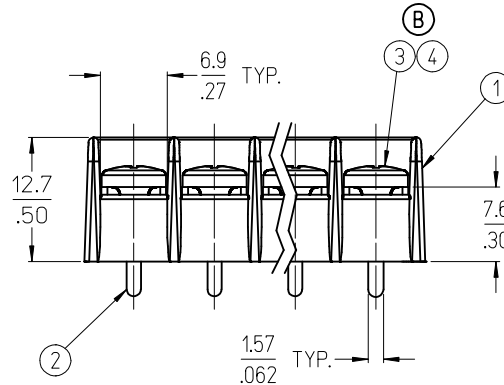
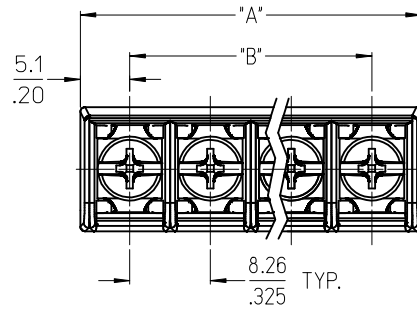
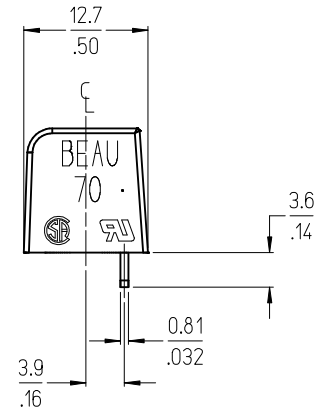

NOTES:

1. MATERIAL: SEE TABLE
2. FINISHES: SEE TABLE
3. "XX" REFERS TO THE QUANTITY OF CIRCUITS
4. ROHS COMPLIANT

5	XX	SCREW&WASHER, #6-32X.25, PAN, PH/SL (-50 OPT)	STEEL	ZN, CLEAR CHROMATE
4	XX	SCREW, #6-32X.25, PAN, PH/SL (-49 OPT)	BRASS	NICKEL PLATE
3	XX	SCREW, #6-32X.25, PAN, PH/SL (STD.)	STEEL	ZN, CLEAR CHROMATE
2	XX	TERMINAL, PC	BRASS	TIN PLATE
1	1	INSULATOR, SR BTS PC CS 2 MO C	POLYESTER (PBT)	BLACK
ITEM	QTY.	DESCRIPTION	MATERIAL	FINISH

ADD STD AND -49 OPT
EC NO: MNA2009-0702
DRAWN: JENC INAS 2009/05/26
CHKD: CYORK 2009/05/27
APPR: JIMAGNE ILI 2009/05/27

QUALITY SYMBOLS
▽=0
▽=0

GENERAL TOLERANCES (UNLESS SPECIFIED)

	mm	INCH
4 PLACES	± .005	± .0005
3 PLACES	± .01	± .001
2 PLACES	± .013	± .0013
1 PLACE	± 0.3	± .0118

ANGULAR ± 2 °

DRAFT WHERE APPLICABLE
MUST REMAIN
WITHIN DIMENSIONS

DIMENSION STYLE
MM/IN

DRAWN BY DATE
R. KEMP 2003/05/16

CHECKED BY DATE
P. WALTZ 2003/05/22

APPROVED BY DATE
P. WALTZ 2003/05/22

MATERIAL NO.

SCALE 2:1

DESIGN UNITS INCH

THIRD ANGLE PROJECTION

8.26MM [.325] SR BTS, CS
PC, NO MTG. ENDS

MOLEX INCORPORATED

DOCUMENT NO. SD-38704-001

SHEET NO. 1 OF 2

THIS DRAWING CONTAINS INFORMATION THAT IS PROPRIETARY TO MOLEX INCORPORATED AND SHOULD NOT BE USED WITHOUT WRITTEN PERMISSION

10 9 8 7 6 5 4 3 2 1

NO. OF CIRCUITS	DIM. "A"		DIM. "B"		ASSEMBLY MATERIAL NO. (STANDARD)	ASSEMBLY MATERIAL NO. (-49 OPT)	ASSEMBLY MATERIAL NO. (-50 OPT)
	mm	in	mm	in			
02	18.5	0.73	8.26	.325	387044102	387044502	387044902
03	26.8	1.06	16.51	.650	387044103	387044503	387044903
04	35.1	1.38	24.77	.975	387044104	387044504	387044904
05	43.3	1.70	33.02	1.300	387044105	387044505	387044905
06	51.5	2.03	41.28	1.625	387044106	387044506	387044906
07	59.8	2.35	49.53	1.950	387044107	387044507	387044907
08	68.0	2.68	57.79	2.275	387044108	387044508	387044908
09	76.3	3.00	66.04	2.600	387044109	387044509	387044909
10	84.6	3.33	74.30	2.925	387044110	387044510	387044910
11	92.8	3.65	82.55	3.250	387044111	387044511	387044911
12	101.1	3.98	90.81	3.575	387044112	387044512	387044912
13	109.3	4.30	99.06	3.900	387044113	387044513	387044913
14	117.6	4.63	107.32	4.225	387044114	387044514	387044914
15	125.8	4.95	115.57	4.550	387044115	387044515	387044915
16	134.1	5.28	123.83	4.875	387044116	387044516	387044916

SEE SHEET ONE EC NO: WNA2009-0702 DRWN: JENC INAS 2009/05/26 CHKD: CYORK 2009/05/27 APPR: JMACNE IL 2009/05/27	QUALITY SYMBOLS	GENERAL TOLERANCES (UNLESS SPECIFIED)	DIMENSION STYLE	SCALE	DESIGN UNITS	THIRD ANGLE PROJECTION
	▼=0 ▽=0	mm	MM/IN	1:1	INCH	8.26MM [.325] SR BTS, CS PC, NO MTG. ENDS
		INCH				
	B	DESCRIPTION	4 PLACES ± --- ± --- 3 PLACES ± --- ± .005 2 PLACES ± 0.13 ± .01 1 PLACE ± 0.3 ± --- ANGULAR ± 2 °	DRAWN BY DATE R. KEMP 2003/05/16 CHECKED BY DATE P. WALTZ 2003/05/22 APPROVED BY DATE P. WALTZ 2003/05/22	TITLE MOLEX INCORPORATED	
REV		DRAFT WHERE APPLICABLE MUST REMAIN WITHIN DIMENSIONS	MATERIAL NO. SEE CHART	DOCUMENT NO. SD-38704-001		

9 8 7 6 5 4 3 2 1