

DWG. NO.
SD-56377-015

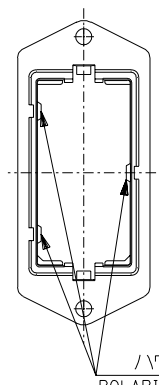

ハウジング挿入方向キー
POLARIZATIONS KEY FOR HOUSING

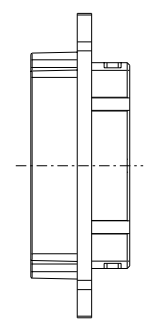
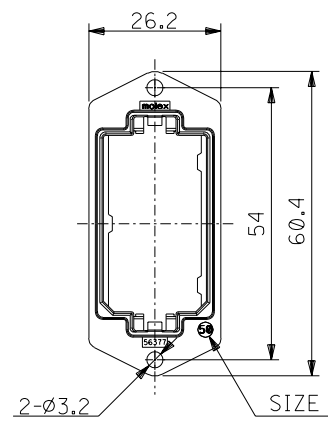
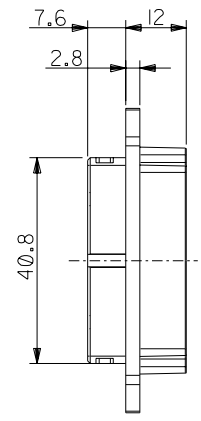

推奨パネル切り取り寸法 (前面取り付け)
RECOMMENDED PANEL OPENING (FRONT MOUNTING)

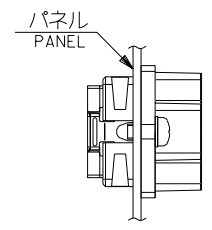
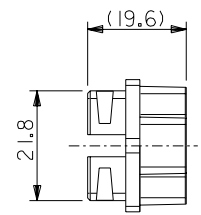

パネル前面取り付け
FRONT MOUNT TYPE

注記
NOTES

- 材質
MATERIAL
亜鉛合金, ニッケルメッキ
ZINC ALLOY, NI PLATING
- 適用ハウジングアッセンブリ: 51233-501* (PIN HS'G ASS'Y)
51238-501* (SOCKET HS'G ASS'Y)
APPLICABLE HOUSING ASS'Y: 51233-501* (PIN HS'G ASS'Y)
51238-501* (SOCKET HS'G ASS'Y)
- 推奨ねじ締め付けトルク: 5~6 kgf・cm
RECOMMENDED SCREW TIGHTENING TORQUE: 5~6 kgf・cm

56377-5000	56377-****
MATERIAL NO.	MODEL NO.

DO NOT SCALE DRAWING

EC NO. DRWN: CHK: APPR:	EC NO. DRWN: CHK: APPR:	EC NO. DRWN: CHK: APPR:	REVISED '02/06/03	MATERIAL 材料	GENERAL TOLERANCES: (UNLESS SPECIFIED) 一般公差	SCALE	DESIGN UNITS <input checked="" type="checkbox"/> mm <input type="checkbox"/> INCH	THIRD ANGLE PROJECTION	DIMENSIONS: <input type="checkbox"/> mm <input type="checkbox"/> INCH <input checked="" type="checkbox"/> mm ONLY	SHT	REV
			EC NO. J2002-3016 DRWN: S.AKIYAMA CHK: J.MIYAZAWA APPR: YO.IITO								
A	Ø	Ø	RELEASED '02/02/04	注記参照 SEE NOTES	30 UNDER 未満	±0.25	CHECKED BY & DATE <i>J. Mizuno</i> '02/02/04	MATERIAL NO.	DRAWING NO.	SHEET NO.	REV
			EC NO. J2002-1828 DRWN: S.AKIYAMA CHK: J.MIYAZAWA APPR: YO.IITO								
WIRE RANGE 適用線径範囲	INS. RANGE 被覆外径	ANGLE 角度	±3°	CAD FILENAME 56377015.S01	MATERIAL NO. SEE CHART	DRAWING NO. SD-56377-015	SHEET NO. 1 OF 1	THIS DRAWING CONTAINS INFORMATION THAT IS PROPRIETARY TO MOLEX INCORPORATED AND SHOULD NOT BE USED WITHOUT WRITTEN PERMISSION.		SIZE B	