

NOTES:

- 1- MATERIAL: PA 6.6 BLACK heat stabilized.
- 2- DELIVERED PRODUCT WEIGHT: 3.6 g.
- 3- RELATED COUNTERPART FEMALE CONNECTORS (32 WAYS).

MARKINGS:

1 Supplier identification.

3 Date: MONTH/YEAR.

4 Material.

5 Mould identification M1 or M2.

6 Print identification (number).

7 Revision level

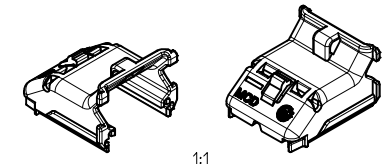
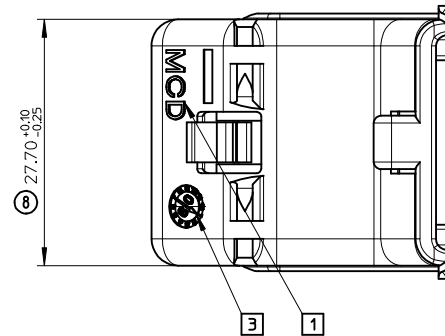
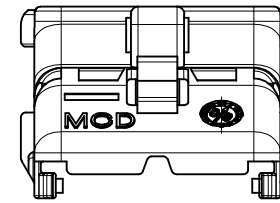
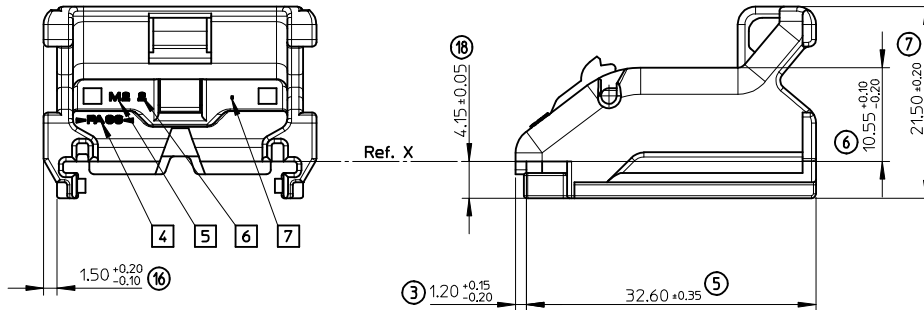

REVISED EC NO: G2015-0147 DRW: PBOUAIN 2015/02/12 CHKD: APLESSIS 2015/02/12 APPR: CBOUCHAN 2015/03/03	DESCRIPTION	GENERAL TOLERANCES (UNLESS SPECIFIED)		DIMENSION STYLE	SCALE	DESIGN UNITS	FIRST ANGLE PROJECTION	
				MM ONLY	2.5:1	METRIC		
		4 PLACES	± ---	± ---	DRAWN BY	DATE	TITLE	
		3 PLACES	± ---	± ---	PGRANDCL	2013/04/15	WIRE CAP 32 WAY MAT SEAL VERSION	
			2 PLACES	± ---	± ---	CHECKED BY	DATE	
			1 PLACE	± ---	± ---	JDUCLOS	2013/04/15	
			0 PLACE	± ---	± ---	APPROVED BY	DATE	
						CBOUCHAN	2014/02/03	
			ANGULAR ± ---°		MATERIAL NO.	DOCUMENT NO.		
			DRAFT WHERE APPLICABLE MUST REMAIN WITHIN DIMENSIONS		0643191201	SD-64319-002	SHEET NO. 1 OF 1	
			SIZE A2		THIS DRAWING CONTAINS INFORMATION THAT IS PROPRIETARY TO MOLEX INCORPORATED AND SHOULD NOT BE USED WITHOUT WRITTEN PERMISSION			