

DWG. NO. SD-1854\*

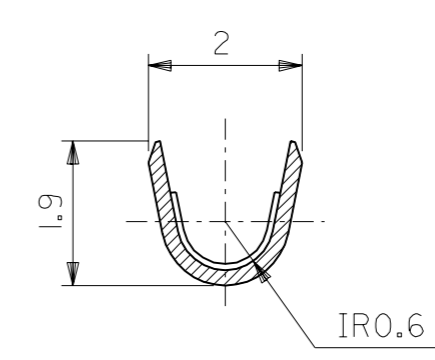

SECT. A-A  
(SCALE 10 : 1)

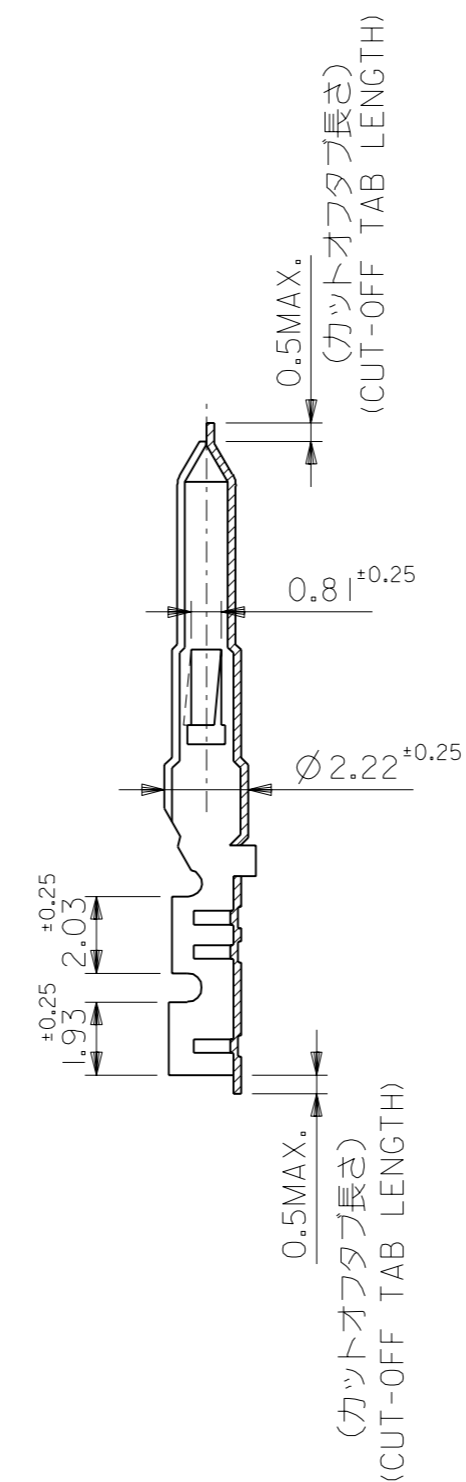
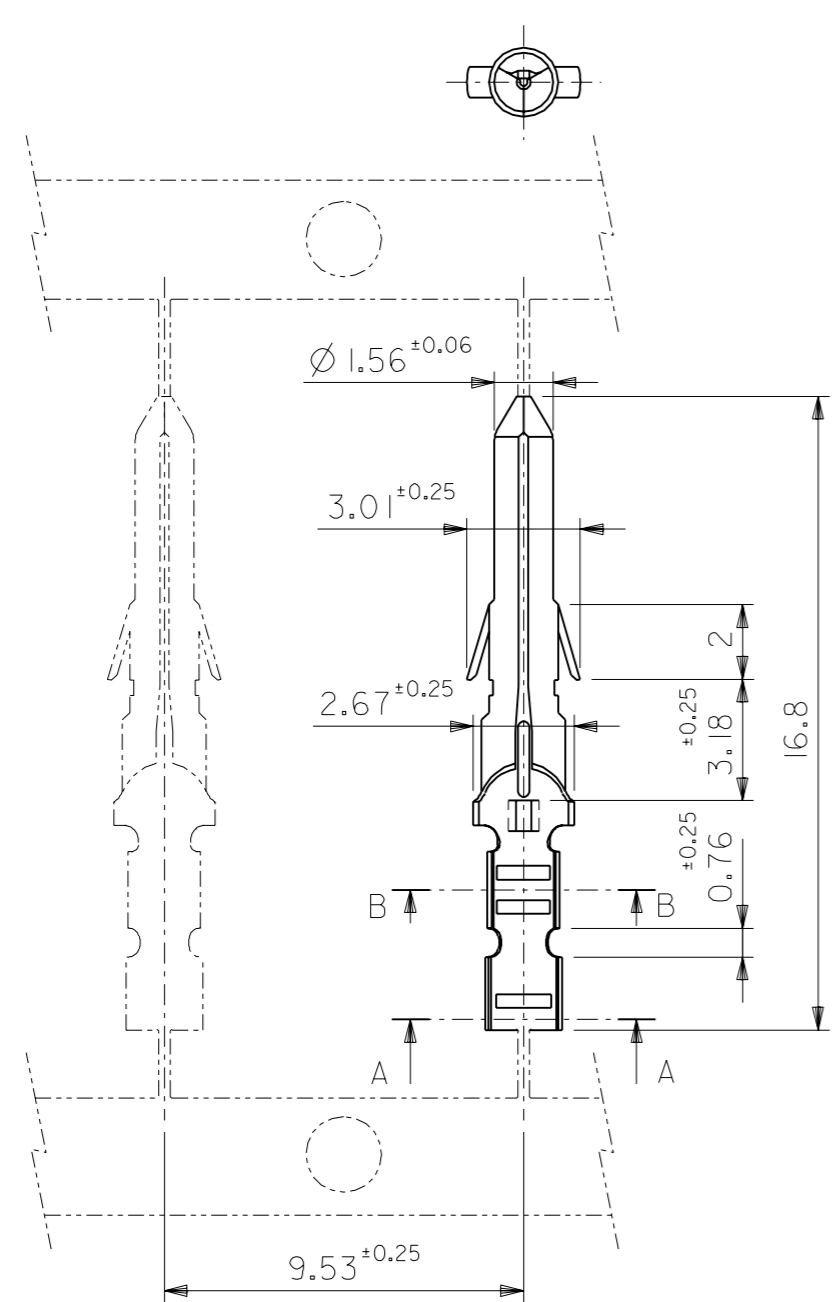
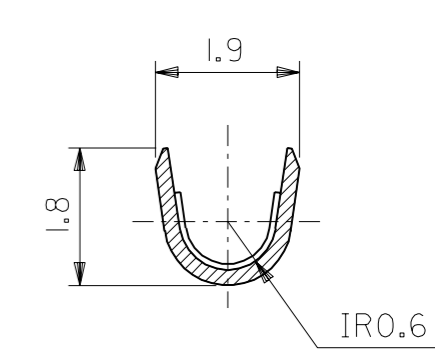

SECT. B-B  
(SCALE 10 : 1)

注記 NOTES:  
1. 一般公差 : ±0.4  
GENERAL TOLERANCES: ±0.4

ニッケル (2 µm MIN.) 下地 金 (0.35 µm MIN.) GOLD (0.35 µm MIN.) OVER NICKEL (2 µm MIN.)	39-00-0337	1854GL	バラ端子 LOOSE
銅 (0.5 µm MIN.) 下地 錫 (0.9 µm MIN.) TIN (0.9 µm MIN.) OVER COPPER (0.5 µm MIN.)	39-00-0336	1854G	連鎖状端子 CHAIN
メッキ PLATING	EDP.NO.	ENG.NO.	形状 FORM

材料 MATERIAL 黄銅 BRASS 0.2 t	MOLEX-JAPAN CO.,LTD. 日本モレックス株式会社
仕上げ FINISH	REVISE ONLY ON CAD SYSTEM
適用電線範囲 WIRE RANGE AWG#22-#28	TITLE 名称 .062 DIA. CRIMP MALE TERMINAL
被覆外径 INS. RANGE φ 1.1~1.5	DWG. NO. SD-1854*
DRAWN BY '93/07/09 H.HASEGAWA	CHK'D BY '93/07/09 H.HIRAMOTO
APP'D BY '93/07/09 M.FUKUSHIMA	尺度 SCALE 5 : 1
記号 LTR	変更内容 REVISION RECORD
DR. CHK.	日付 DATE
角度 ANGLE	±3°
30 以上 OVER	±0.3
10 以上 30 未満 OVER 30 UNDER	±0.25
10 未満 UNDER	±0.2
一般公差 GENERAL TOLERANCES	