

HYBRID-HIGH RELIABILITY DC/DC CONVERTER

Description

The AFL Series of DC/DC converters feature high power density with no derating over the full military temperature range. This series is offered as part of a complete family of converters providing single and dual output voltages and operating from nominal +28V or +270V inputs with output power ranging from 80W to 120W. For applications requiring higher output power, individual converters can be operated in parallel. The internal current sharing circuits assure equal current distribution among the paralleled converters. This series incorporates International Rectifier's proprietary magnetic pulse feedback technology providing optimum dynamic line and load regulation response. This feedback system samples the output voltage at the pulse width modulator fixed clock frequency, nominally 550KHz. Multiple converters can be synchronized to a system clock in the 500KHz to 700KHz range or to the synchronization output of one converter. Undervoltage lockout, primary and secondary referenced inhibit, soft-start and load fault protection are provided on all models.

These converters are hermetically packaged in two enclosure variations, utilizing copper core pins to minimize resistive DC losses. Three lead styles are available, each fabricated with International Rectifier's rugged ceramic lead-to-package seal assuring long term hermeticity in the most harsh environments.

Manufactured in a facility fully qualified to MIL-PRF-38534, these converters are fabricated utilizing DSCC qualified processes. For available screening options, refer to device screening table in the data sheet. Variations in electrical, mechanical and screening can be accommodated. Contact IR Santa Clara for special requirements.

AFL28XXD SERIES

28V Input, Dual Output

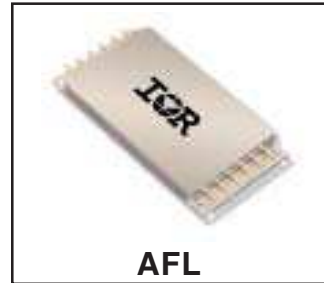

Features

- 16V To 40V Input Range
- $\pm 5V$, $\pm 12V$, and $\pm 15V$ Outputs Available
- High Power Density - up to $70W/in^3$
- Up To 100W Output Power
- Parallel Operation with Power Sharing
- Low Profile (0.380") Seam Welded Package
- Ceramic Feedthru Copper Core Pins
- High Efficiency - to 87%
- Full Military Temperature Range
- Continuous Short Circuit and Overload Protection
- Output Voltage Trim
- Primary and Secondary Referenced Inhibit Functions
- Line Rejection > 40dB - DC to 50KHz
- External Synchronization Port
- Fault Tolerant Design
- Single Output Versions Available
- Standard Microcircuit Drawings Available

Specifications

Absolute Maximum Ratings	
Input voltage	-0.5V to +50VDC
Soldering temperature	300°C for 10 seconds
Operating case temperature	-55°C to +125°C
Storage case temperature	-65°C to +135°C

Static Characteristics $-55^{\circ}\text{C} \leq T_{\text{CASE}} \leq +125^{\circ}\text{C}$, $16\text{V} \leq V_{\text{IN}} \leq 40\text{V}$ unless otherwise specified.

Parameter	Group A Subgroups	Test Conditions	Min	Nom	Max	Unit	
INPUT VOLTAGE		Note 6	16	28	40	V	
OUTPUT VOLTAGE		$V_{\text{IN}} = 28$ Volts, 100% Load					
AFL2805D	1	Positive Output	4.95	5.00	5.05	V	
	1	Negative Output	-5.05	-5.00	-4.95		
AFL2812D	1	Positive Output	11.88	12.00	12.12		
	1	Negative Output	-12.12	-12.00	-11.88		
AFL2815D	1	Positive Output	14.85	15.00	15.15		
	1	Negative Output	-15.15	-15.00	-14.85		
AFL2805D	2, 3	Positive Output	4.90		5.10		
	2, 3	Negative Output	-5.10		-4.90		
AFL2812D	2, 3	Positive Output	11.76		12.24		
	2, 3	Negative Output	-12.24		-11.76		
AFL2815D	2, 3	Positive Output	14.70		15.30		
	2, 3	Negative Output	-15.30		-14.70		
OUTPUT CURRENT		$V_{\text{IN}} = 16, 28, 40$ Volts - Notes 6, 11					
AFL2805D		Either Output			12.8		A
AFL2812D		Either Output			6.4		
AFL2815D		Either Output			5.3		
OUTPUT POWER		Total of Both Outputs. Notes 6, 11					
AFL2805D			80			W	
AFL2812D			96				
AFL2815D			100				
MAXIMUM CAPACITIVE LOAD		Each Output Note 1	10,000			μF	
OUTPUT VOLTAGE TEMPERATURE COEFFICIENT		$V_{\text{IN}} = 28$ Volts, 100% Load - Notes 1, 6	-0.015		+0.015	%/°C	
OUTPUT VOLTAGE REGULATION		Note 10					
Line	1, 2, 3	No Load, 50% Load, 100% Load	-0.5		+0.5	%	
Load	1, 2, 3	$V_{\text{IN}} = 16, 28, 40$ Volts.	-1.0		+1.0		
Cross		$V_{\text{IN}} = 16, 28, 40$ Volts. Note 12					
AFL2805D	1, 2, 3	Positive Output	-1.0		+1.0		
		Negative Output	-8.0		+8.0		
AFL2812D	1, 2, 3	Positive Output	-1.0		+1.0		
		Negative Output	-5.0		+5.0		
AFL2815D	1, 2, 3	Positive Output	-1.0		+1.0		
		Negative Output	-5.0		+5.0		

For Notes to Specifications, refer to page 4

Static Characteristics (Continued)

Parameter	Group A Subgroups	Test Conditions	Min	Nom	Max	Unit
OUTPUT RIPPLE VOLTAGE AFL2805D AFL2812D AFL2815D	1, 2, 3 1, 2, 3 1, 2, 3	V _{IN} = 16, 28, 40 Volts, 100% Load, BW = 10MHz			60 80 80	mV _{pp}
INPUT CURRENT No Load Inhibit 1 Inhibit 2 AFL2805D AFL2812D, 15D	1 2, 3 1, 2, 3 1, 2, 3 1, 2, 3	V _{IN} = 28 Volts I _{OUT} = 0 Pin 4 Shorted to Pin 2 Pin 12 Shorted to Pin 8			80 100 5.0 50 30	mA
INPUT RIPPLE CURRENT AFL2805D AFL2812D AFL2815D	1, 2, 3 1, 2, 3 1, 2, 3	V _{IN} = 28 Volts, 100% Load			60 60 60	mApp
CURRENT LIMIT POINT Expressed as a percentage of Full Rated Load	1 2 3	V _{OUT} = 90% V _{NOM} , Equal current on positive and negative outputs. Note 5	115 105 125		125 115 140	%
LOAD FAULT POWER DISSIPATION Overload or Short Circuit	1, 2, 3	V _{IN} = 28 Volts			33	W
EFFICIENCY AFL2805D AFL2812D AFL2815D	1, 2, 3 1, 2, 3 1, 2, 3	V _{IN} = 28 Volts, 100% Load	78 82 81	81 84 85		%
ENABLE INPUTS (Inhibit Function) Converter Off Sink Current Converter On Sink Current	1, 2, 3 1, 2, 3	Logical Low on Pin 4 or Pin 12 Note 1 Logical High on Pin 4 and Pin 12 - Note 9 Note 1	-0.5 2.0		0.8 100 50 100	V μA V μA
SWITCHING FREQUENCY	1, 2, 3		500	550	600	KHz
SYNCHRONIZATION INPUT Frequency Range Pulse Amplitude, Hi Pulse Amplitude, Lo Pulse Rise Time Pulse Duty Cycle	1, 2, 3 1, 2, 3 1, 2, 3	Note 1 Note 1	500 2.0 -0.5 20		700 10 0.8 100 80	KHz V V ns %
ISOLATION	1	Input to Output or Any Pin to Case (except Pin 3). Test @ 500VDC	100			MΩ
DEVICE WEIGHT		Slight Variations with Case Style		85		g
MTBF		MIL-HDBK-217F, AIF @ T _C = 70°C	300			KHrs

For Notes to Specifications, refer to page 4

Dynamic Characteristics $-55^{\circ}\text{C} \leq T_{\text{CASE}} \leq +125^{\circ}\text{C}$, $V_{\text{IN}}=28\text{V}$ unless otherwise specified.

Parameter	Group A Subgroups	Test Conditions	Min	Nom	Max	Unit
LOAD TRANSIENT RESPONSE						
		Note 2, 8				
AFL2805D	Amplitude	4, 5, 6	-450		450	mV
Either Output	Recovery	4, 5, 6				
		Load Step 50% \Leftrightarrow 100%			200	μs
		Load Step 10% \Leftrightarrow 50%	-450		450	mV
		10% \Rightarrow 50%				
		50% \Rightarrow 10%				
AFL2812D	Amplitude	4, 5, 6	-750		750	mV
Either Output	Recovery	4, 5, 6				
		Load Step 50% \Leftrightarrow 100%			200	μs
		Load Step 10% \Leftrightarrow 50%	-750		750	mV
		10% \Rightarrow 50%				
		50% \Rightarrow 10%				
AFL2815D	Amplitude	4, 5, 6	-750		750	mV
Either Output	Recovery	4, 5, 6				
		Load Step 50% \Leftrightarrow 100%			200	μs
		Load Step 10% \Leftrightarrow 50%	-750		750	mV
		10% \Rightarrow 50%				
		50% \Rightarrow 10%				
		50% \Rightarrow 10%			200	μs
		50% \Rightarrow 10%			400	μs
LINE TRANSIENT RESPONSE						
		Note 1, 2, 3	-500		500	mV
		V_{IN} Step = 16 \Leftrightarrow 40 Volts				
					500	μs
TURN-ON CHARACTERISTICS						
		$V_{\text{IN}} = 16, 28, 40$ Volts. Note 4	0	4.0	250	mV
		Enable 1, 2 on. (Pins 4, 12 high or open)				
					10	ms
LOAD FAULT RECOVERY						
		Same as Turn On Characteristics.				
LINE REJECTION						
		MIL-STD-461D, CS101, 30Hz to 50KHz	40	50		dB
		Note 1				

Notes to Specifications:

- Parameters not 100% tested but are guaranteed to the limits specified in the table.
- Recovery time is measured from the initiation of the transient to where V_{out} has returned to within $\pm 1.0\%$ of V_{out} at 50% load.
- Line transient transition time $\geq 100\mu\text{s}$.
- Turn-on delay is measured with an input voltage rise time of between 100V and 500V per millisecond.
- Current limit point is that condition of excess load causing output voltage to drop to 90% of nominal.
- Parameter verified as part of another test.
- All electrical tests are performed with the remote sense leads connected to the output leads at the load.
- Load transient transition time $\geq 10\mu\text{s}$.
- Enable inputs internally pulled high. Nominal open circuit voltage $\approx 4.0\text{VDC}$.
- Load current split equally between $+V_{\text{out}}$ and $-V_{\text{out}}$.
- Output load must be distributed so that a minimum of 20% of the total output power is being provided by one of the outputs.
- Cross regulation measured with load on tested output at 20% of maximum load while changing the load on other output from 20% to 80%.

Block Diagram
Figure I. Dual Output

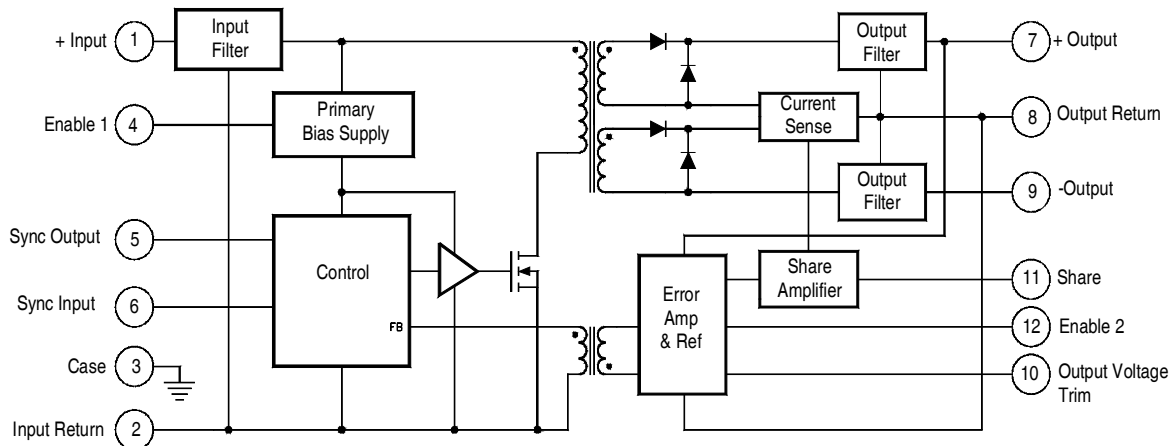

Circuit Operation and Application Information

The AFL series of converters employ a forward switched mode converter topology. (refer to the block diagram in Figure I.) Operation of the device is initiated when a DC voltage whose magnitude is within the specified input voltage limits is applied between pins 1 and 2. If pin 4 is enabled (at a logical 1 or open) the primary bias supply will begin generating a regulated housekeeping voltage bringing the circuitry on the primary side of the converter to life. A power MOSFET is used to chop the DC input voltage into a high frequency square wave, applying this chopped voltage to the power transformer at the nominal converter switching frequency. By maintaining a DC voltage within specified operating range at the input, continuous generation of the bias voltage is assured.

The switched voltage impressed on the secondary output transformer windings is rectified and filtered to provide the positive and negative converter output voltages. An error amplifier on the secondary side compares the positive output voltage to a precision reference and generates an error signal proportional to the difference. This error signal is magnetically coupled through the feedback transformer into the control section of the converter varying the pulse width of the square wave signal driving the MOSFETs, narrowing the pulse width if the output voltage is too high and widening it if it is too low. These pulse width variations provide the necessary corrections to regulate the magnitude of output voltage within its' specified limits.

Because the primary portion of the circuit is coupled to the secondary side with magnetic elements, full isolation from input to output is maintained.

Although incorporating several sophisticated and useful ancillary features, basic operation of the AFL28XXD series

series can be initiated by simply applying an input voltage to pins 1 and 2 and connecting the appropriate loads between pins 7, 8, and 9. As is the case with any high power density converter, operation should not be initiated before secure attachment to an appropriate heat dissipator. (See **Thermal Considerations**, page 7) Additional application information is provided in the paragraphs following.

Inhibiting Converter Output (Enable)

As an alternative to application and removal of the DC voltage to the input, the user can control the converter output by providing TTL compatible, positive logic signals to either of two enable pins (pin 4 or 12). The distinction between these two signal ports is that enable 1 (pin 4) is referenced to the input return (pin 2) while enable 2 (pin 12) is referenced to the output return (pin 8). Thus, the user has access to an inhibit function on either side of the isolation barrier. Each port is internally pulled "high" so that when not used, an open connection on both enable pins permits normal converter operation. When their use is desired, a logical "low" on either port will shut the converter down.

Figure II. Enable Input Equivalent Circuit

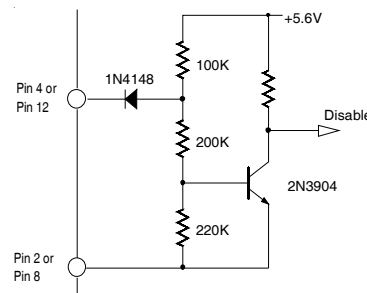

AFL28XXD Series

Internally, these ports differ slightly in their function. In use, a low on Enable 1 completely shuts down all circuits in the converter, while a low on Enable 2 shuts down the secondary side while altering the controller duty cycle to near zero. Externally, the use of either port is transparent to the user save for minor differences in idle current. (See specification table).

Synchronization of Multiple Converters

When operating multiple converters, system requirements often dictate operation of the converters at a common frequency. To accommodate this requirement, the AFL series converters provide both a synchronization input and output.

The sync input port permits synchronization of an AFL converter to any compatible external frequency source operating between 500KHz and 700KHz. This input signal should be referenced to the input return and have a 10% to 90% duty cycle. Compatibility requires transition times less

than 100ns, maximum low level of +0.8V and a minimum high level of +2.0V. The sync output of another converter which has been designated as the master oscillator provides a convenient frequency source for this mode of operation. When external synchronization is not indicated, the sync in pin should be left open (unconnected) thereby permitting the converter to operate at its' own internally set frequency.

The sync output signal is a continuous pulse train set at $550 \pm 50\text{KHz}$, with a duty cycle of $15 \pm 5\%$. This signal is referenced to the input return and has been tailored to be compatible with the AFL sync input port. Transition times are less than 100ns and the low level output impedance is less than 50Ω . This signal is active when the DC input voltage is within the specified operating range and the converter is not inhibited. This synch output has adequate drive reserve to synchronize at least five additional converters. A typical synchronization connection option is illustrated in Figure III.

Figure III. Preferred Connection for Parallel Operation

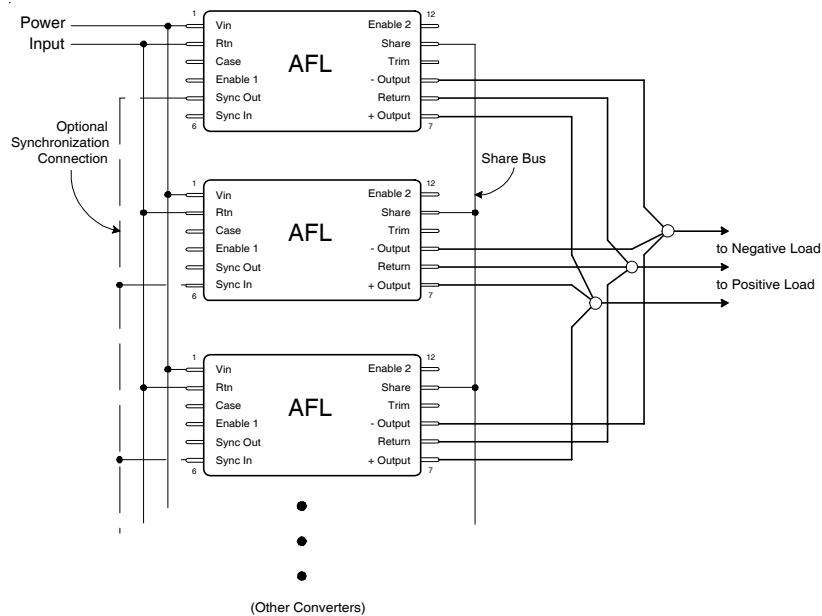

Parallel Operation-Current and Stress Sharing

Figure III. illustrates the preferred connection scheme for operation of a set of AFL converters with outputs operating in parallel. Use of this connection permits equal current sharing among the members of a set whose load current exceeds the capacity of an individual AFL. An important

feature of the AFL series operating in the parallel mode is that in addition to sharing the current, the stress induced by temperature will also be shared. Thus if one member of a paralleled set is operating at a higher case temperature, the current it provides to the load will be reduced as compensation for the temperature induced stress on that device.

When operating in the shared mode, it is important that symmetry of connection be maintained as an assurance of optimum load sharing performance. Thus, converter outputs should be connected to the load with equal lengths of wire of the same gauge and should be connected to a common physical point, preferably at the load along with the converter output and return leads. All converters in a paralleled set must have their share pins connected together. This arrangement is diagrammatically illustrated in Figure III, showing the output and return pins connected at a star point which is located close as possible to the load.

As a consequence of the topology utilized in the current sharing circuit, the share pin may be used for other functions. In applications requiring only a single converter, the voltage appearing on the share pin may be used as a "total current monitor". The share pin open circuit voltage is nominally +1.00V at no load and increases linearly with increasing total output current to +2.20V at full load. Note that the current we refer to here is the total output current, that is, the sum of the positive and negative output currents.

Thermal Considerations

Because of the incorporation of many innovative technological concepts, the AFL series of converters is capable of providing very high output power from a package of very small volume. These magnitudes of power density can only be obtained by combining high circuit efficiency with effective methods of heat removal from the die junctions. This requirement has been effectively addressed inside the device; but when operating at maximum loads, a significant amount of heat will be generated and this heat must be conducted away from the case. To maintain the case temperature at or below the specified maximum of 125°C, this heat must be transferred by conduction to an appropriate heat dissipater held in intimate contact with the converter base-plate.

Since the effectiveness of this heat transfer is dependent on the intimacy of the baseplate/heatsink interface, it is strongly recommended that a high thermal conductivity heat transferring medium is inserted between the baseplate and heatsink. The material most frequently utilized at the factory during all testing and burn-in processes is sold under the trade name of Sil-Pad® 400¹. This particular product is an insulator but electrically conductive versions are also available. Use of these materials assures maximum surface contact with the heat dissipater thereby compensating for any minor surface variations. While other available types of heat conductive materials and thermal compounds provide similar effectiveness, these alternatives are often less convenient and can be somewhat messy to use.

¹Sil-Pad is a registered Trade Mark of Bergquist, Minneapolis, MN

A conservative aid to estimating the total heat sink surface area ($A_{\text{HEAT SINK}}$) required to set the maximum case temperature rise (ΔT) above ambient temperature is given by the following expression:

$$A_{\text{HEAT SINK}} \approx \left\{ \frac{\Delta T}{80P^{0.85}} \right\}^{-1.43} - 3.0$$

where

ΔT = Case temperature rise above ambient

$$P = \text{Device dissipation in Watts} = P_{\text{OUT}} \left\{ \frac{1}{\text{Eff}} - 1 \right\}$$

As an example, assume that it is desired to operate an AFL2815D in a still air environment where the ambient temperature is held to a constant +25°C while holding the case temperature at $T_c \leq +85^\circ\text{C}$; then case temperature rise is

$$\Delta T = 85 - 25 = 60^\circ\text{C}$$

From the Specification Table, the worst case full load efficiency for AFL2815D is 83% at 100W: thus, power dissipation at full load is given by

$$P = 100 \cdot \left\{ \frac{1}{.83} - 1 \right\} = 100 \cdot (0.205) = 20.5\text{W}$$

and the required heat sink area is

$$A_{\text{HEAT SINK}} = \left\{ \frac{60}{80 \cdot 20.5^{0.85}} \right\}^{-1.43} - 3.0 = 56.3 \text{ in}^2$$

Thus, a total heat sink surface area (including fins, if any) of 56 in² in this example, would limit case rise to 60°C above ambient. A flat aluminum plate, 0.25" thick and of approximate dimension 4" by 7" (28 in² per side) would suffice for this application in a still air environment. Note that to meet the criteria in this example, both sides of the plate require unrestricted exposure to the +25°C ambient air.

Input Filter

The AFL28XXD series converters incorporate a two stage LC input filter whose elements dominate the input load impedance characteristic during the turn-on sequence. The input circuit is as shown in Figure IV.

Figure IV. Input Filter Circuit

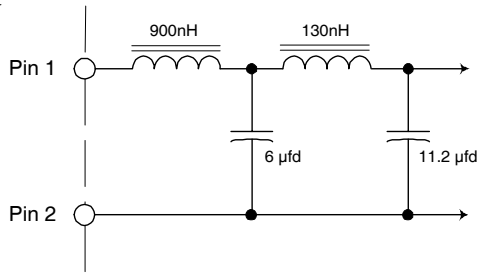

Undervoltage Lockout

A minimum voltage is required at the input of the converter to initiate operation. This voltage is set to $14V \pm 0.5V$. To preclude the possibility of noise or other variations at the input falsely initiating and halting converter operation, a hysteresis of approximately 1.0V is incorporated in this circuit. Thus if the input voltage droops to $13V \pm 0.5V$, the converter will shut down and remain inoperative until the input voltage returns to $\approx 14V$.

Output Voltage Adjust

By use of the trim pin (10), the magnitude of output voltages can be adjusted over a limited range in either a positive or negative direction. Connecting a resistor between the trim pin and either the output return or the positive output will raise or lower the magnitude of output voltages. The span of output voltage adjustment is restricted to the limits shown in Table I.

Figure V. Connection for V_{OUT} Adjustment

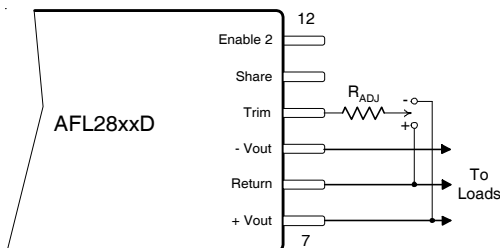

Connect R_{adj} to + to increase, - to decrease

Table 1. Output Voltage Trim Values and Limits

AFL2805D		AFL2812D		AFL2815D	
V_{out}	R_{adj}	V_{out}	R_{adj}	V_{out}	R_{adj}
5.5	0	12.5	0	15.5	0
5.4	12.5K	12.4	47.5K	15.4	62.5K
5.3	33.3K	12.3	127K	15.3	167K
5.2	75K	12.2	285K	15.2	375K
5.1	200K	12.1	760K	15.1	1.0M
5.0	∞	12.0	∞	15.0	∞
4.9	190K	11.7	975K	14.6	1.2M
4.8	65K	11.3	288K	14.0	325K
4.7	23K	10.8	72.9K	13.5	117K
4.6	2.5K	10.6	29.9K	13.0	12.5K
4.583	0	10.417	0	12.917	0

Note that the nominal magnitude of output voltage resides in the middle of the table and the corresponding resistor value is set to ∞ . To set the magnitude greater than nominal, the adjust resistor is connected to output return. To set the magnitude less than nominal, the adjust resistor is connected to the positive output. (Refer to Figure V.)

For output voltage settings that are within the limits, but between those listed in Table I, it is suggested that the resistor values be determined empirically by selection or by use of a variable resistor. The value thus determined can then be replaced with a good quality fixed resistor for permanent installation.

When use of this adjust feature is elected, the user should be aware that the temperature performance of the converter output voltage will be affected by the temperature performance of the resistor selected as the adjustment element and therefore, is advised to employ resistors with a tight temperature coefficient of resistance.

General Application Information

The AFL28XXD series of converters are capable of providing large transient currents to user loads on demand. Because the nominal input voltage range in this series is relatively low, the resulting input current demands will be correspondingly large. It is important therefore, that the line impedance be kept very low to prevent steady state and transient input currents from degrading the supply voltage between the voltage source and the converter input. In applications requiring high static currents and large transients, it is recommended that the input leads be made of adequate size to minimize resistive losses, and that a good quality capacitor of approximately $100\mu fd$ be connected directly across the input terminals to assure an adequately low impedance at the input terminals. Table I relates nominal resistance values and selected wire sizes.

Table 2. Nominal Resistance of Cu Wire

Wire Size, AWG	Resistance per ft
24 Ga	25.7 mΩ
22 Ga	16.2 mΩ
20 Ga	10.1 mΩ
18 Ga	6.4 mΩ
16 Ga	4.0 mΩ
14 Ga	2.5 mΩ
12 Ga	1.6 mΩ

As an example of the effects of parasitic resistance, consider an AFL2815D operating at full power of 100W. From the specification sheet, this device has a minimum efficiency of 83% which represents an input power of more than 120W. If we consider the case where line voltage is at its' minimum of 16V, the steady state input current necessary for this example will be slightly greater than 7.5A. If this device were connected to a voltage source with 10 feet of 20 gauge wire, the round trip (input and return) would result in 0.2Ω of resistance and 1.5V of drop from the source to the converter. To assure 16V at the input, a source closer to 18V would be required. In applications using the paralleling option, this drop will be multiplied by the number of paralleled devices. By choosing 14 or 16 gauge wire in this example, the parasitic resistance and resulting voltage drop will be reduced to 25% or 31% of that with 20 gauge wire.

Another potential problem resulting from parasitically induced voltage drop on the input lines is with regard to the operation of the enable 1 port. The minimum and maximum operating levels required to operate this port are specified with respect to the input common return line at the converter. If a logic signal is generated with respect to a 'common' that is distant from the converter, the effects of the voltage drop over the return line must be considered when establishing the worst case TTL switching levels. These drops will effectively impart a shift to the logic levels. In Figure VI, it can be seen that referred to system ground, the voltage on the input return pin is given by

$$e_{Rtn} = I_{Rtn} \cdot R_p$$

Therefore, the logic signal level generated in the system must be capable of a TTL logic high plus sufficient additional amplitude to overcome e_{Rtn} . When the converter is inhibited, I_{Rtn} diminishes to near zero and e_{Rtn} will then be at system ground.

Incorporation of a 100μfd capacitor at the input terminals is recommended as compensation for the dynamic effects of the parasitic resistance of the input cable reacting with the complex impedance of the converter input, and to provide an energy reservoir for transient input current requirements.

Figure VI. Problems of Parasitic Resistance in input Leads

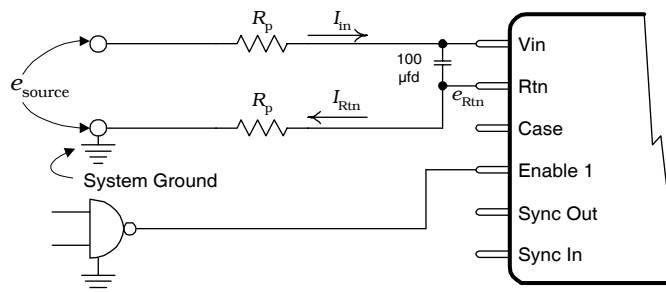

Mechanical Outlines

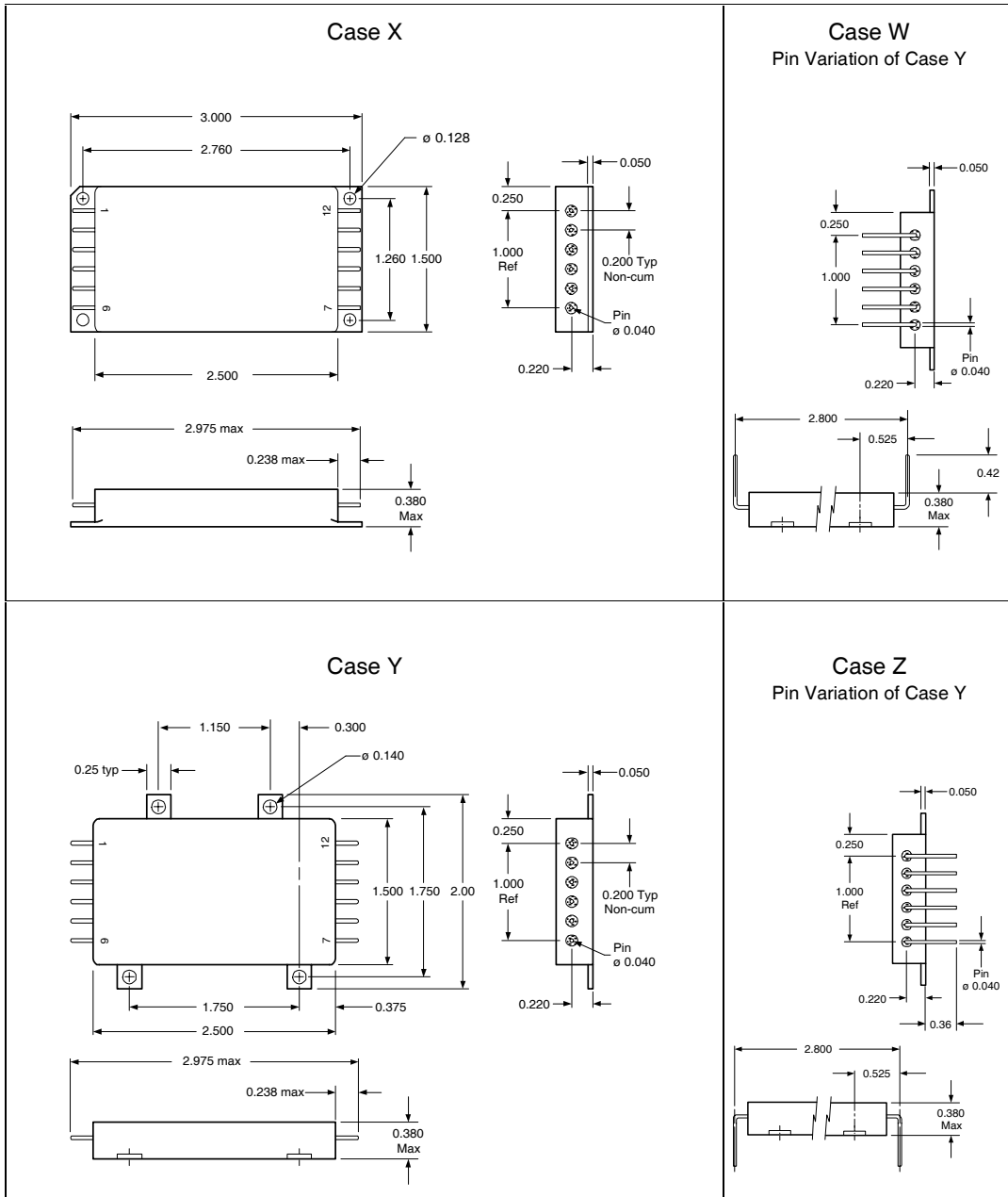

Tolerances, unless otherwise specified: .XX = ± 0.010

.XXX = ± 0.005

BERYLLIA WARNING: These converters are hermetically sealed; however they contain BeO substrates and should not be ground or subjected to any other operations including exposure to acids, which may produce Beryllium dust or fumes containing Beryllium

Pin Designation

Pin #	Designation
1	+ Input
2	Input Return
3	Case Ground
4	Enable 1
5	Sync Output
6	Sync Input
7	+ Output
8	Output Return
9	- Output
10	Output Voltage Trim
11	Share
12	Enable 2

Standard Microcircuit Drawing Equivalence Table

Standard Microcircuit Drawing Number	IR Standard Part Number
5962-95795	AFL2805D
5962-95796	AFL2812D
5962-94724	AFL2815D

Device Screening

Requirement	MIL-STD-883 Method	No Suffix	ES ②	HB	CH
Temperature Range	—	-20°C to +85°C	-55°C to +125°C ③	-55°C to +125°C	-55°C to +125°C
Element Evaluation	MIL-PRF-38534	N/A	N/A	N/A	Class H
Non-Destructive Bond Pull	2023	N/A	N/A	N/A	N/A
Internal Visual	2017	①	Yes	Yes	Yes
Temperature Cycle	1010	N/A	Cond B	Cond C	Cond C
Constant Acceleration	2001, Y1 Axis	N/A	500 Gs	3000 Gs	3000 Gs
PIND	2020	N/A	N/A	N/A	N/A
Burn-In	1015	N/A	48 hrs@hi temp	160 hrs@125°C	160 hrs@125°C
Final Electrical (Group A)	MIL-PRF-38534 & Specification	25°C	25°C ②	-55°C, +25°C, +125°C	-55°C, +25°C, +125°C
PDA	MIL-PRF-38534	N/A	N/A	N/A	10%
Seal, Fine and Gross	1014	Cond A	Cond A, C	Cond A, C	Cond A, C
Radiographic	2012	N/A	N/A	N/A	N/A
External Visual	2009	①	Yes	Yes	Yes

Notes:

- ① Best commercial practice
- ② Sample tests at low and high temperatures
- ③ -55°C to +105°C for AHE, ATO, ATW

