

AHE28XXD SERIES

28V Input, Dual Output

HYBRID-HIGH RELIABILITY DC/DC CONVERTER

Description

The AHE Series of DC/DC converters feature high power density and an extended temperature range for use in military and industrial applications. Designed to MIL-STD-704D input requirements, these devices have nominal 28VDC inputs with $\pm 5V$, $\pm 12V$ and $\pm 15V$ dual outputs to satisfy a wide range of requirements. The circuit design incorporates a pulse width modulated push-pull topology operating in the feed-forward mode at a nominal switching frequency of 250KHz. Input to output isolation is achieved through the use of transformers in the forward and feedback circuits.

The advanced feedback design provides fast loop response for superior line and load transient characteristics and offers greater reliability and radiation tolerance than devices incorporating optical feedback circuits.

Manufactured in a facility fully qualified to MIL-PRF-38534, these converters are fabricated utilizing DSCC qualified processes. For available screening options, refer to device screening table in the data sheet. Variations in electrical, mechanical and screening can be accommodated. Contact IR Santa Clara for special requirements.



Features

- 17V to 40VDC Input Range
- 28VDC Nominal Input
- $\pm 5V$, $\pm 12V$ and $\pm 15V$ Outputs Available
- Indefinite Short Circuit and Overload Protection
- $12.9W/in^3$ Power Density
- 15W Output Power
- Fast Loop Response for Superior Transient Characteristics
- Operating Temperature Range from $-55^\circ C$ to $+125^\circ C$ Available
- Popular Industry Standard Pin-Out
- Resistance Seam Welded Case for Superior Long Term Hermeticity
- Efficiencies up to 82%
- Shutdown from External Signal
- Military Screening
- 314,000 hour MTBF at $85^\circ C$ (AUC)
- Standard Microcircuit Drawings Available

Specifications

AHE2805D

| Absolute Maximum Ratings | |
|----------------------------|----------------------|
| Input voltage | -0.5V to +50VDC |
| Soldering temperature | 300°C for 10 seconds |
| Operating case temperature | -55°C to +125°C |
| Storage case temperature | -65°C to +135°C |

Table I. Electrical Performance Characteristics

| Test | Symbol | Conditions -55°C ≤ Tc ≤ +125°C Vin = 28 Vdc ±5%, CL = 0 Unless otherwise specified | Group A Subgroups | Device Types | Limits | | Unit |
|--|---------------------|---|----------------------|-----------------|--------|-------|-------------------|
| | | | | | Min | Max | |
| Output voltage | V _{OUT} | I _{OUT} = 0 | 1 | All | ±4.95 | ±5.05 | V |
| | | | 2,3 | | ±4.90 | ±5.10 | |
| Output current ^{9,11} | I _{OUT} | V _{IN} = 17, 28, and 40 V dc | 1,2,3 | All | 0.0 | ±625 | mA |
| Output ripple voltage ^{8,9} | V _{RIP} | V _{IN} = 17, 28, and 40 V dc, B.W. = DC to 2MHz | 1,2,3 | All | | 60 | mVp-p |
| Output power ^{4,9,11} | P _{OUT} | V _{IN} = 17,28, and 40 V dc | 1,2,3 | All | 15 | | W |
| Line ⁹ Regulation ¹⁰ | VR _{LINE} | V _{IN} = 17, 28, and 40 V dc, I _{OUT} = 0, ±313, and ±625mA | 1 | All | | 25 | mV |
| | | | 2,3 | | | 50 | |
| Load Regulation ⁹ | VR _{LOAD} | V _{IN} = 17, 28, and 40 V dc, I _{OUT} = 0, ±313, and ±625 mA | 1,2,3 | All | | 110 | mV |
| Input current | I _{IN} | I _{OUT} = 0, inhibit (pin 2) tied to input return (pin 10) | 1,2,3 | All | | 18 | mA |
| | | I _{OUT} = 0, inhibit (pin 2) = open | | | | 40 | |
| Input ripple current ⁸ | I _{RIP} | I _{OUT} = ±625mA B.W. = DC to 2MHz | 1,2,3 | All | | 50 | mA _{p-p} |
| Efficiency | E _{FF} | I _{OUT} = ±625mA T _C = +25°C | 1 | All | 80 | | % |
| Isolation | ISO | Input to output or any pin to case (except pin 8) at 500V dc Tc = +25°C | 1 | All | 100 | | MΩ |
| Capacitive load ^{6,12} | C _L | No effect on dc performance, Tc = +25°C | 4 | All | | 200 | μF |
| Power dissipation load fault | P _D | Overload, T _C = +25°C ³ | 1 | All | | 6.0 | W |
| | | Short circuit, T _C = +25°C | 1 | | | 6.0 | |
| Switching frequency ⁹ | F _S | I _{OUT} = ±625mA | 4,5,6 | 01 | 225 | 275 | KHz |
| | | | | 02 | 225 | 245 | |
| | | | | 03 | 250 | 275 | |
| Output response to step transient load changes ⁷ | VO _{TLOAD} | 50% load to/from 100% load | 4 | All | -300 | +300 | mVpk |
| | | | 5,6 | | -450 | +450 | |
| | | No load to/from 50% load | 4 | All | -500 | +500 | |
| | | | 5,6 | | -750 | +750 | |

For Notes to Specifications, refer to page 3

Table I. Electrical Performance Characteristics - continued

AHE2805D

| Test | Symbol | Conditions -55° ≤ Tc ≤ +125°C Vin = 28 Vdc ±5%, CL= 0 unless otherwise specified | Group A Subgroups | Device Types | Limits | | Unit |
|---|---------------------|--|----------------------|-----------------|--------|-------|------|
| | | | | | Min | Max | |
| Recovery time step transient load changes ^{1,7} | TT _{LOAD} | 50% load to/from 100% load | 4 | All | | 70 | μs |
| | | | 5,6 | | 100 | | |
| | | No load to 50% load | 4,5,6 | All | 1500 | ms | |
| | | 50% load to no load | 4,5,6 | All | 5.0 | | |
| Output response transient step line changes ^{5,12} | VO _{TLINE} | Input step 17 to 40V dc | 4,5,6 | All | | 1200 | mVpk |
| | | Input step 40 to 17V dc | 4,5,6 | All | | -1500 | |
| Recovery time transient step line changes ^{1,5,12} | TT _{LINE} | Input step 17 to 40V dc | 4,5,6 | All | | 4.0 | ms |
| | | Input step 40 to 17V dc | 4,5,6 | All | | 4.0 | |
| Turn on overshoot ⁹ | V _{TonOS} | I _{OUT} = 0 and ±625mA | 4,5,6 | All | | 600 | mVpk |
| Turn on delay ^{2,9} | T _{onD} | I _{OUT} = 0 and ±625mA | 4,5,6 | All | | 10 | ms |
| Load fault recovery ¹² | T _{rLF} | | 4,5,6 | All | | 10 | ms |

Notes to Specifications

- 1 Recovery time is measured from the initiation of the transient to where V_{OUT} has returned to within ±0.1 % of V_{OUT} at 50 % load.
- 2 Turn on delay time measurement is for either a step application of power at the input or the removal of a ground signal from the inhibit pin (pin 2) while power is applied to the input.
- 3 An overload is that condition with a load in excess of the rated load but less than that necessary to trigger the short circuit protection and is the condition of maximum power dissipation.
- 4 Total power at both outputs. For operation at 16V dc input, derate output power by 33 %.
- 5 Input step transition time between 2.0μs and 10μs.
- 6 Capacitive load may be any value from 0 to the maximum limit without compromising dc performance. A capacitive load in excess of the maximum limit will not disturb loop stability but may interfere with the operation of the load fault detection circuitry, appearing as a short circuit during turn-on.
- 7 Load step transition time between 2.0μs and 10μs.
- 8 Bandwidth guaranteed by design. Tested for 20KHz to 2.0MHz.
- 9 Tested at each output.
- 10 When operating with unbalanced loads, at least 25 % of the load must be on the positive output to maintain regulation.
- 11 Parameter guaranteed by line and load regulation tests.
- 12 Parameter shall be tested as part of design characterization and after design or process changes. Thereafter parameters shall be guaranteed to the limits specified in Table I.

Specifications

AHE2812D

| Absolute Maximum Ratings | |
|----------------------------|----------------------|
| Input voltage | -0.5V to +50VDC |
| Soldering temperature | 300°C for 10 seconds |
| Operating case temperature | -55°C to +125°C |
| Storage case temperature | -65°C to +135°C |

Table II. Electrical Performance Characteristics

| Test | Symbol | Conditions -55°C ≤ T _C ≤ +125°C V _{IN} = 28 Vdc ±5%, C _L = 0 Unless otherwise specified | Group A Subgroups | Device Types | Limits | | Unit |
|--|---------------------|---|----------------------|-----------------|--------|--------|--------|
| | | | | | Min | Max | |
| Output voltage | V _{OUT} | I _{OUT} = 0 | 1 | All | ±11.88 | ±12.12 | V |
| | | | 2,3 | | ±11.70 | ±12.24 | |
| Output current ^{9,11} | I _{OUT} | V _{IN} = 17, 28, and 40 V dc | 1,2,3 | All | 0.0 | ±625 | mA |
| Output ripple voltage ^{8,9} | V _{RIP} | V _{IN} = 17, 28, and 40 V dc, B.W. = DC to 2MHz | 1,2,3 | All | | 60 | mVp-p |
| Output power ^{4,9,11} | P _{OUT} | V _{IN} = 17,28, and 40 V dc | 1,2,3 | All | 15 | | W |
| Line Regulation ^{9,10} | VR _{LINE} | V _{IN} = 17, 28, and 40 V dc, I _{out} = 0, ±313, and ±625mA | 1 | All | | 30 | mV |
| | | | 2,3 | | 60 | | |
| Load Regulation ⁹ | VR _{LOAD} | V _{IN} = 17, 28, and 40 V dc, I _{OUT} = 0, ±313, and ±625 mA | 1,2,3 | All | | 120 | mV |
| Input current | I _{IN} | I _{OUT} = 0, inhibit (pin 2) tied to input return (pin 10) | 1,2,3 | All | | 18 | mA |
| | | I _{OUT} = 0, inhibit (pin 2) = open | | | 40 | | |
| Input ripple current ⁸ | I _{RIP} | I _{OUT} = ±625mA B.W. = DC to 2MHz | 1,2,3 | All | | 50 | mA-p-p |
| Efficiency | E _{EFF} | I _{OUT} = ±625mA T _C = +25°C | 1 | All | 80 | | % |
| Isolation | ISO | Input to output or any pin to case (except pin 8) at 500V dc T _C = +25°C | 1 | All | 100 | | MΩ |
| Capacitive load ^{6,12} | C _L | No effect on dc performance, T _C = +25°C | 4 | All | | 200 | μF |
| Power dissipation load fault | P _D | Overload, T _C = +25°C ³ | 1 | All | | 6.0 | W |
| | | Short circuit, T _C = +25°C | 1 | | 6.0 | | |
| Switching frequency ⁹ | F _S | I _{OUT} = ±625mA | 4,5,6 | 01 | 225 | 275 | KHz |
| | | | | 02 | 225 | 245 | |
| | | | | 03 | 250 | 275 | |
| Output response to step transient load changes ⁷ | VO _{TLOAD} | 50% load to/from 100% load | 4 | All | -300 | +300 | mVpk |
| | | | 5,6 | | -450 | +450 | |
| | | No load to/from 50% load | 4 | All | -500 | +500 | |
| | | | 5,6 | | -750 | +750 | |

Table II. Electrical Performance Characteristics - continued

AHE2812D

| Test | Symbol | Conditions -55° ≤ Tc ≤ +125°C Vin = 28 Vdc ±5%, CL= 0 unless otherwise specified | Group A Subgroups | Device Types | Limits | | Unit |
|---|---------------------|--|----------------------|-----------------|--------|-------|------|
| | | | | | Min | Max | |
| Recovery time step transient load changes ^{1,7} | TT _{LOAD} | 50% load to/from 100% load | 4 | All | | 70 | μs |
| | | | 5,6 | | | 100 | |
| | | No load to 50% load | 4,5,6 | All | | 1500 | ms |
| | | 50% load to no load | 4,5,6 | All | | 5.0 | |
| Output response transient step line changes ^{5,12} | VO _{TLINE} | Input step 17 to 40V dc | 4,5,6 | All | | 1200 | mVpk |
| | | Input step 40 to 17V dc | 4,5,6 | All | | -1500 | |
| Recovery time transient step line changes ^{1,5,12} | TT _{LINE} | Input step 17 to 40V dc | 4,5,6 | All | | 4.0 | ms |
| | | Input step 40 to 17V dc | 4,5,6 | All | | 4.0 | |
| Turn on overshoot ⁹ | V _{TonOS} | I _{OUT} = 0 and ±625mA | 4,5,6 | All | | 600 | mVpk |
| Turn on delay ^{2,9} | T _{onD} | I _{OUT} = 0 and ±625mA | 4,5,6 | All | | 10 | ms |
| Load fault recovery ¹² | T _{rLF} | | 4,5,6 | All | | 10 | ms |

Notes to Specifications

- 1 Recovery time is measured from the initiation of the transient to where V_{OUT} has returned to within ±0.1% of V_{OUT} at 50 % load.
- 2 Turn on delay time measurement is for either a step application of power at the input or the removal of a ground signal from the inhibit pin (pin 2) while power is applied to the input.
- 3 An overload is that condition with a load in excess of the rated load but less than that necessary to trigger the short circuit protection and is the condition of maximum power dissipation.
- 4 Total power at both outputs. For operation at 16V dc input, derate output power by 33 %.
- 5 Input step transition time between 2.0μs and 10μs.
- 6 Capacitive load may be any value from 0 to the maximum limit without compromising dc performance. A capacitive load in excess of the maximum limit will not disturb loop stability but may interfere with the operation of the load fault detection circuitry, appearing as a short circuit during turn-on.
- 7 Load step transition time between 2.0μs and 10μs.
- 8 Bandwidth guaranteed by design. Tested for 20KHz to 2.0MHz.
- 9 Tested at each output.
- 10 When operating with unbalanced loads, at least 25 % of the load must be on the positive output to maintain regulation.
- 11 Parameter guaranteed by line and load regulation tests.
- 12 Parameter shall be tested as part of design characterization and after design or process changes. Thereafter parameters shall be guaranteed to the limits specified in Table II.

Specifications

AHE2815D

| Absolute Maximum Ratings | |
|----------------------------|----------------------|
| Input voltage | -0.5V to +50VDC |
| Soldering temperature | 300°C for 10 seconds |
| Operating case temperature | -55°C to +125°C |
| Storage case temperature | -65°C to +135°C |

Table III. Electrical Performance Characteristics

| Test | Symbol | Conditions -55°C ≤ T _C ≤ +125°C V _{IN} = 28 Vdc ±5%, C _L = 0 Unless otherwise specified | Group A Subgroups | Device Types | Limits | | Unit |
|---|---------------------|---|----------------------|-----------------|--------|--------|-------------------|
| | | | | | Min | Max | |
| Output voltage | V _{OUT} | I _{OUT} = 0 | 1 | All | ±14.85 | ±15.15 | V |
| | | | 2,3 | | ±14.70 | ±15.30 | |
| Output current ^{9, 11} | I _{OUT} | V _{IN} = 17, 28, and 40 V dc | 1,2,3 | All | 0.0 | ±500 | mA |
| Output ripple voltage ^{8, 9} | V _{RIP} | V _{IN} = 17, 28, and 40 V dc, B.W. = dc to 2 mHz | 1,2,3 | All | | 60 | mVp-p |
| Output power ^{4, 9, 11} | P _{OUT} | V _{IN} = 17, 28, and 40 V dc | 1,2,3 | All | 15 | | W |
| Line Regulation ^{9, 10} | VR _{LINE} | V _{IN} = 17, 28, and 40 V dc, I _{OUT} = 0, ±250, and ±500mA | 1 | All | | 35 | mV |
| | | | 2,3 | | | 75 | |
| Load Regulation ⁹ | VR _{LOAD} | V _{IN} = 17, 28, and 40 V dc, I _{OUT} = 0, ±250, and ±625 mA | 1,2,3 | All | | 150 | mV |
| Input current | I _{IN} | I _{OUT} = 0, inhibit (pin 2) tied to input return (pin 10) | 1,2,3 | All | | 18 | mA |
| | | I _{OUT} = 0, inhibit (pin 2) = open | | | | 40 | |
| Input ripple current ⁸ | I _{RIP} | I _{OUT} = ±500mA B.W. = DC to 2MHz | 1,2,3 | All | | 50 | mA _{p-p} |
| Efficiency | E _{FF} | I _{OUT} = ±500mA T _C = +25°C | 1 | All | 80 | | % |
| Isolation | ISO | Input to output or any pin to case (except pin 8) at 500V dc T _C = +25°C | 1 | All | 100 | | MΩ |
| Capacitive load ^{6, 12} | C _L | No effect on dc performance, T _C = +25°C | 4 | All | | 200 | μF |
| Power dissipation load fault | P _D | Overload, T _C = +25°C ³ | 1 | All | | 6.0 | W |
| Switching frequency ⁹ | F _S | I _{OUT} = ±500mA | 4,5,6 | 01 | 225 | 275 | KHz |
| | | | | 02 | 225 | 245 | |
| | | | | 03 | 250 | 275 | |
| Output response to step transient load changes ⁷ | VO _{TLOAD} | 50% load to/from 100% load | 4 | All | -300 | +300 | mVpk |
| | | | 5,6 | | -450 | +450 | |
| | | No load to/from 50% load | 4 | All | -500 | +500 | |
| | | | 5,6 | | -750 | +750 | |

Refer Notes to Specifications, refer to page 5

Table III. Electrical Performance Characteristics - continued

AHE2815D

| Test | Symbol | Conditions -55°C ≤ T _c ≤ +125°C V _{in} = 28 Vdc ±5%, C _L = 0 unless otherwise specified | Group A Subgroups | Device Types | Limits | | Unit |
|--|---------------------|---|----------------------|-----------------|--------|-------|-------|
| | | | | | Min | Max | |
| Recovery time step transient load changes ^{1, 7} | TT _{LOAD} | 50% load to/from 100% load | 4 | All | | 70 | μs |
| | | | 5,6 | | | 100 | |
| | | No load to 50% load | 4,5,6 | All | | 1500 | ms |
| | | 50% load to no load | 4,5,6 | All | | 5.0 | |
| Output response transient step line changes ^{5, 12} | VO _{TLINE} | Input step 17 to 40V dc | 4,5,6 | All | | 1500 | mV pk |
| | | Input step 40 to 17V dc | 4,5,6 | All | | -1500 | |
| Recovery time transient step line changes ^{1, 5, 12} | TT _{LINE} | Input step 17 to 40V dc | 4,5,6 | All | | 4.0 | ms |
| | | Input step 40 to 17V dc | 4,5,6 | All | | 4.0 | |
| Turn on overshoot ⁹ | VT _{OnOS} | I _{OUT} = 0 and ±500mA | 4,5,6 | All | | 600 | mV pk |
| Turn on delay ^{2,9} | Ton _D | I _{OUT} = 0 and ±500mA | 4,5,6 | All | | 10 | ms |
| Load fault recovery ¹² | Tr _{LF} | | 4,5,6 | All | | 10 | ms |

Notes to Specifications

- 1 Recovery time is measured from the initiation of the transient to where V_{OUT} has returned to within ±0.1 % of V_{OUT} at 50 % load.
- 2 Turn on delay time measurement is for either a step application of power at the input or the removal of a ground signal from the inhibit pin (pin 2) while power is applied to the input.
- 3 An overload is that condition with a load in excess of the rated load but less than that necessary to trigger the short circuit protection and is the condition of maximum power dissipation.
- 4 Total power at both outputs. For operation at 16Vdc input, derate output power by 33 %.
- 5 Input step transition time between 2.0μs and 10μs.
- 6 Capacitive load may be any value from 0 to the maximum limit without compromising dc performance. A capacitive load in excess of the maximum limit will not disturb loop stability but may interfere with the operation of the load fault detection circuitry, appearing as a short circuit during turn-on.
- 7 Load step transition time between 2.0μs and 10μs.
- 8 Bandwidth guaranteed by design. Tested for 20KHz to 2.0MHz.
- 9 Tested at each output.
- 10 When operating with unbalanced loads, at least 25 % of the load must be on the positive output to maintain regulation.
- 11 Parameter guaranteed by line and load regulation tests.
- 12 Parameter shall be tested as part of design characterization and after design or process changes. Thereafter parameters shall be guaranteed to the limits specified in Table III.

Block Diagram

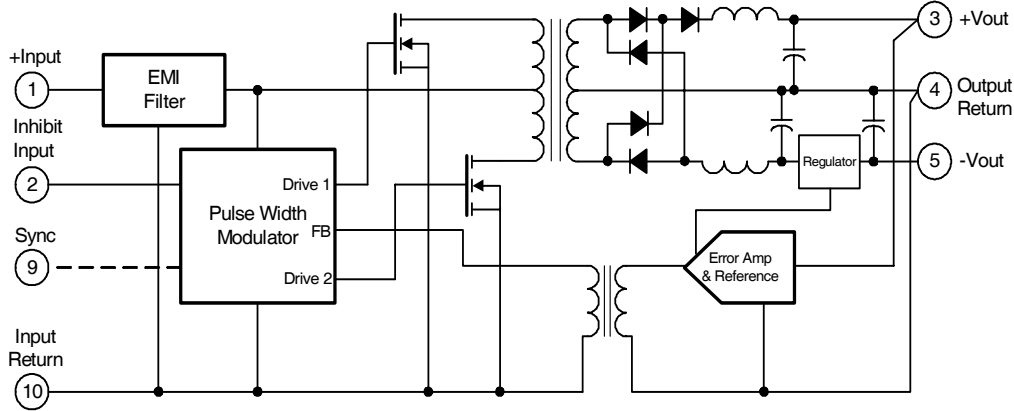

Application Information

Inhibit Function

Connecting the inhibit input (Pin 2) to input common (Pin 10) will cause the converter to shut down. It is recommended that the inhibit pin be driven by an open collector device capable of sinking at least 400µA of current. The open circuit voltage of the inhibit input is 11.5 ± 1.0VDC.

EMI Filter

An optional EMI filter (AFC461) will reduce the input ripple current to levels below the limits imposed by MIL-STD-461 CEO3.

Device Synchronization

Whenever multiple DC/DC converters are utilized in a single system, significant low frequency noise may be generated due to slight difference in the switching frequencies of the converters (beat frequency noise). Because of the low frequency nature of this noise (typically less than 10KHz), it is difficult to filter out and may interfere with proper operation of sensitive systems (communications, radar or telemetry).

International Rectifier offers an option that provides synchronization of multiple AHE/ATW converters, thus eliminating this type of noise.

To take advantage of this capability, the system designer must assign one of the converters as the master. Then, by definition, the remaining converters become slaves and will operate at the masters' switching frequency.

The user should be aware that the synchronization system is fail-safe; that is, the slaves will continue operating should the master frequency be interrupted for any reason. The layout must be such that the synchronization output (pin 9) of the master device is connected to the synchronization input (pin 9) of each slave device. It is advisable to keep this run short to minimize the possibility of radiating the 250KHz switching frequency.

The appropriate parts must be ordered to utilize this feature. After selecting the converters required for the system, a 'MSTR' suffix is added for the master converter part number and a 'SLV' suffix is added for slave part number.

Typical Synchronization Connection

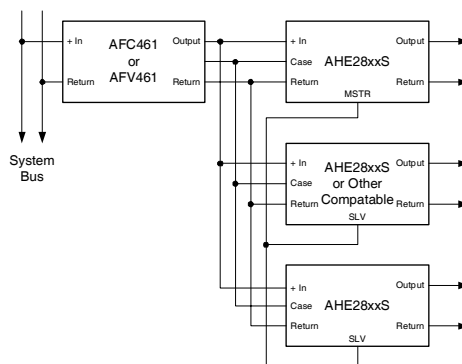

Mechanical Outlines

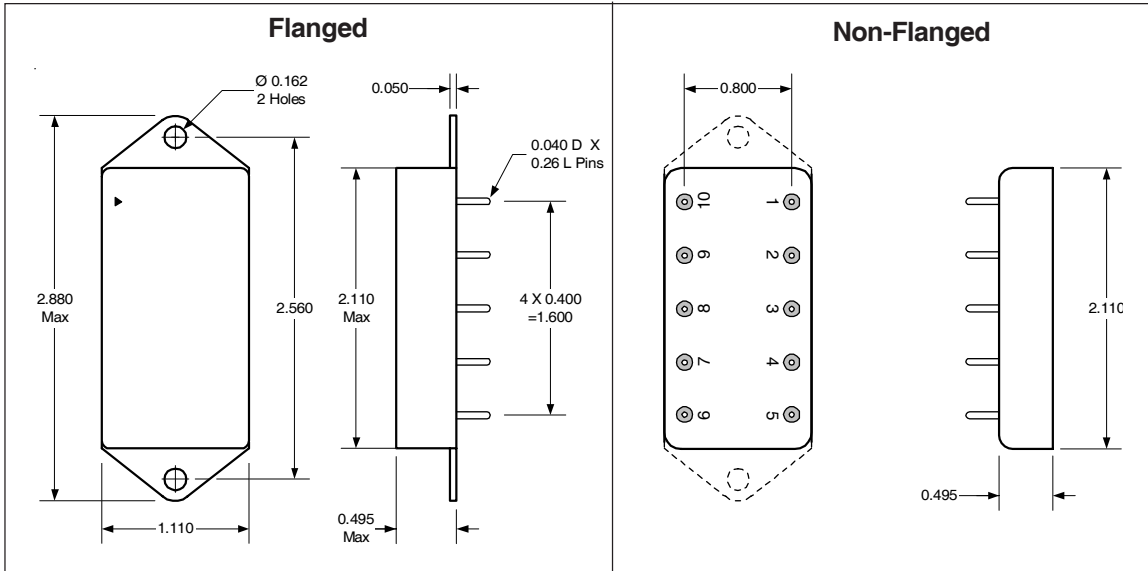

Pin Designation

| Pin # | Designation |
|-------|---------------|
| 1 | + Input |
| 2 | Inhibit Input |
| 3 | + Output |
| 4 | Output Return |
| 5 | - Output |
| 6 | NC |
| 7 | NC |
| 8 | Case Ground |
| 9 | NC or Sync. |
| 10 | Input Return |

Standard Microcircuit Drawing Equivalence Table

| Standard Microcircuit Drawing Number | Vendor Cage Code | IR Standard Part Number |
|--------------------------------------|------------------|-------------------------|
| 5962-92040 | 52467 | AHE2812D |
| 5962-91575 | 52467 | AHE2815D |

AHE28XXD Series

International
IR Rectifier

Device Screening

| Requirement | MIL-STD-883 Method | No Suffix | ES ② | HB | CH |
|------------------------------|-------------------------------|----------------|-------------------|----------------------|----------------------|
| Temperature Range | — | -20°C to +85°C | -55°C to +125°C ③ | -55°C to +125°C | -55°C to +125°C |
| Element Evaluation | MIL-PRF-38534 | N/A | N/A | N/A | Class H |
| Non-Destructive Bond Pull | 2023 | N/A | N/A | N/A | N/A |
| Internal Visual | 2017 | ① | Yes | Yes | Yes |
| Temperature Cycle | 1010 | N/A | Cond B | Cond C | Cond C |
| Constant Acceleration | 2001, Y1 Axis | N/A | 500 Gs | 3000 Gs | 3000 Gs |
| PIND | 2020 | N/A | N/A | N/A | N/A |
| Burn-In | 1015 | N/A | 48 hrs@hi temp | 160 hrs@125°C | 160 hrs@125°C |
| Final Electrical (Group A) | MIL-PRF-38534 & Specification | 25°C | 25°C ② | -55°C, +25°C, +125°C | -55°C, +25°C, +125°C |
| PDA | MIL-PRF-38534 | N/A | N/A | N/A | 10% |
| Seal, Fine and Gross | 1014 | Cond A | Cond A, C | Cond A, C | Cond A, C |
| Radiographic | 2012 | N/A | N/A | N/A | N/A |
| External Visual | 2009 | ① | Yes | Yes | Yes |

Notes:

- ① Best commercial practice
- ② Sample tests at low and high temperatures
- ③ -55°C to +105°C for AHE, ATO, ATW

Part Numbering

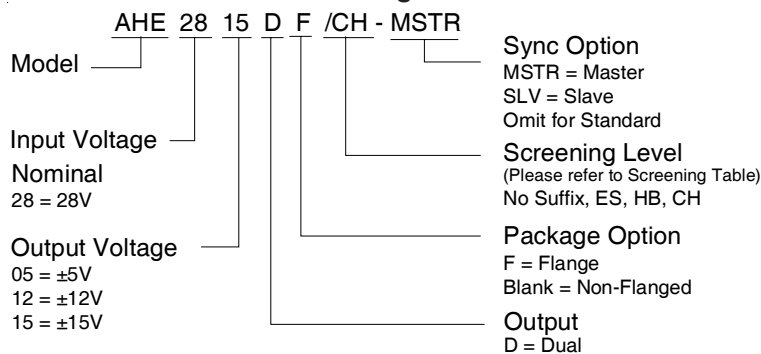

International
IR Rectifier

WORLD HEADQUARTERS: 233 Kansas St., El Segundo, California 90245, Tel: (310) 252-7105

IR SANTA CLARA: 2270 Martin Av., Santa Clara, California 95050, Tel: (408) 727-0500

Visit us at www.irf.com for sales contact information.

Data and specifications subject to change without notice. 01/2007