

## **ASA28XXS SERIES**

### **28V Input, Single Output**

## **HYBRID-HIGH RELIABILITY DC/DC CONVERTER**

### **Description**

The ASA28XXS Series of DC/DC converters are high reliability thick film hybrid converters that use flyback topology operating at a nominal frequency of 550KHz. High input to output isolation is achieved through the use of transformers in the flyback power and feedback circuits.

The advanced feedback design provides fast loop response for superior line and load transient characteristics and offers greater reliability than devices incorporating optical feedback circuits.

This device is designed to meet MIL-STD-704D input requirements offering full performance over a 16V to 40V input range. Output Power of up to 5W is available.

Connecting the inhibit pin (pin 5) to the input common (pin 7) will cause the converter to shut down. It is recommended that the inhibit pin be driven by an open collector device capable of sinking at least 400 $\mu$ A. The open circuit voltage of the inhibit pin is 11.5  $\pm$  0.5V.

Manufactured in a facility fully qualified to MIL-PRF-38534, these converters are fabricated utilizing DSCC qualified processes. For available screening options, refer to device screening table in the data sheet. Variations in electrical, mechanical and screening requirements can be accommodated. Extensive computer simulation using complex modeling allows design modifications to be examined. Contact IR Santa Clara with specific requirements.

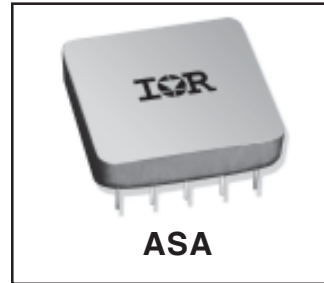

### **Features**

- Up To 5.0W Output Power
- 5V, 12V, 15V Outputs
- High Reliability
- Wide Input Voltage Range -16V To 40V
- Indefinite Short Circuit and Overload Protection
- Popular Industry Standard Pin-Out
- Military Screening Available
- Parallel Seam Welded Package
- No External Capacitors Required
- Input Voltage Surge Protected to MIL-STD-704A
- Under Voltage Lockout
- Available as Standard Military Drawing
- Standard Microcircuit Drawings Available

# ASA28XXS Series

## Specifications

International  
IRF Rectifier

Absolute Maximum Ratings	
Input voltage	-0.5V to +50VDC Continuous, 80V, 100 msec
Power output	Internally limited ( 6.5W typical )
Soldering temperature	300°C for 10 seconds
Operating case temperature	-55°C to +125°C
Storage case temperature	-65°C to +135°C

TEST	Conditions -55° ≤ T <sub>C</sub> ≤ +125°C V <sub>IN</sub> = 28V dc ±5% C <sub>L</sub> = 0 unless otherwise specified	Group A Subgroups	ASA2805S/xx		ASA2812S/xx		ASA2815S/xx		Unit
			Min	Max	Min	Max	Min	Max	
Output voltage	I <sub>OUT</sub> = 0	1	4.95	5.05	11.88	12.12	14.85	15.15	V
		2, 3	4.90	5.10	11.76	12.24	14.70	15.30	
Output current <sup>1</sup>	V <sub>IN</sub> = 16, 28, and 40 V dc	1, 2, 3		1000		417		333	mA
Output ripple voltage <sup>2</sup>	V <sub>IN</sub> = 16, 28 and 40 V dc	1		190		200		200	mV <sub>PP</sub>
		2, 3		475		290		290	
Line regulation	V <sub>IN</sub> = 16, 28, and 40 V dc I <sub>OUT</sub> = 0, 50%, 100% I <sub>MAX</sub>	1		25		±25		±25	mV
		2, 3		50		±50		±50	
Load regulation	V <sub>IN</sub> = 16, 28, and 40 V dc I <sub>OUT</sub> = 0, 50%, 100% I <sub>MAX</sub>	1		25		±25		±25	mV
		2, 3		50		±50		±50	
Input current	I <sub>OUT</sub> = 0 Pin 5 to Pin 7	1, 2, 3		18		18		18	mA
	I <sub>OUT</sub> = 0 Pin5 open			50		50		50	
Input ripple current <sup>2</sup>	I <sub>OUT</sub> = I <sub>MAX</sub>	1, 2, 3		100		100		100	mA <sub>PP</sub>
Efficiency	I <sub>OUT</sub> = I <sub>MAX</sub>	1	66		71		71		%
		2, 3			68		68		
Isolation - Input to output or any pin to case	V <sub>TEST</sub> 500 Vdc, T <sub>C</sub> = +25°C	1	100		100		100		MΩ
Capacitive load <sup>3,4</sup>	No effect on dc performance, T <sub>C</sub> = +25°C	4		500		200		200	μF
Power dissipation, load fault	Overload <sup>5</sup>	1, 2, 3		4.0		4.0		4.0	W
	Short circuit			2.0		2.0		2.0	
Switching frequency <sup>4</sup>	I <sub>OUT</sub> = I <sub>MAX</sub>	4, 5, 6	500	600	500	600	500	600	KHz
Output response to step transient load changes <sup>6</sup>	½ I <sub>MAX</sub> ⇔ I <sub>MAX</sub>	4	-300	+300	-450	+450	-400	+450	mV pk
		5, 6	-450	+450					
	0 mA ⇔ I <sub>MAX</sub>	4	-500	+500	-750	+750	-800	+750	
		5, 6	-750	+700					
Recovery time, step transient load changes	I <sub>OUT</sub> = I <sub>MAX</sub>	4, 5, 6		200		100		100	μs
	0 mA ⇔ ½ I <sub>MAX</sub>			1.0		1.0		1.0	ms
Output response transient step line changes <sup>4,8</sup>	Input step 16 ⇔ 40 V dc I <sub>OUT</sub> = I <sub>MAX</sub>	4, 5, 6		500		1000		1000	mV pk
Recovery time transient step line changes <sup>4,7,8</sup>	Input step 16 ⇔ 40 V dc I <sub>OUT</sub> = I <sub>MAX</sub>	4, 5, 6		800		800		800	μs
Turn on overshoot	I <sub>OUT</sub> = 0 mA, I <sub>MAX</sub>	4, 5, 6		600		600		600	mV pk
Turn on delay <sup>9</sup>	I <sub>OUT</sub> = 0 or I <sub>MAX</sub>	4, 5, 6		20		25		25	ms
Load fault recovery <sup>4</sup>		4, 5, 6		20		25		25	ms

For Notes to Specifications, refer to page 3

**Notes to Specifications**

1. Parameter guaranteed and measured during line and load regulation tests.
2. Bandwidth guaranteed by design. Tested for 20KHz to 2MHz.
3. Capacitive load may be any value from 0 to the maximum limit without compromising dc performance. A capacitive load in excess of the maximum limit will not disturb loop stability but may interfere with the operation of the load fault detection circuitry, appearing as a short circuit during turn-on.
4. Parameter shall be tested as part of design characterization and after design or process changes.
5. An overload is that condition of load in excess of rated load but less than that necessary to trigger the short circuit protection and is the condition of maximum power dissipation.
6. Load step transition time between 2 $\mu$ s and 10 $\mu$ s.
7. Recovery time is measured from the initiation of the transient to where  $V_{OUT}$  has returned to within  $\pm 1\%$  of  $V_{OUT}$  at 50% load.
8. Input step transition time between 2 $\mu$ s and 10 $\mu$ s.
9. Turn-on delay time measurement is for either a step application of power at the input or the removal of a ground signal from the inhibit pin (pin 2) while power is applied to the input.

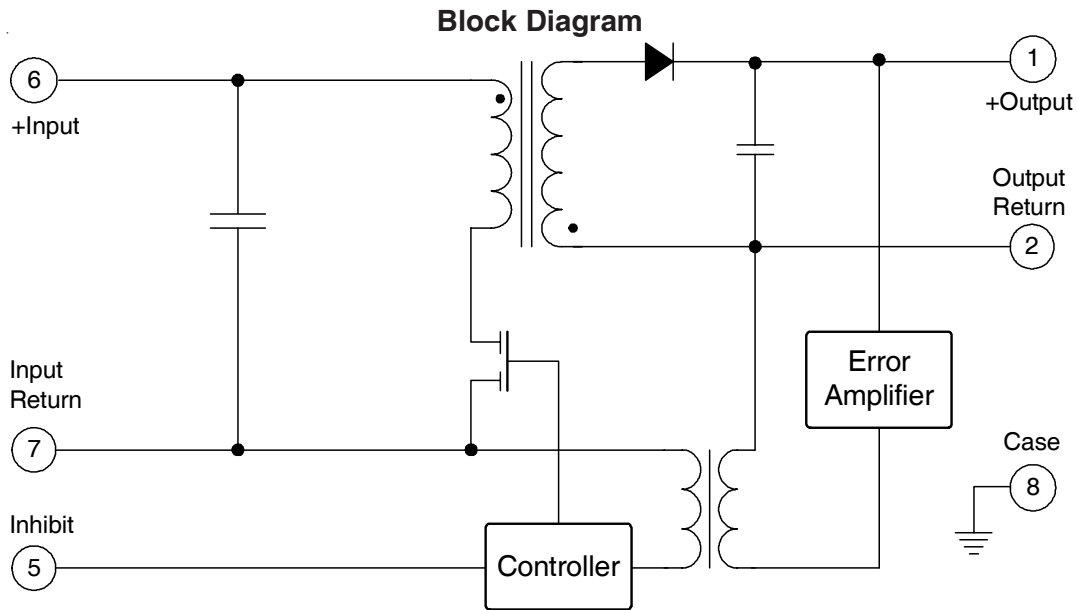

**Standard Microcircuit Drawing Equivalence Table**

Standard Microcircuit Drawing Number	IR Standard Part Number
5962-94629	ASA2805S
5962-94630	ASA2815S
5962-94631	ASA2812S

**Mechanical Outline**

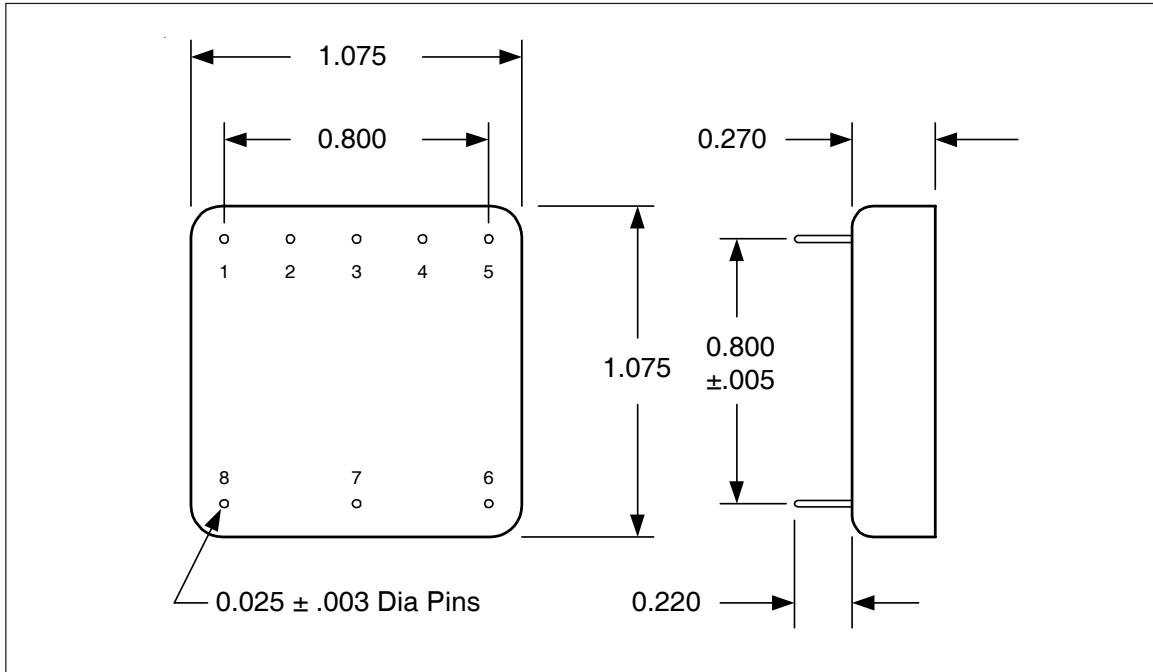

**Pin Designation**

Pin #	Designation
1	+ Output
2	Output Return
3	NC
4	NC
5	Inhibit
6	+ Input
7	Input Return
8	Case Ground

**Device Screening**

Requirement	MIL-STD-883 Method	No Suffix	ES ②	HB	CH
Temperature Range	—	-20°C to +85°C	-55°C to +125°C ③	-55°C to +125°C	-55°C to +125°C
Element Evaluation	MIL-PRF-38534	N/A	N/A	N/A	Class H
Non-Destructive Bond Pull	2023	N/A	N/A	N/A	N/A
Internal Visual	2017	①	Yes	Yes	Yes
Temperature Cycle	1010	N/A	Cond B	Cond C	Cond C
Constant Acceleration	2001, Y1 Axis	N/A	500 Gs	3000 Gs	3000 Gs
PIND	2020	N/A	N/A	N/A	N/A
Burn-In	1015	N/A	48 hrs@hi temp	160 hrs@125°C	160 hrs@125°C
Final Electrical ( Group A )	MIL-PRF-38534 & Specification	25°C	25°C ②	-55°C, +25°C, +125°C	-55°C, +25°C, +125°C
PDA	MIL-PRF-38534	N/A	N/A	N/A	10%
Seal, Fine and Gross	1014	Cond A	Cond A, C	Cond A, C	Cond A, C
Radiographic	2012	N/A	N/A	N/A	N/A
External Visual	2009	①	Yes	Yes	Yes

**Notes:**

- ① Best commercial practice
- ② Sample tests at low and high temperatures
- ③ -55°C to +105°C for AHE, ATO, ATW

**Part Numbering**

