

ATW28XXS SERIES

28V Input, Single Output

HYBRID-HIGH RELIABILITY DC/DC CONVERTER

Description

The ATW28XXS Series of DC/DC converters feature high power density and an extended temperature range for use in military and industrial applications. Designed to MIL-STD-704 input requirements, these devices operate with a nominal 28VDC input and are available with single outputs at 5V, 12V and 15V. The circuit design incorporates a pulse width modulated push-pull topology operating in the feed-forward mode at a nominal switching frequency of 270KHz. Input to output isolation is achieved through the use of transformers in the forward and feedback circuits.

The advanced feedback design provides fast loop response for superior line and load transient characteristics and offers greater reliability and radiation tolerance than devices incorporating optical elements in the feedback circuits.

Three standard temperature grades are offered. Refer to Part Number section. These devices are provided in a flanged package for secure mounting in severe environments.

Manufactured in a facility fully qualified to MIL-PRF-38534, these converters are fabricated utilizing DSCC qualified processes. For available screening options, refer to device screening table in the data sheet. Variations in electrical, mechanical and screening can be accommodated. Contact IR Santa Clara for special requirements.

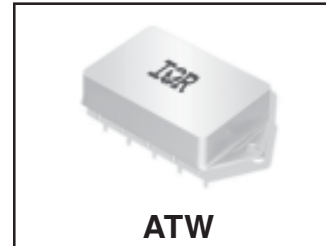

Features

- 19V to 40VDC Input Range (28VDC Nominal)
- 30W Output Power
- Indefinite Short Circuit and Overload Protection
- 22.8W/in³ Power Density
- Fast Loop Response for Superior Transient Characteristics
- Operating Temperature Range from -55°C to +125°C Available
- Popular Industry Standard Pin-Out
- Resistance Seam Welded Case for Superior Long Term Hermeticity
- Efficiencies up to 83%
- Shutdown from External Signal
- Military Screening
- 250,000 hour MTBF at 85°C
- Standard Microcircuit Drawings Available

Specifications

ATW2805S

Absolute Maximum Ratings	
Input voltage	-0.5V to +50VDC
Soldering temperature	300°C for 10 seconds
Operating case temperature	-55°C to +125°C
Storage case temperature	-65°C to +135°C

Table I. Electrical Performance Characteristics

Test	Symbol	Conditions -55°C ≤ T _c ≤ +125°C V _{in} = 28 Vdc ±5%, C _L = 0 Unless otherwise specified	Group A Subgroups	Device Types	Limits		Unit
					Min	Max	
Output voltage	V _{OUT}	I _{OUT} = 0	1	All	4.95	5.05	V
			2,3		4.90	5.10	
Output current ¹	I _{OUT}	V _{IN} = 19, 28, and 40 V dc	1,2,3	All	0	6000	mA
Output ripple voltage ²	V _{RIP}	V _{IN} = 19, 28, and 40 V dc, B.W. = dc to 2MHz	1,2,3	All		50	mVp-p
Output power ^{1,3}	P _{OUT}	V _{IN} = 19,28, and 40 V dc	1,2,3	All	30		W
Line regulation ⁴	VR _{LINE}	V _{IN} = 19, 28, and 40 V dc, I _{OUT} = 0, 3000, and 6000mA	1	All		5.0	mV
			2,3		20		
Load regulation ⁴	VR _{LOAD}	V _{IN} = 19, 28, and 40 V dc, I _{OUT} = 0, 3000, and 6000mA	1,2,3	All		30	mV
Input current	I _{IN}	I _{OUT} = 0, inhibit (pin 2) tied to input return (pin 10)	1,2,3	All		18	mA
		I _{OUT} = 0, inhibit (pin 2) = open			40		
Input ripple current ²	I _{RIP}	I _{OUT} = 6000mA B.W. = dc to 2MHz	1,2,3	All		20	mAp-p
Efficiency	E _{FF}	I _{OUT} = 6000mA T _C = +25°C	1	All	78		%
Isolation	ISO	Input to output or any pin to case (except pin 7) at 500 V dc T _C = +25°C	1	All	100		MΩ
Capacitive load ^{5,6}	C _L	No effect on dc performance, T _C = +25°C	4	All		500	μF
Power dissipation load fault	P _D	Overload, T _C = +25°C ⁷	1	All		12	W
		Short circuit, T _C = +25°C			9.0		
Switching frequency	F _S	I _{OUT} = 6000mA	4,5,6	01	250	300	KHz
				02	250	270	
				03	275	300	
Output response to step transient load changes ⁸	VO _{TLOAD}	4000mA to/from 6000mA	4,5,6	All	-500	+500	mVpk
		500mA to/from 2500mA			4,5,6	-500	

For Notes to Specifications, refer to page 3

Table I. Electrical Performance Characteristics - continued

ATW2805S

Test	Symbol	Conditions -55°C ≤ Tc ≤ +125°C Vin = 28 Vdc ±5%, CL = 0 unless otherwise specified	Group A Subgroups	Device Types	Limits		Unit
					Min	Max	
Recovery time step transient load changes ^{8,9}	TT _{LOAD}	4000mA to/from 6000mA	4	All		100	μs
			5,6			200	
		500mA to 2500mA	4	All		100	
			5,6			200	
Turn on overshoot	VTon _{OS}	I _{OUT} = 0 and 6000mA	4,5,6	All		500	mV pk
Turn on delay ¹⁰	Ton _D	I _{OUT} = 0 and 6000mA	4,5,6	All		12	ms
Load fault recovery ^{6,10}	Tr _{LF}		4,5,6	All		12	ms

Notes to Specifications

- 1 Parameter guaranteed by line and load regulation tests.
- 2 Bandwidth guaranteed by design. Tested for 20kHz to 2.0MHz.
- 3 Above +125°C case, derate output power linearly to 0 at +135°C.
- 4 Output voltage measured at load with remote sense leads connected across load.
- 5 Capacitive load may be any value from 0 to the maximum limit without compromising dc performance. A capacitive load in excess of the maximum limit will not disturb loop stability but may interfere with the operation of the load fault detection circuitry, appearing as a short circuit during turn-on.
- 6 Parameter shall be tested as part of design characterization and after design or process changes. Thereafter, parameters shall be guaranteed to the limits specified in Table I.
- 7 An overload is that condition with a load in excess of the rated load but less than that necessary to trigger the short circuit protection and is the condition of maximum power dissipation.
- 8 Load step transition time between 2.0μs and 10μs.
- 9 Recovery time is measured from the initiation of the transient to where V_{OUT} has returned to within ±1.0% of V_{OUT} at 50% load.
- 10 Turn-on delay time measurement is for either a step application of power at the input or the removal of ground signal from the inhibit pin (pin 1) while power is applied to the input is unlimited.

Specifications

ATW2812S

Absolute Maximum Ratings	
Input voltage	-0.5V to +50VDC
Soldering temperature	300°C for 10 seconds
Operating case temperature	-55°C to +125°C
Storage case temperature	-65°C to +135°C

Table II. Electrical Performance Characteristics

Test	Symbol	Conditions -55°C ≤ T _c ≤ +125°C V _{in} = 28 Vdc ±5%, C _L = 0 Unless otherwise specified	Group A Subgroups	Device Types	Limits		Unit
					Min	Max	
Output voltage	V _{OUT}	I _{OUT} = 0	1	All	11.88	12.12	V
			2,3		11.76	12.24	
Output current ¹	I _{OUT}	V _{IN} = 18, 28, and 40 V dc	1,2,3	All		2500	mA
Output ripple voltage ²	V _{RIP}	V _{IN} = 18, 28, and 40 V dc, B.W. = 20Hz to 2MHz	1,2,3	All		50	mVp-p
Line regulation	V _{RLINE}	V _{IN} = 18, 28, and 40 V dc, I _{out} = 0, 1250, and 2500mA	1	All		±30	mV
			2,3		±60		
Load regulation	V _{RLOAD}	V _{IN} = 18, 28, and 40 V dc, I _{OUT} = 0, 1250, and 2500mA	1,2,3	All		±120	mV
Input current	I _{IN}	I _{OUT} = 0, inhibit (pin 2) tied to input return (pin 10)	1,2,3	All		18	mA
		I _{OUT} = 0, inhibit (pin 2) = open			50		
Input ripple current ²	I _{RIP}	I _{OUT} = 2500mA B.W. = 20Hz to 2MHz	1,2,3	All		20	mAp-p
Efficiency	E _{FF}	I _{OUT} = 2500mA	1	All	78		%
			2,3		75		
Isolation	ISO	Input to output or any pin to case (except pin 7) at 500 V dc T _c = +25°C	1	All	100		MΩ
Capacitive load ^{3,4}	C _L	No effect on dc performance, T _c = +25°C	4	All		200	μF
Power dissipation load fault	P _D	Overload ⁵	1	All		12	W
		Short circuit	1,2,3		9.0		
Switching frequency	F _S	I _{OUT} = 2500mA	4,5,6	01	250	300	KHz
				02	250	270	
				03	275	300	
Output response to step transient load changes ⁶	V _{OLOAD}	1250mA to/from 2500mA	4,5,6	All	-800	+800	mVpk
		0mA to/from 1250mA			-1000	+1000	

For Notes to Specifications, refer to page 5

Table II. Electrical Performance Characteristics - continued

ATW2812S

Test	Symbol	Conditions -55°C ≤ T _C ≤ +125°C V _{in} = 28 Vdc ±5%, C _L = 0 unless otherwise specified	Group A Subgroups	Device Types	Limits		Unit
					Min	Max	
Recovery time step transient load changes ^{6, 7}	T _{TLOAD}	1250mA to/from 2500mA	4	All		100	μs
			5,6		200		
		0mA to 1250mA	4	All		5.0	ms
			5,6			10	
Output response to Transient step Line changes	V _{O_TLINE}	Input step 18V to/ from 40V dc, I _{OUT} = 2500mA ^{4, 8}	4,5,6	All	-1000	+1000	mVpk
Recovery time Transient step Line changes	T _{TLINE}	Input step 18V to/ from 40V dc I _{OUT} = 2500mA ^{4, 7, 8}	4,5,6	All		500	μs
Turn on overshoot	V _{TonOS}	I _{OUT} = 0 and 2500mA	4,5,6	All		600	mVpk
Turn on delay	T _{onD}	I _{OUT} = 0 and 2500mA ⁹	4,5,6	All		12	ms
Load fault recovery ^{4, 9}	T _{rLF}		4,5,6	All		12	ms

Notes to Specifications

- Parameter guaranteed by line and load regulation tests.
- Bandwidth guaranteed by design. Tested for 20kHz to 2.0MHz.
- Capacitive load may be any value from 0 to the maximum limit without compromising dc performance.
A capacitive load in excess of the maximum limit will not disturb loop stability but may interfere with the operation of the load fault detection circuitry, appearing as a short circuit during turn-on.
- Parameter shall be tested as part of design characterization and after design or process changes.
Thereafter, parameters shall be guaranteed to the limits specified in Table II.
- An overload is that condition with a load in excess of the rated load but less than that necessary to trigger the short circuit protection and is the condition of maximum power dissipation.
- Load step transition time between 2.0μs and 10μs.
- Recovery time is measured from the initiation of the transient to where V_{OUT} has returned to within ±1.0% of V_{OUT} at 50% load.
- Input step transition time between 2.0μs and 10μs.
- Turn-on delay time measurement is for either a step application of power at the input or the removal of ground signal from the inhibit pin (pin 2) while power is applied to the input.

Specifications

ATW2815S

Absolute Maximum Ratings	
Input voltage	-0.5V to +50VDC
Soldering temperature	300°C for 10 seconds
Operating case temperature	-55°C to +125°C
Storage case temperature	-65°C to +135°C

Table III. Electrical Performance Characteristics

Test	Symbol	Conditions -55°C ≤ T _c ≤ +125°C V _{in} = 28 Vdc ±5%, C _L = 0 Unless otherwise specified	Group A Subgroups	Device Types	Limits		Unit
					Min	Max	
Output voltage	V _{OUT}	I _{OUT} = 0	1	All	14.85	15.15	V
			2,3		14.70	15.30	
Output current ¹	I _{OUT}	V _{IN} = 17, 28, and 40 V dc	1,2,3	All	0	1333	mA
Output ripple voltage ²	V _{RIP}	V _{IN} = 17, 28, and 40 V dc, B.W. = dc to 2MHz	1,2,3	All		60	mV _{p-p}
Output power ^{1,3}	P _{OUT}	V _{IN} = 17,28, and 40 V dc	1,2,3	All	20		W
Line regulation	VR _{LINE}	V _{IN} = 17, 28, and 40 V dc, I _{out} = 0, 677, and 1333mA	1	All		35	mV
			2,3			75	
Load regulation	VR _{LOAD}	V _{IN} = 17, 28, and 40 V dc, I _{OUT} = 0, 677, and 1333mA	1,2,3	All		150	mV
Input current	I _{IN}	I _{OUT} = 0, inhibit (pin 2) tied to input return (pin 10)	1,2,3	All		18	mA
		I _{OUT} = 0, inhibit (pin 2) = open				35	
Input ripple current ²	I _{RIP}	I _{OUT} = 1333mA B.W. = dc to 2MHz	1,2,3	All		50	mA _{p-p}
Efficiency	E _{FF}	I _{OUT} = 1333mA T _C = +25°C	1	All	80		%
Isolation	ISO	Input to output or any pin to case (except pin 8) at 500 V dc T _C = +25°C	1	All	100		MΩ
Capacitive load ^{4,5}	C _L	No effect on dc performance, T _C = +25°C	4	All		200	μF
Power dissipation load fault	P _D	Overload, T _C = +25°C ⁶	1	All		6.0	W
		Short circuit, T _C = +25°C				6.0	
Switching frequency	F _S	I _{OUT} = 1333mA	4,5,6	01	225	275	KHz
				02	225	245	
				03	250	275	
Output response to step transient load changes ⁷	VO _{TLOAD}	50% load to/from 100% load	4	All	-300	+300	mVpk
			5,6		-450	+450	
		No load to/from 50% load	4		-500	+500	
			5,6		-750	+750	

For Notes to Specifications, refer to page 7

Table III. Electrical Performance Characteristics - continued

ATW2815S

Test	Symbol	Conditions -55°C ≤ T _c ≤ +125°C V _{in} = 28 Vdc ±5%, C _L = 0 unless otherwise specified	Group A Subgroups	Device Types	Limits		Unit
					Min	Max	
Recovery time step transient load changes ^{7,8}	TT _{LOAD}	50% load to/from 100% load	4	All		70	μs
			5,6			100	
		No load to 50% load	4,5,6			1500	
		50% load to no load	4,5,6			5.0	
Output response to transient step line changes ^{5,9}	VO _{TLINE}	Input step 17 to 40 Vdc	4,5,6	All		500	mVpk
		Input step 40 to 17 Vdc	4,5,6			1500	
Recovery time transient line changes ^{5,8,9}	TT _{LINE}	Input step 17 to 40 Vdc	4,5,6	All		800	ms
		Input step 40 to 17 Vdc	4,5,6			800	
Turn on overshoot	V _{TonOS}	I _{OUT} = 0 and 1333mA	4,5,6	All		600	mVpk
Turn on delay ¹⁰	T _{onD}	I _{OUT} = 0 and 1333mA	4,5,6	All		10	ms
Load fault recovery ⁵	T _{rLF}		4,5,6	All		10	ms
Weight		Flange				75	g

Notes to Specifications

- 1 Parameter guaranteed by line and load regulation tests.
- 2 Bandwidth guaranteed by design. Tested for 20kHz to 2.0MHz.
- 3 For operation at 16 Vdc input, derate output power by 33%.
- 4 Capacitive load may be any value from 0 to the maximum limit without compromising dc performance.
A capacitive load in excess of the maximum limit will not disturb loop stability but may interfere with the operation of the load fault detection circuitry, appearing as a short circuit during turn-on.
- 5 Parameter shall be tested as part of design characterization and after design or process changes.
Thereafter, parameters shall be guaranteed to the limits specified in Table III.
- 6 An overload is that condition with a load in excess of the rated load but less than that necessary to trigger the short circuit protection and is the condition of maximum power dissipation.
- 7 Load step transition time between 2.0μs and 10μs.
- 8 Recovery time is measured from the initiation of the transient to where V_{OUT} has returned to within ±1.0% of V_{OUT} at 50% load.
- 9 Input step transition time between 2.0μs and 10μs.
- 10 Turn-on delay time measurement is for either a step application of power at the input or the removal of ground signal from the inhibit pin (pin 2) while power is applied to the input.

Block Diagram

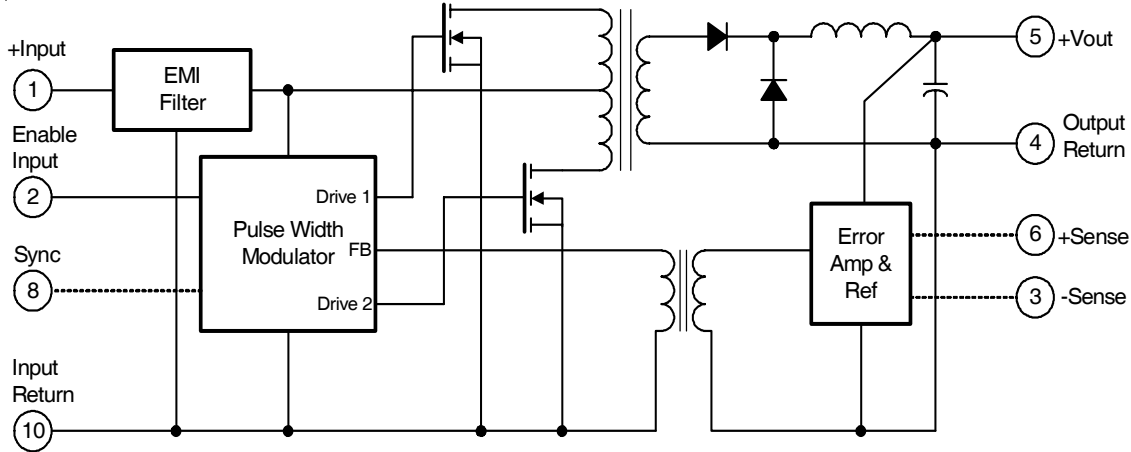

Application Information

Inhibit Function (Enable)

Connecting the inhibit input (Pin 2) to input common (Pin 10) will cause the converter to shut down. It is recommended that the inhibit pin be driven by an open collector device capable of sinking at least 400µA of current. The open circuit voltage of the inhibit input is 11.5 ±1.0VDC.

EMI Filter

An optional EMI filter (AFC461) will reduce the input ripple current to levels below the limits imposed by MIL-STD-461 CEO3.

Remote Sense (ATW2805S only)

Better than 0.1% line and load regulation (case temperature constant) are typical when the remote sense leads are used. If the remote sense leads are left unconnected, then the output voltage (measured at pins 4 and 5) will rise to approximately 5.4VDC. If the remote sense leads are shorted together, the output voltage may rise above 10VDC depending on load, possibly damaging both the converter and load.

Device Synchronization

Whenever multiple DC/DC converters are utilized in a single system, significant low frequency noise may be generated due to the slight differences in the switching frequencies of the converters (beat frequency noise). Because of the low frequency nature of this noise (typically less than 10KHz), it is difficult to filter out and may interfere with proper operation of sensitive systems (communications, radar or telemetry). International Rectifier offers an option, which provides synchronization of multiple AHE/ATW type converters, thus eliminating this type of noise.

To take advantage of this capability, the system designer must assign one of the converters as the master. Then, by definition, the remaining converters become slaves and will operate at the masters' switching frequency.

The user should be aware that the synchronization system is fail-safe; that is, the slaves will continue operating should the master frequency be interrupted for any reason. The layout must be such that the synchronization output (pin 8) of the master device is connected to the synchronization input (pin 8) of each slave device. It is advisable to keep this run short to minimize the possibility of radiating the 250KHz switching frequency.

The appropriate parts must be ordered to utilize this feature. After selecting the converters required for the system, a 'MSTR' suffix is added for the master converter part number and a 'SLV' suffix is added for slave part number. See Part Number section.

Typical Synchronization Connection

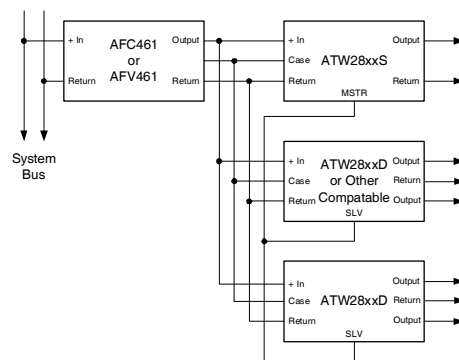

Mechanical Outline

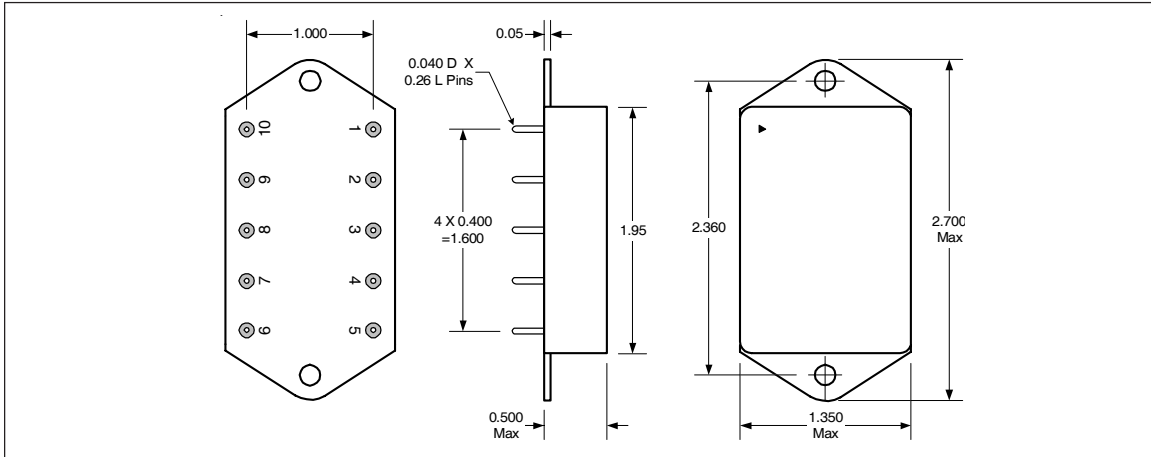

Pin Designation

Pin #	Designation
1	+ Input
2	Enable Input
3	- Remote Sense *
4	Output Return
5	+ Output
6	+ Remote Sense *
7	Case Ground
8	NC (or Sync. Option)
9	NC
10	Input Return

* ATW2805S only. ATW2812S, ATW2815S have NC

Standard Microcircuit Drawing Equivalence Table

Standard Microcircuit Drawing Number	Vendor Cage Code	IR Standard Part Number
5962-91579	52467	ATW2805S
5962-92110	52467	ATW2812S
5962-91599	52467	ATW2815S

ATW28XXS Series

International
IOR Rectifier

Device Screening

Requirement	MIL-STD-883 Method	No Suffix	ES ②	HB	CH
Temperature Range	—	-20°C to +85°C	-55°C to +125°C ③	-55°C to +125°C	-55°C to +125°C
Element Evaluation	MIL-PRF-38534	N/A	N/A	N/A	Class H
Non-Destructive Bond Pull	2023	N/A	N/A	N/A	N/A
Internal Visual	2017	①	Yes	Yes	Yes
Temperature Cycle	1010	N/A	Cond B	Cond C	Cond C
Constant Acceleration	2001, Y1 Axis	N/A	500 Gs	3000 Gs	3000 Gs
PIND	2020	N/A	N/A	N/A	N/A
Burn-In	1015	N/A	48 hrs@hi temp	160 hrs@125°C	160 hrs@125°C
Final Electrical (Group A)	MIL-PRF-38534 & Specification	25°C	25°C ②	-55°C, +25°C, +125°C	-55°C, +25°C, +125°C
PDA	MIL-PRF-38534	N/A	N/A	N/A	10%
Seal, Fine and Gross	1014	Cond A	Cond A, C	Cond A, C	Cond A, C
Radiographic	2012	N/A	N/A	N/A	N/A
External Visual	2009	①	Yes	Yes	Yes

Notes:

- ① Best commercial practice
- ② Sample tests at low and high temperatures
- ③ -55°C to +105°C for AHE, ATO, ATW

Part Numbering

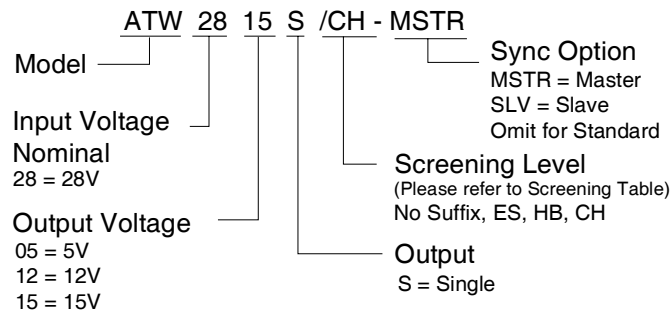

International
IOR Rectifier

WORLD HEADQUARTERS: 233 Kansas St., El Segundo, California 90245, Tel: (310) 252-7105
IR SANTA CLARA: 2270 Martin Av., Santa Clara, California 95050, Tel: (408) 727-0500
Visit us at www.irf.com for sales contact information.

Data and specifications subject to change without notice. 12/2006