

**ASA28XXD SERIES**  
**28V Input, Dual Output**

**HYBRID-HIGH RELIABILITY**  
**DC/DC CONVERTER**

**Description**

The ASA28XXD Series of DC/DC converters are high reliability thick film hybrid converters that use flyback topology operating at a nominal frequency of 550KHz. High input to output isolation is achieved through the use of transformers in the flyback power and feed back circuits.

The advanced feedback design provides fast loop response for superior line and load transient characteristics and offers greater reliability than devices incorporating optical feedback circuits.

This device is designed to meet MIL-STD-704 input requirements offering full performance over a 16V to 40V input range. Output Power of up to 5W is available for either balanced or unbalanced loads.

Connecting the inhibit pin (pin 5) to the input common (pin 7) will cause the converter to shut down. It is recommended that the inhibit pin be driven by an open collector device capable of sinking at least 400 $\mu$ A. The open circuit voltage of the inhibit pin is 11.5  $\pm$  0.5V.

Manufactured in a facility fully qualified to MIL-PRF-38534, these converters are fabricated utilizing DSCC qualified processes. For available screening options, refer to device screening table in the data sheet. Variations in electrical, mechanical and screening can be accommodated. Extensive computer simulation using complex modeling enables rapid design modification to be provided. Contact IR Santa Clara with specific requirements.

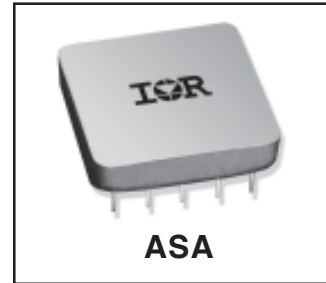

**Features**

- Up To 5.0W Output Power
- $\pm$ 5V,  $\pm$ 12V,  $\pm$ 15V Outputs
- High Reliability
- Wide Input Voltage Range -16V To 40V
- Indefinite Short Circuit and Overload Protection
- Popular Industry Standard Pin-Out
- Military Screening
- Parallel Seam Welded Package
- No External Capacitors Required
- Input Voltage Surge Protected to MIL-STD-704
- Under Voltage Lockout
- Standard Microcircuit Drawings Available

# ASA28XXD Series

## Specifications

International  
IRF Rectifier

Absolute Maximum Ratings	
Input voltage	-0.5V to +50VDC Continuous, 80V, 100 msec
Power output	Internally limited ( 6.5W typical )
Soldering temperature	300°C for 10 seconds
Operating case temperature	-55°C to +125°C
Storage case temperature	-65°C to +135°C

TEST	Conditions -55° ≤ T <sub>c</sub> ≤ +125°C V <sub>IN</sub> = 28V dc ±5% C <sub>L</sub> = 0 unless otherwise specified	Group A Subgroups	ASA2805D/XX		ASA2812D/XX		ASA2815D/XX		Unit
			Min	Max	Min	Max	Min	Max	
Output voltage	I <sub>OUT</sub> = 0	1	±4.95	±5.05	±11.88	±12.12	±14.85	±15.15	V
		2, 3	±4.90	±5.10	±11.76	±12.24	±14.70	±15.30	
Output current <sup>1, 2</sup>	V <sub>IN</sub> = 16, 28, and 40 V dc either output	1, 2, 3	200	1000	84	333	67	267	mA
Output ripple voltage <sup>3, 4</sup>	V <sub>IN</sub> = 16, 28 and 40 V dc	1, 2, 3		470		200		290	mV <sub>pp</sub>
Line regulation <sup>4</sup>	V <sub>IN</sub> = 16, 28, and 40 V dc I <sub>OUT</sub> = 0, 50%, 100% I <sub>MAX</sub>	1, 2, 3		50		50		50	mV
Load regulation <sup>4</sup>	V <sub>IN</sub> = 16, 28, and 40 V dc I <sub>OUT</sub> = 0, 50%, 100% I <sub>MAX</sub>	1, 2, 3		50		50		50	mV
Cross regulation <sup>5</sup>	20% to 80% load change	1, 2, 3		15		8.0		8.0	%
Input current	I <sub>OUT</sub> = 0 Pin 5 connected to pin 7	1, 2, 3		12		12		12	mA
	I <sub>OUT</sub> = 0 Pin5 open			60		60		60	
Input ripple current <sup>3, 4</sup>	I <sub>OUT</sub> = I <sub>MAX</sub>	1, 2, 3		100		100		100	mA <sub>pp</sub>
Efficiency <sup>4</sup>	I <sub>OUT</sub> = I <sub>MAX</sub>	1, 3	70		71		71		%
		2	66		68		68		
Isolation	Input to output or any pin to case (except pin 8) at 500 V dc, T <sub>c</sub> = +25° C	1	100		100		100		MΩ
Capacitive load <sup>6, 7</sup>	No effect on dc performance, total for both outputs	4	200			200		200	μF
Power dissipation load fault	Overload <sup>B</sup>	1, 2, 3		4.0		4.0		4.0	W
	Short circuit			2.0		2.0		2.0	
Switching frequency <sup>4</sup>	I <sub>OUT</sub> = I <sub>MAX</sub>	4, 5, 6	500	600	500	600	500	600	KHz
Output response to step transient load changes <sup>4, 9</sup>	I <sub>OUT</sub> = 50% ⇄ 100% I <sub>MAX</sub>	4, 5, 6	-400	+400	-400	+400	-400	+400	mV pk
	I <sub>OUT</sub> = 0 ⇄ 50% I <sub>MAX</sub>		-800	+800	-800	+800	-800	+800	
Recovery time, step transient load changes <sup>4, 9, 10</sup>	I <sub>OUT</sub> = 50% ⇄ 100% I <sub>MAX</sub>	4, 5, 6		100		100		100	μs
	I <sub>OUT</sub> = 0 ⇄ 50% I <sub>MAX</sub>			2000		2000		2000	
Output response transient step line changes <sup>4, 7, 11</sup>	V <sub>IN</sub> = 16 ⇄ 40Vdc, I <sub>OUT</sub> = I <sub>MAX</sub>	4, 5, 6	-750	+750	- 750	+750	-750	+750	mV pk
Recovery time transient step line changes <sup>4, 7, 10, 11</sup>	V <sub>IN</sub> = 16 ⇄ 40Vdc, I <sub>OUT</sub> = I <sub>MAX</sub>	4, 5, 6		1200		1200		1200	μs
Turn on overshoot <sup>4</sup>	I <sub>OUT</sub> = 0 and I <sub>MAX</sub>	4, 5, 6		600		600		600	mV pk
Turn on delay <sup>4, 12</sup>	I <sub>OUT</sub> = 0 and I <sub>MAX</sub>	4, 5, 6		25		25		25	ms
Load fault recovery <sup>7</sup>		4, 5, 6		25		25		25	ms

For Notes to Specifications, refer to page 3

**Notes to Specifications**

1. Parameter guaranteed by line, load, and cross regulation tests.
2. Up to 80% of full power is available from either output provided the total output does not exceed 5W.
3. Bandwidth of DC to 20MHz is guaranteed by design. Tested for 20KHz to 2MHz.
4. Load current split equally between +V<sub>OUT</sub> and -V<sub>OUT</sub>.
5. 1.0W load on output under test, 1.0W to 4.0W load change on other output.
6. Capacitive load may be any value from 0 to the maximum limit without compromising DC performance. A capacitive load in excess of the maximum limit will not disturb loop stability but may interfere with the operation of the load fault detection circuitry, appearing as a short circuit during turn-on.
7. Parameter shall be tested as part of design characterization and after design or process changes. Thereafter, parameters shall be guaranteed to the limits specified.
8. An overload is a condition with a load in excess of rated but less than that necessary to trigger the short circuit protection and is the condition of maximum power dissipation.
9. Load step transition time between 2μs and 10μs.
10. Recovery time is measured from the initiation of the transient to where V<sub>OUT</sub> has returned to within ±1% of V<sub>OUT</sub> at 50% load.
11. Input step transition time between 2μs and 10μs.
12. Turn-on delay time measurements is for either a step application of power at the input or the removal of ground connection from enable pin (pin 5) with power applied to the input.

**Block Diagram**

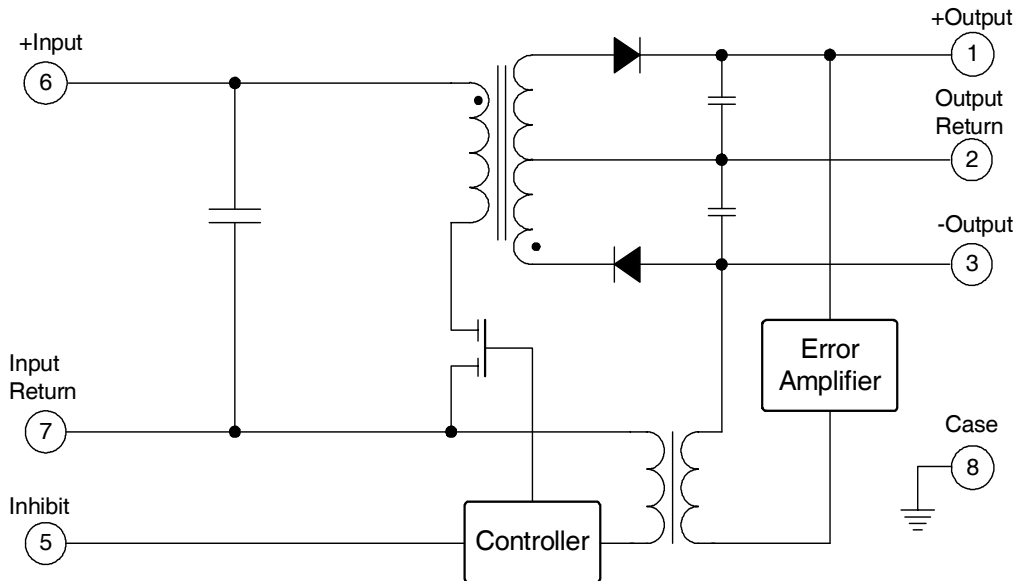

**Mechanical Outline**

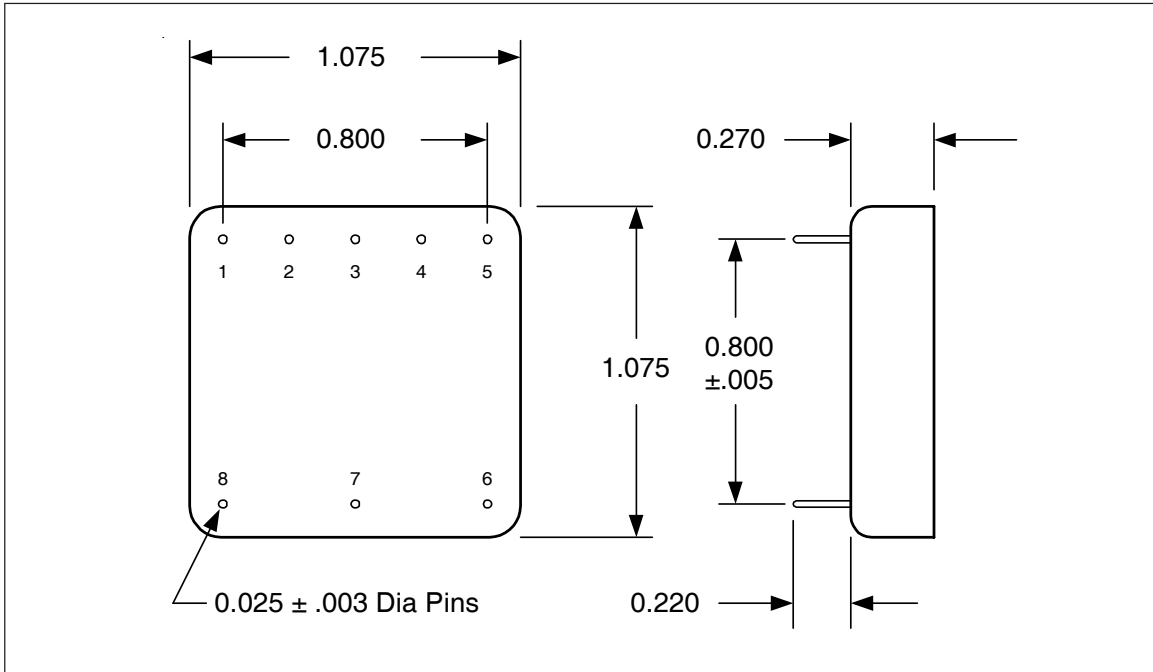

**Pin Designation**

Pin #	Designation
1	+ Output
2	Output Return
3	- Output
4	NC
5	Inhibit
6	+ Input
7	Input Return
8	Case Ground

**Standard Microcircuit Drawing Equivalence Table**

Standard Microcircuit Drawing Number	IR Standard Part Number
5962-94649	ASA2815D
5962-95648	ASA2812D

**Device Screening**

Requirement	MIL-STD-883 Method	No Suffix	ES ②	HB	CH
Temperature Range	—	-20°C to +85°C	-55°C to +125°C ③	-55°C to +125°C	-55°C to +125°C
Element Evaluation	MIL-PRF-38534	N/A	N/A	N/A	Class H
Non-Destructive Bond Pull	2023	N/A	N/A	N/A	N/A
Internal Visual	2017	⓪	Yes	Yes	Yes
Temperature Cycle	1010	N/A	Cond B	Cond C	Cond C
Constant Acceleration	2001, Y1 Axis	N/A	500 Gs	3000 Gs	3000 Gs
PIND	2020	N/A	N/A	N/A	N/A
Burn-In	1015	N/A	48 hrs@hi temp	160 hrs@125°C	160 hrs@125°C
Final Electrical ( Group A )	MIL-PRF-38534 & Specification	25°C	25°C ②	-55°C, +25°C, +125°C	-55°C, +25°C, +125°C
PDA	MIL-PRF-38534	N/A	N/A	N/A	10%
Seal, Fine and Gross	1014	Cond A	Cond A, C	Cond A, C	Cond A, C
Radiographic	2012	N/A	N/A	N/A	N/A
External Visual	2009	⓪	Yes	Yes	Yes

**Notes:**

- ⓪ Best commercial practice
- ② Sample tests at low and high temperatures
- ③ -55°C to +105°C for AHE, ATO, ATW

**Part Numbering**

