

ATR28XXS SERIES

28V Input, Single Output

HYBRID - HIGH RELIABILITY DC-DC CONVERTER

Description

The ATR28XXS Series of DC-DC converters feature high power density and an extended temperature range for use in military and industrial applications. Designed to MIL-STD-704D input requirements, these devices have nominal 28VDC inputs with 3.3V, 5V, 12V and 15V single outputs to satisfy a wide range of requirements. The circuit design incorporates a pulse width modulated single forward topology operating in the feed-forward mode at a nominal switching frequency of 550KHz. Input to output isolation is achieved through the use of transformers in the forward and feedback circuits.

The advanced feedback design provides fast loop response for superior line and load transient characteristics and offers greater reliability and radiation tolerance than devices incorporating optical feedback circuits.

Three standard temperature grades are offered with screening options. Refer to Part Number section. These devices can be provided in a standard plug-in package for PC mounting or in a flanged package for more severe environments.

Manufactured in a facility fully qualified to MIL-PRF-38534, these converters are fabricated utilizing DLA Land and Maritime qualified processes. For available screening options, refer to device screening table in the data sheet. Variations in electrical, mechanical and screening can be accommodated.

Extensive computer simulation using complex modeling enables rapid design modification to be provided. Contact IR San Jose with specific requirements.

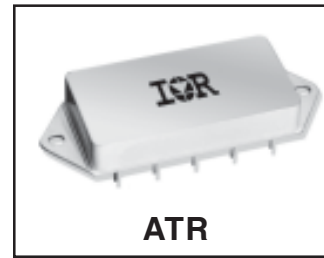

Features

- 16V to 40VDC Input Range (28VDC Nominal)
- 3.3V, 5V, 12V and 15V Outputs Available
- Indefinite Short Circuit and Overload Protection
- Up to 35W/in³ Power Density
- 30W Output Power Models
- Fast Loop Response for Superior Transient Characteristics
- Operating Temperature Range from -55°C to +125°C
- Popular Industry Standard Pin-Out
- Resistance Seam Welded Case for Superior Long Term Hermeticity
- Ceramic Feed-thru Pins
- External Synchronization
- Efficiencies up to 84%
- Shutdown from External Signal
- Military Screening
- Standard Microcircuit Drawings Available

Specifications

ATR2803R3S

Absolute Maximum Ratings	
Input voltage	-0.5V to +50VDC
Soldering temperature	300°C for 10 seconds
Operating case temperature	-55°C to +125°C
Storage case temperature	-65°C to +135°C

Table I. Electrical performance Characteristics

Test	Symbol	Conditions -55°C ≤ TC ≤ +125°C V _{IN} = 28VDC ±5%, C _L = 0 Unless otherwise specified	Group A Subgroups	Device Types	Limits		Units
					Min	Max	
Output voltage	V _{OUT}	I _{OUT} = 0	1 2,3	01	3.25 3.20	3.35 3.40	V
Output current ¹	I _{OUT}	V _{IN} = 16, 28, and 40 VDC	1,2,3	01		7500	mA
Output ripple voltage ²	V _{RIP}	V _{IN} = 16, 28, and 40 VDC B.W. = 20Hz to 2 MHz	1,2,3	01		60	mV p-p
Line regulation ³	VR _{LINE}	V _{IN} = 16, 28, and 40 VDC I _{OUT} = 0, 3000, and 6000mA	1 2,3	01		±20 ±30	mV
Load regulation ³	VR _{LOAD}	V _{IN} = 16,28, and 40 VDC I _{OUT} = 0, 3000, and 6000mA	1,2,3	01		±50	mV
Input current	I _{IN}	I _{OUT} = 0, inhibit (pin 2) Tied to input return (pin 10)	1,2,3	01		18	mA
Input ripple current ²	I _{RIP}	I _{OUT} = 0, inhibit (pin 2) = open I _{OUT} = 6000mA B.W. = 20Hz to 2 MHz	1,2,3	01		50 50	mA p-p
Efficiency	E _{FF}	I _{OUT} = 6000mA	1 2,3	01	74 70		%
Isolation	ISO	Input to output or any pin to case (except pin 8) at 500 VDC, TC = +25°C	1	01	100		MΩ
Capacitive load ^{4,5}	C _L	No effect on dc performance TC = +25°C	4	01		500	μF
Power dissipation load fault	P _D	Overload, TC = +25°C ⁶ Short Circuit	1 1,2,3	01		12 9.0	W
Switching frequency	F _S	I _{OUT} = 7500mA	4,5,6	01	500	600	KHz
Sync frequency range	F _{SYNC}	I _{OUT} = 7500mA	4,5,6	01	500	700	KHz
Output response to step transient load changes ⁷	VO _{TLOAD}	Load step 50% to/from 100% Load step 50% to/from 100%	4,5,6 4,5,6	01	-500 -500	+500 +500	mV pk
Recovery time step transient load changes ^{7,8}	TT _{LOAD}	Load step 50% to/from 100%	4 5,6 4 5,6	01		100 200 100 200	μs
Output response to transient step line changes ^{5,9}	VO _{TLINE}	Input step 16V to/from 40VDC, I _{OUT} = 7500mA	4,5,6	01		±500	mV pk

For Notes to Specifications, refer to page 3

Table I. Electrical performance Characteristics - continued

ATR2803R3S

	Symbol	Conditions -55°C ≤ TC ≤ +125°C V _{IN} = 28VDC ±5%, C _L = 0 Unless otherwise specified	Group A Subgroups	Device Types	Limits		Units
					Min	Max	
Recovery time transient step line changes ^{5, 8, 9}	T _{TLINE}	Input step 16V to/from 40VDC, I _{OUT} = 7500mA	4,5,6	01		10	ms
Turn on overshoot	V _{TonOS}	I _{OUT} = 10% to 100% of Load	4,5,6	01		350	mV pk
Turn on delay ¹⁰	T _{onD}	I _{OUT} = 0 and 7500mA	4,5,6	01		25	ms
Load fault recovery ^{5, 10}	T _{rLF}		4,5,6	01		25	ms

Notes to Specifications

- 1 Parameter guaranteed by line and load regulation tests.
- 2 Bandwidth guaranteed by design. Tested for 20KHz to 2.0MHz.
- 3 Output voltage measured at load with remote sense leads connected across load.
- 4 Capacitive load may be any value from 0 to the maximum limit without compromising dc performance. A capacitive load in excess of the maximum limit will not disturb loop stability but may interfere with the operation of the load fault detection circuitry, appearing as a short circuit during turn on.
- 5 Parameter shall be tested as part of design characterization and after design or process changes. There after parameters shall be guaranteed to the limits specified in table I.
- 6 An overload is that condition with a load in excess of the rated load but less than that necessary to trigger the short circuit protection and is the condition of maximum power dissipation.
- 7 Load step transition time between 2.0μs and 10μs.
- 8 Recovery time is measured from the initiation of the transient to where V_{OUT} has returned to within ±1.0% of V_{OUT} at 50% load.
- 9 Input step transition time between 2.0μs and 10μs.
- 10 Turn on delay time measurement is for either a step application of power at the input or the removal of a ground signal from the inhibit pin (pin 2) while power is applied to the input.

Specifications

ATR2805S

Absolute Maximum Ratings	
Input voltage	-0.5V to +50VDC
Soldering temperature	300°C for 10 seconds
Operating case temperature	-55°C to +125°C
Storage case temperature	-65°C to +135°C

Table II. Electrical performance Characteristics

Test	Symbol	Conditions -55°C ≤ TC ≤ +125°C V _{IN} = 28VDC ±5%, C _L = 0 Unless otherwise specified	Group A Subgroups	Device Types	Limits		Units
					Min	Max	
Output voltage	V _{OUT}	I _{OUT} = 0	1	01	4.95	5.05	V
			2,3		4.90	5.10	
Output current ¹	I _{OUT}	V _{IN} = 16, 28, and 40 VDC	1,2,3	01		6000	mA
Output ripple voltage ²	V _{RIP}	V _{IN} = 16, 28, and 40 VDC B.W. = 20Hz to 2 MHz	1,2,3	01		60	mV p-p
Line regulation ³	V _{RLINE}	V _{IN} = 16, 28, and 40 VDC I _{OUT} = 0, 3000, and 6000mA	1	01		±20	mV
			2,3			±30	
Load regulation ³	V _{RLOAD}	V _{IN} = 16,28, and 40 VDC I _{OUT} = 0, 3000, and 6000mA	1,2,3	01		±50	mV
Input current	I _{IN}	I _{OUT} = 0, inhibit (pin 2) Tied to input return (pin 10) I _{OUT} = 0, inhibit (pin 2) = open	1,2,3	01		18	mA
						50	
Input ripple current ²	I _{RIP}	I _{OUT} = 6000mA B.W. = 20Hz to 2 MHz	1,2,3	01		50	mA p-p
Efficiency	E _{FF}	I _{OUT} = 6000mA	1	01	76		%
			2,3		72		
Isolation	ISO	Input to output or any pin to case (except pin 8) at 500 VDC, TC = +25°C	1	01	100		MΩ
Capacitive load ^{4,5}	C _L	No effect on dc performance TC = +25°C	4	01		500	μF
Power dissipation load fault	P _D	Overload, TC = +25°C ⁶	1	01		12	W
		Short Circuit	1,2,3			9.0	
Switching frequency	F _S	I _{OUT} = 6000mA	4,5,6	01	500	600	KHz
Sync frequency range	F _{SYNC}	I _{OUT} = 6000mA	4,5,6	01	500	700	KHz
Output response to step transient load changes ⁷	V _{OLOAD}	3000mA to/from 6000mA	4,5,6	01	-500	+500	mV pk
		500mA to/from 3000mA	4,5,6		-500	+500	
Recovery time step transient load changes ^{7,8}	T _{TLOAD}	3000mA to/from 6000mA	4	01		100	μs
			5,6			200	
		500mA to/from 3000mA	4			100	
			5,6			200	
Output response to transient step line changes ^{5,9}	V _{OTLINE}	Input step 16V to/from 40VDC, I _{OUT} = 6000mA	4,5,6	01		±500	mV pk

For Notes to Specifications, refer to page 5

Table II. Electrical performance Characteristics - continued

ATR2805S

	Symbol	Conditions -55°C ≤ TC ≤ +125°C V _{IN} = 28VDC ±5%, C _L = 0 Unless otherwise specified	Group A Subgroups	Device Types	Limits		Units
					Min	Max	
Recovery time transient step line changes ^{5, 8, 9}	T _{TLINE}	Input step 16V to/from 40VDC, I _{OUT} = 6000mA	4,5,6	01		10	ms
Turn on overshoot	V _{TonOS}	I _{OUT} =0 and 6000mA	4,5,6	01		500	mV pk
Turn on delay ¹⁰	T _{onD}	I _{OUT} =0 and 6000mA	4,5,6	01		25	ms
Load fault recovery ^{5, 10}	T _{rLF}		4,5,6	01		25	ms

Notes to Specifications

- 1 Parameter guaranteed by line and load regulation tests.
- 2 Bandwidth guaranteed by design. Tested for 20KHz to 2.0MHz.
- 3 Output voltage measured at load with remote sense leads connected across load.
- 4 Capacitive load may be any value from 0 to the maximum limit without compromising dc performance. A capacitive load in excess of the maximum limit will not disturb loop stability but may interfere with the operation of the load fault detection circuitry, appearing as a short circuit during turn on.
- 5 Parameter shall be tested as part of design characterization and after design or process changes. There after parameters shall be guaranteed to the limits specified in table II.
- 6 An overload is that condition with a load in excess of the rated load but less than that necessary to trigger the short circuit protection and is the condition of maximum power dissipation.
- 7 Load step transition time between 2.0μs and 10μs.
- 8 Recovery time is measured from the initiation of the transient to where V_{OUT} has returned to within ±1.0% of V_{OUT} at 50% load.
- 9 Input step transition time between 2.0μs and 10μs.
- 10 Turn on delay time measurement is for either a step application of power at the input or the removal of a ground signal from the inhibit pin (pin 2) while power is applied to the input.

Specifications

ATR2812S

Absolute Maximum Ratings	
Input voltage	-0.5V to +50VDC
Soldering temperature	300°C for 10 seconds
Operating case temperature	-55°C to +125°C
Storage case temperature	-65°C to +135°C

Table III. Electrical performance Characteristics

Test	Symbol	Conditions -55°C ≤ TC ≤ +125°C V _{IN} = 28VDC ±5%, C _L = 0 Unless otherwise specified	Group A Subgroups	Device Types	Limits		Units
					Min	Max	
Output voltage	V _{OUT}	I _{OUT} = 0	1 2,3	01	11.88 11.70	12.12 12.30	V
Output current ¹	I _{OUT}	V _{IN} = 16, 28, and 40 VDC	1,2,3	01		2500	mA
Output ripple voltage ²	V _{RIP}	V _{IN} = 16, 28, and 40 VDC B.W. = 20Hz to 2 MHz	1,2,3	01		60	mVp-p
Line regulation ³	VR _{LINE}	V _{IN} = 16, 28, and 40 VDC I _{OUT} = 0, 1250, and 2500mA	1 2,3	01		±30 ±60	mV
Load regulation ³	VR _{LOAD}	V _{IN} = 16,28, and 40 VDC I _{OUT} = 0, 1250, and 2500mA	1 2,3	01		±60 ±120	mV
Input current	I _{IN}	I _{OUT} = 0, inhibit (pin 2) Tied to input return (pin 10) I _{OUT} = 0, inhibit (pin 2) = open	1,2,3 1 2,3	01		18 50 75	mA
Input ripple current ²	I _{RIP}	I _{OUT} = 2500mA B.W. = 20Hz to 2 MHz	1,2,3	01		50	mA _{p-p}
Efficiency	E _{FF}	I _{OUT} = 2500mA	1 2,3	01	80 75		%
Isolation	I _{SO}	Input to output or any pin To case (except pin 8) at 500 VDC, TC = +25°C	1	01	100		MΩ
Capacitive load ^{4,5}	C _L	No effect on dc performance TC = +25°C	4	01		500	μF
Power dissipation load fault	P _D	Overload, TC = +25°C ⁶ Short Circuit	1 1,2,3	01		12 9.0	W
Switching frequency	F _S	I _{OUT} = 2500mA	4,5,6	01	500	600	KHz
Sync frequency range	F _{SYNC}	I _{OUT} = 2500mA	4,5,6	01	500	700	KHz
Output response to step transient load changes ⁷	VO _{TLOAD}	1250mA to/from 2500mA 200mA to/from 1250mA	4,5,6 4,5,6	01	-800 -1000	+800 +1000	mV pk
Recovery time step transient load changes ^{7,8}	TT _{LOAD}	1250mA to/from 2500mA 200mA to/from 1250mA	4 5,6 4 5,6	01		100 200 100 200	μs
Output response to transient step line changes ^{5,9}	VO _{TLINE}	Input step 16V to/from 40VDC, I _{OUT} = 2500mA	4,5,6	01		±1200	mV pk

For Notes to Specifications, refer to page 7

Table III. Electrical performance Characteristics - continued

ATR2812S

Test	Symbol	Conditions -55°C ≤ TC ≤ +125°C V _{IN} = 28VDC ±5%, C _L = 0 Unless otherwise specified	Group A Subgroups	Device Types	Limits		Units
					Min	Max	
Recovery time transient step line changes ^{5, 8, 9}	TT _{LINE}	Input step 16V to/from 40VDC, I _{OUT} = 2500mA	4,5,6	01		10	ms
Turn on overshoot	V _{TonOS}	I _{OUT} = 0 and 2500mA	4,5,6	01		800	mV pk
Turn on delay ¹⁰	T _{onD}	I _{OUT} = 0 and 2500mA	4,5,6	01		25	ms
Load fault recovery ^{5, 10}	T _{rLF}		4,5,6	01		25	ms

Notes to Specifications

- 1 Parameter guaranteed by line and load regulation tests.
- 2 Bandwidth guaranteed by design. Tested for 20KHz to 2.0MHz.
- 3 Output voltage measured at load with remote sense leads connected across load.
- 4 Capacitive load may be any value from 0 to the maximum limit without compromising dc performance. A capacitive load in excess of the maximum limit will not disturb loop stability but may interfere with the operation of the load fault detection circuitry, appearing as a short circuit during turn on.
- 5 Parameter shall be tested as part of design characterization and after design or process changes. There after parameters shall be guaranteed to the limits specified in table III.
- 6 An overload is that condition with a load in excess of the rated load but less than that necessary to trigger the short circuit protection and is the condition of maximum power dissipation.
- 7 Load step transition time between 2.0μs and 10μs.
- 8 Recovery time is measured from the initiation of the transient to where V_{OUT} has returned to within ±1.0% of V_{OUT} at 50% load.
- 9 Input step transition time between 2.0μs and 10μs.
- 10 Turn on delay time measurement is for either a step application of power at the input or the removal of a ground signal from the inhibit pin (pin 2) while power is applied to the input.

Specifications

ATR2815S

Absolute Maximum Ratings	
Input voltage	-0.5V to +50VDC
Soldering temperature	300°C for 10 seconds
Operating case temperature	-55°C to +125°C
Storage case temperature	-65°C to +135°C

Table IV. Electrical performance Characteristics

Test	Symbol	Conditions -55°C ≤ TC ≤ +125°C V _{IN} = 28VDC ±5%, C _L = 0 Unless otherwise specified	Group A Subgroups	Device Types	Limits		Units
					Min	Max	
Output voltage	V _{OUT}	I _{OUT} = 0	1 2,3	01	14.85 14.60	15.15 15.40	V
Output current ¹	I _{OUT}	V _{IN} = 16, 28, and 40 VDC each output.	1,2,3	01		2000	mA
Output ripple voltage ³	V _{RIP}	V _{IN} = 16, 28, and 40 VDC B.W. = 20Hz to 2 MHz	1,2,3	01		±75	mVp-p
Line regulation ³	VR _{LINE}	V _{IN} = 16, 28, and 40 VDC I _{OUT} = 0, 1250, and 2500mA	1 2,3	01		±35 ±75	mV
Load regulation ³	VR _{LOAD}	V _{IN} = 16,28, and 40 VDC I _{OUT} = 0, 1250, and 2500mA	1 2,3	01		±75 ±150	mV
Input current	I _{IN}	I _{OUT} = 0, inhibit (pin 2) Tied to input return (pin 10) I _{OUT} = 0, Inhibit (pin 2) = open	1,2,3 1 2,3	01		18 75 100	mA
Input ripple current ²	I _{RIP}	I _{OUT} = 2500mA B.W. = 20Hz to 2 MHz	1,2,3	01		50	mAp-p
Efficiency ⁴	E _{FF}	I _{OUT} = 2500mA	1 2,3	01	79 75		%
Isolation	ISO	Input to output or any pin to case (except pin 7) at 500 VDC, TC = +25°C	1	01	100		MΩ
Capacitive load ^{4, 5}	C _L	No effect on dc performance, TC = +25°C. Total for both outputs	4	01		500	μF
Power dissipation load fault	P _D	Overload, TC = +25°C ⁶ Short Circuit	1 1,2,3	01		12 9.0	W
Switching frequency ⁴	F _S	I _{OUT} = 2500mA	4,5,6	01	500	600	KHz
Sync frequency range	F _{SYNC}	I _{OUT} = 2500mA	4,5,6	01	500	700	KHz
Output response to step transient load changes ⁷	VO _{TLOAD}	1000mA to/from 2000mA 167mA to/from 1000mA	4,5,6 4,5,6	01	-1000 -1000	+1000 +1000	mVp-k
Recovery time step transient load changes ^{7, 8}	TT _{LOAD}	1000mA to/from 2000mA 167mA to/from 1000mA	4 5,6 4 5,6	01		100 200 100 200	μs
Output response to transient step line changes ^{5, 9}	VO _{TLINE}	Input step 16V to/from 40VDC, I _{OUT} = 2000mA	4,5,6	01		±1500	mVpk

For Notes to Specifications, refer to page 9

Table IV. Electrical performance Characteristics - continued

ATR2815S

Test	Symbol	Conditions -55°C ≤ TC ≤ +125°C V _{IN} = 28VDC ±5%, C _L = 0 Unless otherwise specified	Group A Subgroups	Device Types	Limits		Units
					Min	Max	
Recovery time transient step line changes ^{5, 8, 9}	T _{TLINE}	Input step 16V to/from 40VDC, I _{OUT} = 2500mA	4,5,6	01		10	ms
Turn on overshoot	V _{TonOS}	I _{OUT} = 0 and 2000mA	4,5,6	01		1000	mVpk
Turn on delay ¹⁰	T _{onD}	I _{OUT} = 0 and 2000mA	4,5,6	01		25	ms
Load fault recovery ^{5, 10}	T _{LF}		4,5,6	01		25	ms

Notes to Specifications

- 1 Parameter guaranteed by line and load regulation tests.
- 2 Bandwidth guaranteed by design. Tested for 20KHz to 2.0MHz.
- 3 Output voltage measured at load with remote sense leads connected across load.
- 4 Capacitive load may be any value from 0 to the maximum limit without compromising dc performance. A capacitive load in excess of the maximum limit will not disturb loop stability but may interfere with the operation of the load fault detection circuitry, appearing as a short circuit during turn on.
- 5 Parameter shall be tested as part of design characterization and after design or process changes. There after parameters shall be guaranteed to the limits specified in table IV.
- 6 An overload is that condition with a load in excess of the rated load but less than that necessary to trigger the short circuit protection and is condition of maximum power dissipation.
- 7 Load step transition time between 2.0μs and 10μs.
- 8 Recovery time is measured from the initiation of the transient to where V_{OUT} has returned to within ±1.0% of V_{OUT} at 50% load.
- 9 Input step transition time between 2.0μs and 10μs.
- 10 Turn on delay time measurement is for either a step application of power at the input or the removal of a ground signal from the inhibit pin (pin2) while power is applied to the input.

Block Diagram

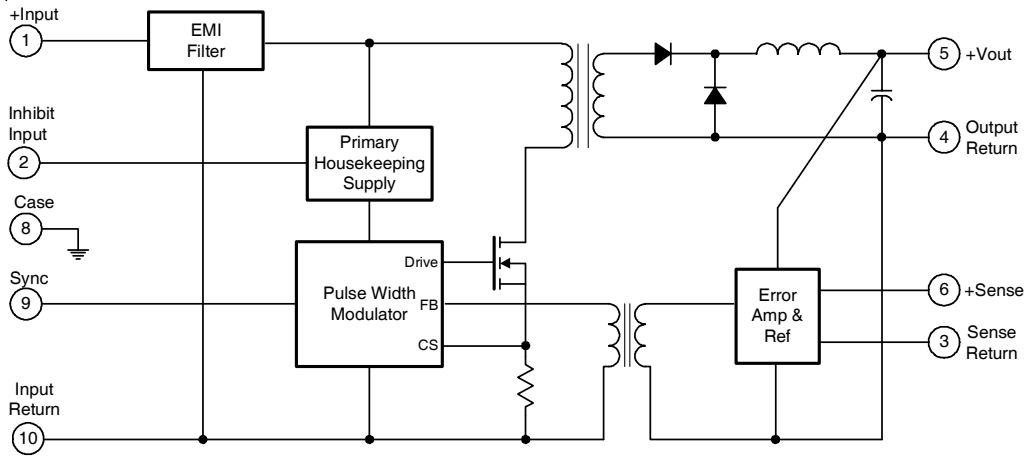

Application Information

Inhibit Function

Connecting the inhibit input (Pin 2) to input common (Pin 10) will cause the converter to shut down. It is recommended that the inhibit pin be driven by an open collector device capable of sinking at least 400µA of current. The open circuit voltage of the inhibit input is 11.5 ±1.0VDC.

EMI Filter

An Optional EMI filter (AFC461) is available that will reduce the input ripple current to levels below the limits imposed by MIL-STD-461B CEO3.

Output Voltage Adjustment

The output voltage of the ATR2805S converter can be adjusted upward by connecting an appropriate resistor value between the Positive Output (Pin 5) and the Positive Sense (Pin 6) as shown in Table 1 below.

Resistance Pin 5 to 6 (Ω)	Output Voltage Increase (V)
109	0.1
240	0.2
400	0.3
600	0.4
857	0.5
1200	0.6

Table1 Output adjustment resistor values for ATR2805S

Device Synchronization

Whenever multiple DC/DC converters are utilized in a single system, significant low frequency noise may be generated due to slight difference in the switching frequencies of the converters. Because of the low frequency nature of this noise (typically less than 10KHz), it is difficult to filter out and may interfere with proper operation of sensitive systems. International Rectifier permits synchronization of multiple ATR28XX converters to match switching frequency of the converter to the frequency of the system clock, thus eliminating this type of noise.

Thermal Management

Assuming that there is no forced air flow, the package temperature rise above ambient (ΔT) may be calculated using the following expression:

$$\Delta T = 80 A^{-0.7} P^{0.85} (\text{°C})$$

where A = the effective surface area in square inches (Including heat sink if used), P_d = power dissipation in watts.

The total surface area of the ATR package is 7.34 square inches. If a worst case full load efficiency of 76% is assumed, then the case temperature rise of an ATR2805S can be calculated as follows:

$$P = P_{out} \left[\frac{1}{Eff} - 1 \right] = 30 \left[\frac{1}{0.76} - 1 \right] = 9.5W$$

$$\Delta T = 80 (7.34)^{-0.7} (9.5)^{0.85} = 134\text{°C}$$

Hence, if T_{AMBIENT} = +25°C, the DC/DC converter case temperature will be approximately 159°C if no heat sink or air flow is provided.

To calculate the heat sink area required to maintain a specific case temperature rise, the above equation may be manipulated as follows:

$$A_{HEATSINK} = \left[\frac{\Delta T}{80 P_d^{0.85}} \right]^{-1.43} - A_{PKG}$$

As an example, if a maximum case temperature rise of 50°C above ambient is required, then the required effective heat sink area is:

$$A_{HEATSINK} = \left[\frac{50}{80 (9.5)^{0.85}} \right]^{-1.43} - 7.34 = 22.9\text{in}^2$$

Mechanical Outlines

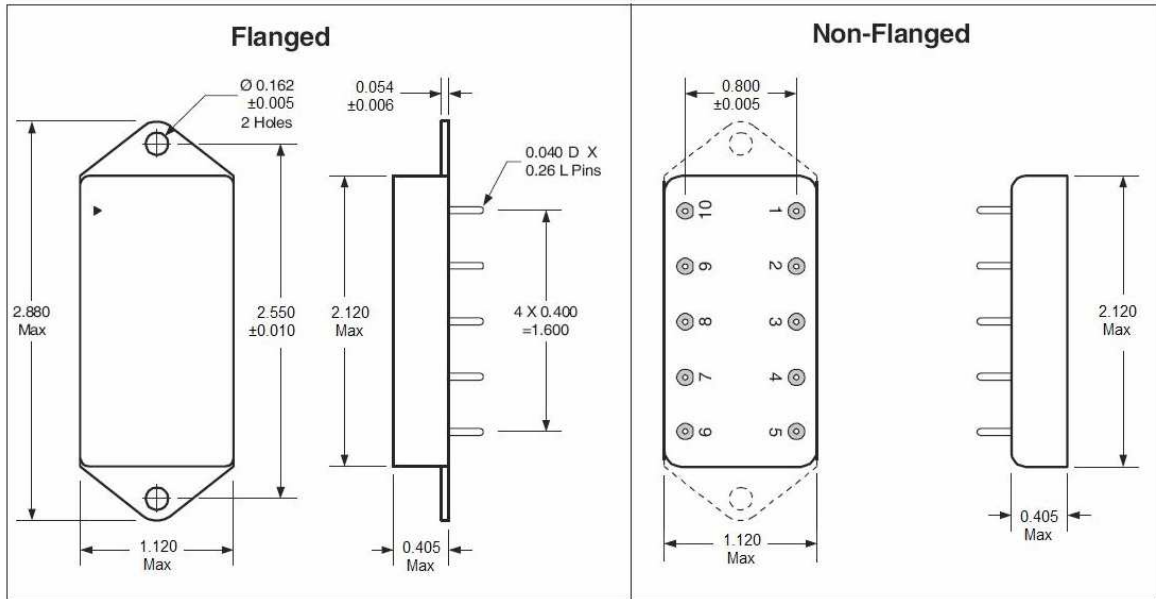

Pin Designation

Pin #	Designation
1	+ Input
2	Inhibit Input
3	Sense Return*
4	Output Return
5	+ Output
6	+ Sense*
7	NC
8	Case Ground
9	Sync.
10	Input Return

* If neither remote sense nor voltage trim is used, connect Pin 3 to 4 and 5 to 6 or output voltage will increase by 1.2V.

Standard Microcircuit Drawing Equivalence Table

Standard Microcircuit Drawing Number	Vendor Cage Code	IR Standard Part Number
5962-94624	52467	ATR2805S
5962-94625	52467	ATR2812S

Device Screening

Requirement	MIL-STD-883 Method	No Suffix	ES ②	HB	CH
Temperature Range	—	-20°C to +85°C	-55°C to +125°C ③	-55°C to +125°C	-55°C to +125°C
Element Evaluation	MIL-PRF-38534	N/A	N/A	N/A	Class H
Non-Destructive Bond Pull	2023	N/A	N/A	N/A	N/A
Internal Visual	2017	①	Yes	Yes	Yes
Temperature Cycle	1010	N/A	Cond B	Cond C	Cond C
Constant Acceleration	2001, Y1 Axis	N/A	500 Gs	3000 Gs	3000 Gs
PIND	2020	N/A	N/A	N/A	N/A
Burn-In	1015	N/A	48 hrs@hi temp	160 hrs@125°C	160 hrs@125°C
Final Electrical (Group A)	MIL-PRF-38534 & Specification	25°C	25°C ②	-55°C, +25°C, +125°C	-55°C, +25°C, +125°C
PDA	MIL-PRF-38534	N/A	N/A	N/A	10%
Seal, Fine and Gross	1014	Cond A	Cond A, C	Cond A, C	Cond A, C
Radiographic	2012	N/A	N/A	N/A	N/A
External Visual	2009	①	Yes	Yes	Yes

Notes:

- ① Best commercial practice
- ② Sample tests at low and high temperatures
- ③ -55°C to +105°C for AHE, ATO, ATW

Part Numbering

