

ATR28XXD SERIES

28V Input, Dual Output

HYBRID - HIGH RELIABILITY DC-DC CONVERTER

Description

The ATR28XXD Series of DC-DC converters feature high power density and an extended temperature range for use in military and industrial applications. Designed to MIL-STD-704D input requirements, these devices have nominal 28VDC inputs with $\pm 12V$ and $\pm 15V$ dual outputs to satisfy a wide range of requirements. The circuit design incorporates a pulse width modulated single forward topology operating in the feed-forward mode at a nominal switching frequency of 550KHz. Input to output isolation is achieved through the use of transformers in the forward and feedback circuits.

The advanced feedback design provides fast loop response for superior line and load transient characteristics and offers greater reliability and radiation tolerance than devices incorporating optical feedback circuits.

Three standard temperature grades are offered with screening options. Refer to Part Number section. They can be provided in a standard plug-in package for PC mounting or in a flanged package for more severe environments.

Manufactured in a facility fully qualified to MIL-PRF-38534, these converters are fabricated utilizing DLA and Land Maritime qualified processes. For available screening options, refer to device screening table in the data sheet. Variations in electrical, mechanical and screening can be accommodated.

Extensive computer simulation using complex modeling enables rapid design modification to be provided. Contact IR San Jose with specific requirements.

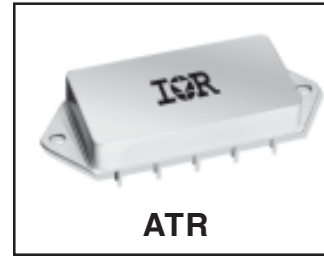

Features

- 16V to 40VDC Input Range (28VDC Nominal)
- $\pm 12V$ and $\pm 15V$ Outputs Available
- Indefinite Short Circuit and Overload Protection
- 35W/in³ Power Density
- 30W Output Power
- Fast Loop Response for Superior Transient Characteristics
- Operating Temperature Range from -55°C to +125°C
- Popular Industry Standard Pin-Out
- Resistance Seam Welded Case for Superior Long Term Hermeticity
- Ceramic Feed-thru Pins
- External Synchronization
- High Efficiency
- Shutdown from External Signal
- Military Screening
- Standard Microcircuit Drawings Available

Specifications

T_{CASE} = -55°C to +85°C, V_{IN} = +28V ± 5% unless otherwise specified

Absolute Maximum Ratings		
Input voltage	-0.5V to +50VDC	
Power Output	Internally limited, 36W typical	
Soldering temperature	300°C for 10 seconds	
Temperature Range ¹	Recommended Operating temperature	-55°C to +85°C
	Maximum Operating temperature	-55°C to +115°C
	Storage case temperature	-65°C to +135°C

PARAMETER	Condition -55°C ≤ TC ≤ +85°C, V _{IN} = 28 V _{DC} ±5%, CL=0, unless otherwise specified	ATR2812D			ATR2815D			Units
		Min	Typ	Max	Min	Typ	Max	
STATIC CHARACTERISTICS								
OUTPUT	V _{IN} = 16 to 40 V _{DC}							
Voltage	I _{OUT} = 0 to Full Load	±11.76	±12	±12.24	±14.70	±15	±15.30	V _{DC}
Current ⁵		0.0		±1.25	0.0		±1.0	A _{DC}
Ripple	Full Load, 20KHz to 2MHz		40	85		40	85	mV p-p
Accuracy	T _{CASE} = 25°C, Full Load	±11.88	±12	±12.12	±14.85	±15.00	±15.15	V _{DC}
Power ⁶		30			30			W
REGULATION								
Line	V _{IN} = 16 to 40 V _{DC}			75			75	mV
Load	I _{OUT} = 0 to Full Load			120			150	mV
CROSS REGULATION ⁶	V _{IN} = 16, 28, and 40 V _{DC}			±5			±5	%
INPUT								
Voltage Range	No Load, pin 2 = open	16	28	40	16	28	40	V _{DC}
Current	Inhibited, pin 2 tied to pin 10			75			75	mA _{DC}
Ripple Current	Full Load		25	50		25	50	mA p-p
EFFICIENCY	Full Load T _C = +25°C		82			82		%
ISOLATION	Input to output @ 500 V _{DC}	100			100			MΩ
CAPACITIVE LOAD	No effect on performance T _C = +25°C (total for both outputs)			100			100	μF
Load Fault Power Dissipation	Short Circuit Overload, T _C = +25°C			9.0 14			9.0 14	W W
Switching Frequency	I _{OUT} = Full Load	500		600	500		600	KHz
SYNC Frequency Range ⁷		500		700	500		700	KHz
DYNAMIC CHARACTERISTICS								
Step Load Changes								
Output Transient	50% Load to 100% Load No Load to 50% Load		±100 ±250			±100 ±250		mVpk mVpk
Recovery ²	50% Load to 100% Load No Load to 50% Load 50% Load to No Load		25 500 3.0			25 500 3.0		μs μs ms
Step Line Changes								
Output Transient	Input step 16 to 40 V _{DC} Input step 40 to 16 V _{DC}		±180 -600			±180 -600		mVpk mVpk
Recovery ²	Input step 16 to 40 V _{DC} Input step 40 to 16 V _{DC}		5.0 5.0			5.0 5.0		ms ms
TURN-ON								
Overshoot	V _{IN} = 16 to 40 V _{DC}		0.0	600		0.0	600	mVpk
Delay ³	I _{OUT} = 0 and Full Load		14	25		14	25	ms
Load Fault Recovery	V _{IN} = 16 to 40 V _{DC}		14	25		14	25	ms

Notes to Specifications

- Above +85°C case temperature, derate output power linearly to 0 at +115°C case.
- Recovery time is measured from the initiation of the input transient to where V_{OUT} has returned to within ±1% of V_{OUT} at 50% load.
- Turn-on delay time measurement is for either an application of power at the input or a signal at the inhibit pin.
- Load current split equally between +V_{OUT} and -V_{OUT}.
- Up to 90% of Full Power is available from either output provided. The total power output does not exceed 30W.
- 3W load on output under test, 3W to 27W on other output.
- Sync. Input signal: V_{IL} = -0.5V Min, 0.8V Max and V_{IN} = 2.5V Min, 11.5V Max for 10% to 90% duty cycle.

Specifications

$T_{CASE} = -55^{\circ}\text{C}$ to $+125^{\circ}\text{C}$, $V_{IN} = +28\text{V} \pm 5\%$ unless otherwise specified

Absolute Maximum Ratings		
Input voltage	-0.5V to +50VDC	
Power Output	Internally limited, 36W typical	
Soldering temperature	300°C for 10 seconds	
Temperature Range ¹	Recommended Operating temperature	-55°C to +125°C
	Maximum Operating temperature	-55°C to +135°C
	Storage case temperature	-65°C to +135°C

PARAMETER	Condition $-55^{\circ}\text{C} \leq T_C \leq +125^{\circ}\text{C}$, $V_{IN} = 28$ $V_{DC} \pm 5\%$, $CL=0$, unless otherwise specified	ATR2812D/ES			ATR2815D/ES			Units
		Min	Typ	Max	Min	Typ	Max	
STATIC CHARACTERISTICS								
OUTPUT	$V_{IN} = 16$ to $40 V_{DC}$							
Voltage	$I_{OUT} = 0$ to Full Load	± 11.76	± 12	± 12.24	± 14.70	± 15	± 15	V_{DC}
Current ⁵		0.0		± 1.25	0.0		± 1.0	A_{DC}
Ripple	Full Load, 20KHz to 2MHz		40	85		40	85	mV p-p
Accuracy	$T_{CASE} = 25^{\circ}\text{C}$, Full Load	± 11.88	± 12.00	± 12.12	± 14.85	± 15.00	± 15.15	V_{DC}
Power ¹		30			30			W
REGULATION								
Line	$V_{IN} = 16$ to $40 V_{DC}$			75			75	mV
Load	$I_{OUT} = 0$ to Full Load			120			150	mV
CROSS REGULATION ⁶	$V_{IN} = 16, 28, \text{ and } 40 V_{DC}$			± 5			± 5	%
INPUT								
Voltage Range	No Load, pin 2 = open	16	28	40	16	28	40	V_{DC}
Current	Inhibited, pin 2 tied to pin 10			75			75	mA_{DC}
Ripple Current	Full Load		25	50		25	50	mA_{DC}
EFFICIENCY	Full Load $T_C = +25^{\circ}\text{C}$	80	82		79	82		%
ISOLATION	Input to output @ $500 V_{DC}$	100			100			MΩ
CAPACITIVE LOAD	No effect on performance $T_C = +25^{\circ}\text{C}$ (total for both outputs)			100			100	μF
Load Fault Power Dissipation	Short Circuit Overload, $T_C = +25^{\circ}\text{C}$			9.0 14			9.0 14	W W
Switching Frequency	$I_{OUT} = \text{Full Load}$	500		600	500		600	KHz
SYNC Frequency Range ⁷		500		700	500		700	KHz
DYNAMIC CHARACTERISTICS								
Step Load Changes								
Output	50% Load to 100% Load		± 100			± 100		mVpk
Transient	No Load to 50% Load		± 250			± 250		mVpk
Recovery ²	50% Load to 100% Load		25			25		μs
	No Load to 50% Load		500			500		μs
	50% Load to No Load		3.0			3.0		ms
Step Line Changes								
Output	Input step 16 to $40 V_{DC}$		± 180			± 180		mVpk
Transient	Input step 40 to $16 V_{DC}$		-600			-600		mVpk
Recovery ²	Input step 16 to $40 V_{DC}$		5.0			5.0		ms
	Input step 40 to $16 V_{DC}$		5.0			5.0		ms
TURN-ON								
Overshoot	$V_{IN} = 16$ to $40 V_{DC}$		0.0	600		0.0	600	mVpk
Delay ³	$I_{OUT} = 0$ to Full Load		14	25		14	25	ms
Load Fault Recovery	$V_{IN} = 16$ to $40 V_{DC}$		14	25		14	25	ms

Notes to Specifications

- Above $+125^{\circ}\text{C}$ case temperature, derate output power linearly to 0 at $+135^{\circ}\text{C}$ case.
- Recovery time is measured from the initiation of the input transient to where V_{OUT} has returned to within $\pm 1\%$ of V_{OUT} at 50% load.
- Turn-on delay time measurement is for either an application of power at the input or a signal at the inhibit pin.
- Load current split equally between $+V_{OUT}$ and $-V_{OUT}$.
- Up to 90% of Full Power is available from either output provided. The total power output does not exceed 30W.
- 3W load on output under test, 3W to 27W on other output.
- Sync. Input signal: $V_{IL} = -0.5\text{V}$ Min, 0.8V Max and $V_{IN} = 2.5\text{V}$ Min, 11.5V Max for 10% to 90% duty cycle.

Specifications

T_{CASE} = -55°C to +125°C, V_{IN} = +28V ± 5% unless otherwise specified

Absolute Maximum Ratings		
Input voltage	-0.5V to +50VDC	
Power Output	Internally limited, 36W typical	
Soldering temperature	300°C for 10 seconds	
Temperature Range ¹	Recommended Operating temperature	-55°C to +125°C
	Maximum Operating temperature	-55°C to +135°C
	Storage case temperature	-65°C to +135°C

PARAMETER	Condition -55°C ≤ TC ≤ +125°C, V _{IN} = 28 V _{DC} ±5%, CL=0, unless otherwise specified	ATR2812D/HB			ATR2815D/HB			Units
		Min	Typ	Max	Min	Typ	Max	
STATIC CHARACTERISTICS								
OUTPUT Voltage	V _{IN} = 16 to 40 V _{DC} I _{OUT} = 0 to Full Load	±11.76	±12.00	±12.24	±14.70	±15	±15.30	V _{DC}
Current ⁵		0.0		±1.25	0.0		±1.0	A _{DC}
Ripple	Full Load, 20KHz to 2MHz		40	85		40	85	mV p-p
Accuracy	T _{CASE} = 25°C, Full Load	±11.88	±12.00	±12.12	±14.85	±15.00	±15.15	V _{DC}
Power ¹		30			30			W
REGULATION Line ⁴	V _{IN} = 16 to 40 V _{DC} I _{OUT} = 0 to Full Load			75			75	mV
Load ⁴				120			150	mV
CROSS REGULATION ⁶	V _{IN} = 16, 28, and 40 V _{DC}			±5			±5	%
INPUT Voltage Range		16	28	40	16	28	40	V _{DC}
Current	No Load, pin 2 = open Inhibited, pin 2 tied to pin 10			75		18	75	mA _{DC}
Ripple Current	Full Load		25	50		25	50	mA p-p
EFFICIENCY	Full Load T _C = +25°C	80	82		79	82		%
ISOLATION	Input to output @ 500 V _{DC}	100			100			MΩ
CAPACITIVE LOAD	No effect on performance T _C = +25°C (total for both outputs)			100			100	μF
Load Fault Power Dissipation	Short Circuit Overload, T _C = +25°C			9.0			9.0	W
Switching Frequency	I _{OUT} = Full Load	500		600	500		600	KHz
SYNC Frequency Range ⁷		500		700	500		700	KHz
DYNAMIC CHARACTERISTICS								
Step Load Changes								
Output ⁴	50% Load to 100% Load		±100	±450		±100	±450	mVpk
Transient	No Load to 50% Load		±250	±760		±250	±750	mVpk
Recovery ²	50% Load to 100% Load		25	70		25	70	μs
	No Load to 50% Load		500	1500		500	1500	μs
	50% Load to No Load		3.0	5.0		3.0	5.0	ms
Step Line Changes								
Output	Input step 16 to 40 V _{DC}		±180	1200		±180	1500	mVpk
Transient	Input step 40 to 16 V _{DC}		-600	-1500		-600	-1500	mVpk
Recovery ²	Input step 16 to 40 V _{DC}		5.0	10		5.0	10	ms
	Input step 40 to 16 V _{DC}		5.0	10		5.0	10	ms
TURN-ON								
Overshoot	V _{IN} = 16 to 40 V _{DC}		0.0	600		0.0	600	mVpk
Delay ³	I _{OUT} = 0 to Full Load		14	25		14	25	ms
Load Fault Recovery	V _{IN} = 16 to 40 V _{DC}		14	25		14	25	ms

Notes to Specifications

- Above +125°C case temperature, derate output power linearly to 0 at +135°C case.
- Recovery time is measured from the initiation of the input transient to where V_{OUT} has returned to within ±1% of V_{OUT} at 50% load.
- Turn-on delay time measurement is for either an application of power at the input or a signal at the inhibit pin.
- Load current split equally between +V_{OUT} and -V_{OUT}.
- Up to 90% of Full Power is available from either output provided. The total power output does not exceed 30W.
- 3W load on output under test, 3W to 27W on other output.
- Sync. Input signal: V_{IL} = -0.5V Min, 0.8V Max and V_{IN} = 2.5V Min, 11.5V Max for 10% to 90% duty cycle.

Specifications

$T_{CASE} = -55^{\circ}\text{C}$ to $+125^{\circ}\text{C}$, $V_{IN} = +28\text{V} \pm 5\%$ unless otherwise specified

Absolute Maximum Ratings		
Input voltage	-0.5V to +50VDC	
Power Output	Internally limited, 36W typical	
Soldering temperature	300°C for 10 seconds	
Temperature Range ¹	Recommended Operating temperature	-55°C to +125°C
	Maximum Operating temperature	-55°C to +135°C
	Storage case temperature	-65°C to +135°C

PARAMETER	Condition -55°C ≤ TC ≤ +125°C, VIN = 28 VDC ±5%, CL=0, unless otherwise specified	ATR2812D/CH			ATR2815D/CH			Units
		Min	Typ	Max	Min	Typ	Max	
STATIC CHARACTERISTICS								
OUTPUT								
Voltage	VIN = 16 to 40 VDC	±11.76	±12.00	±12.24	±14.70	±15	±15.30	VDC
Current ⁵	IOUT = 0 to Full Load	0.0	40	±1.25	0.0	40	±1.0	A _{DC}
Ripple	Full Load, 20KHz to 2MHz			85			85	mV p-p
Accuracy	T _{CASE} = 25°C, Full Load	±11.88	±12.00	±12.12	±14.85	±15.00	±15.15	VDC
Power ¹		30			30			W
REGULATION								
Line ⁴	VIN = 16 to 40 VDC			75			75	mV
Load ⁴	IOUT = 0 to Full Load			120			150	mV
CROSS REGULATION ⁶	VIN = 16, 28, and 40 VDC			±5			±5	%
INPUT								
Voltage Range		16	28	40	16	28	40	VDC
Current	No Load, pin 2 = open			75			75	mA _{DC}
	Inhibited, pin 2 tied to pin 10			18			18	mA _{DC}
	Full Load		25	50		25	50	mA p-p
Ripple Current								mA p-p
EFFICIENCY	Full Load TC = +25°C	80	82		79	82		%
ISOLATION	Input to output @500 VDC	100			100			MΩ
CAPACITIVE LOAD	No effect on performance TC = +25°C (total for both outputs)			100			100	μF
Load Fault Power Dissipation	Short Circuit Overload, TC = +25°C			9.0 14			9.0 14	W W
Switching Frequency	IOUT = Full Load	500		600	500		600	KHz
SYNC Frequency Range ⁷		500		700	500		700	KHz
DYNAMIC CHARACTERISTICS								
Step Load Changes								
Output ⁴	50% Load to 100% Load		±100	±450		±100	±450	mVpk
Transient	No Load to 50% Load		±250	±760		±250	±750	mVpk
Recovery ²	50% Load to 100% Load		25	70		25	70	μs
	No Load to 50% Load		500	1500		500	1500	μs
	50% Load to No Load		3.0	5.0		3.0	5.0	ms
Step Line Changes								
Output	Input step 16 to 40 VDC		±180	1200		±180	1500	mVpk
Transient	Input step 40 to 16 VDC		-600	-1500		-600	-1500	mVpk
Recovery ²	Input step 16 to 40 VDC		5.0	10		5.0	10	ms
	Input step 40 to 16 VDC		5.0	10		5.0	10	ms
TURN-ON								
Overshoot	VIN = 16 to 40 VDC		0.0	600		0.0	600	mVpk
Delay ³	IOUT = 0 to Full Load		14	25		14	25	ms
Load Fault Recovery	VIN = 16 to 40 VDC		14	25		14	25	ms

Notes to Specifications

- Above +125°C case temperature, derate output power linearly to 0 at +135°C case.
- Recovery time is measured from the initiation of the input transient to where V_{OUT} has returned to within ±1% of V_{OUT} at 50% load.
- Turn-on delay time measurement is for either an application of power at the input or a signal at the inhibit pin.
- Load current split equally between +V_{OUT} and -V_{OUT}.
- Up to 90% of Full Power is available from either output provided. The total power output does not exceed 30W.
- 3W load on output under test, 3W to 27W on other output.
- Sync. Input signal: V_L = -0.5V Min, 0.8V Max and V_{IN} = 2.5V Min, 11.5V Max for 10% to 90% duty cycle.

Block Diagram

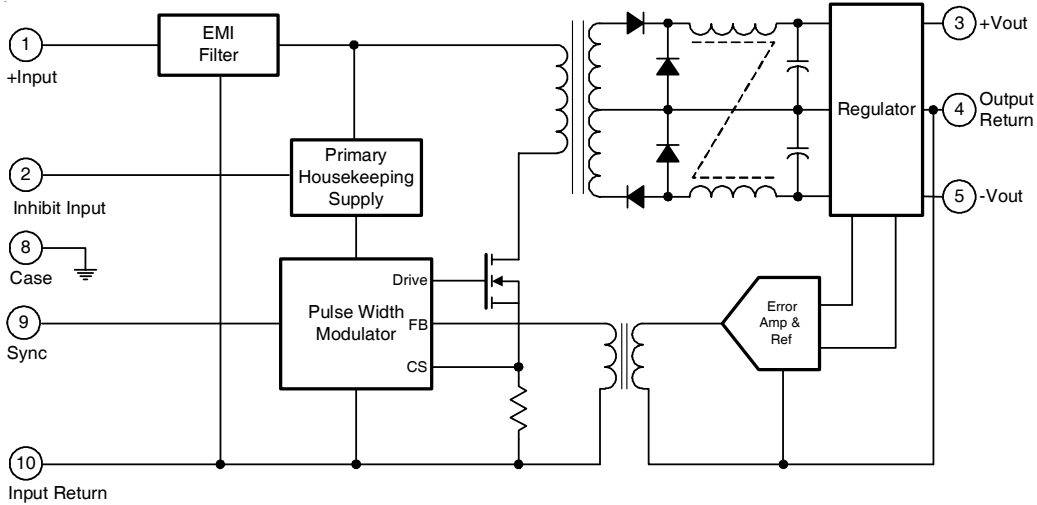

Application Information

Inhibit Function

Connecting the inhibit input (Pin 2) to input common (Pin 10) will cause the converter to shut down. It is recommended that the inhibit pin be driven by an open collector device capable of sinking at least 400µA of current. The open circuit voltage of the inhibit input is 11.5 ±1.0VDC.

EMI Filter

An EMI filter (AFC461), available as an option, will reduce the input ripple current to levels below the limits imposed by MIL-STD-461B CEO3.

Device Synchronization

Whenever multiple DC/DC converters are utilized in a single system, significant low frequency noise may be generated due to slight difference in the switching frequencies of the converters (beat frequency noise). Because of the low frequency nature of this noise (typically less than 10KHz), it is difficult to filter out and may interfere with proper operation of sensitive systems (communications, radar or telemetry). The International Rectifier ATR28XX converters provide a synchronizing input permitting synchronization of multiple converters to the frequency of the users system clock, thereby minimizing this type of noise.

Thermal Management

Assuming that there is no forced air flow, the package temperature rise above ambient (ΔT) may be calculated using the following expression:

$$\Delta T = 80 A^{-0.7} P_d^{0.85} \text{ (}^\circ\text{C)} \quad (1)$$

where A = the effective surface area in square inches (including heat sink if used), P_d = power dissipation in watts.

The total surface area of the ATR standard package is 7.34 square inches. If a worse case full load efficiency of 78% is assumed, then the case temperature rise can be calculated as follows:

$$P_d = P_{OUT} \left[\frac{1}{Eff} - 1 \right] = 30 \left[\frac{1}{0.78} - 1 \right] = 8.5W$$

and $\Delta T = 80 (7.34)^{-0.7} (8.5)^{0.85} = 122^\circ\text{C}$

Hence, if T_{AMBIENT} = +25°C, the DC/DC converter case temperature will be approximately 147°C if no heat sink or air flow is provided.

To calculate the heat sink area required to maintain a specific case temperature rise, equation (1) may be manipulated as follows:

$$A_{HEATSINK} = \left[\frac{\Delta T}{80 P_d^{0.85}} \right]^{-1.43} - A_{PKG}$$

As an example, if it is desired to limit the case temperature rise to a maximum of 50°C above ambient, the required effective heat sink area is:

$$A_{HEATSINK} = \left[\frac{50}{80(8.5)^{0.85}} \right]^{-1.43} - 7.34 = 19.1in^2$$

Mechanical Outlines

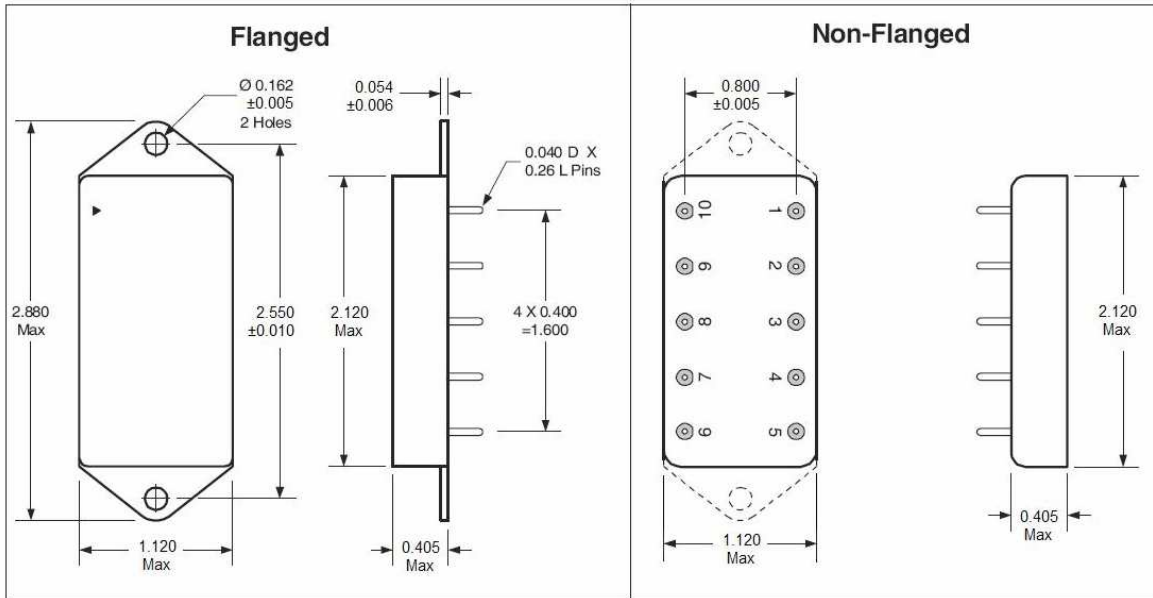

Pin Designation

Pin #	Designation
1	+ Input
2	Inhibit Input
3	+ Output
4	Output Return
5	- Output
6	NC
7	NC
8	Case Ground
9	Sync.
10	Input Return

Standard Microcircuit Drawing Equivalence Table

Standard Microcircuit Drawing Number	Vendor Cage Code	IR Standard Part Number
5962-94627	52467	ATR2812D
5962-94628	52467	ATR2815D

Device Screening

Requirement	MIL-STD-883 Method	No Suffix	ES ②	HB	CH
Temperature Range	—	-20°C to +85°C	-55°C to +125°C ③	-55°C to +125°C	-55°C to +125°C
Element Evaluation	MIL-PRF-38534	N/A	N/A	N/A	Class H
Non-Destructive Bond Pull	2023	N/A	N/A	N/A	N/A
Internal Visual	2017	①	Yes	Yes	Yes
Temperature Cycle	1010	N/A	Cond B	Cond C	Cond C
Constant Acceleration	2001, Y1 Axis	N/A	500 Gs	3000 Gs	3000 Gs
PIND	2020	N/A	N/A	N/A	N/A
Burn-In	1015	N/A	48 hrs@hi temp	160 hrs@125°C	160 hrs@125°C
Final Electrical (Group A)	MIL-PRF-38534 & Specification	25°C	25°C ②	-55°C, +25°C, +125°C	-55°C, +25°C, +125°C
PDA	MIL-PRF-38534	N/A	N/A	N/A	10%
Seal, Fine and Gross	1014	Cond A	Cond A, C	Cond A, C	Cond A, C
Radiographic	2012	N/A	N/A	N/A	N/A
External Visual	2009	①	Yes	Yes	Yes

Notes:

- ① Best commercial practice
- ② Sample tests at low and high temperatures
- ③ -55°C to +105°C for AHE, ATO, ATW

Part Numbering

