

**HIGH RELIABILITY, HIGH EFFICIENCY
RADIATION HARDENED
DC-DC CONVERTER**

**GH-SERIES
28V Input, Single Output**

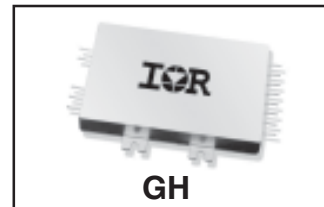

Description

The GH series is a family of low voltage single output DC-DC converters. They are specifically designed in response to the need for low voltage at moderate current levels with the high efficiency and tight regulation dictated by modern digital processing applications. The converters are radiation hardened, high reliability converters designed for extended operation in hostile environments. Their small size and low weight make them ideal for applications such as geostationary earth orbit satellites and deep space probes. They exhibit a high tolerance to total ionizing dose, single event effects and environmental stresses such as temperature extremes, mechanical shock, and vibration. All components are fully de-rated to meet the requirements of MIL-STD-975, MIL-STD-1547, GSFC PPL-21 Appendix B, and ESA-PSS-01-301. Thorough analyses and documentation including beginning-of-life (BOL) and end-of-life (EOL) electrical worst case (WCA) operation, component stress and de-rating, radiation susceptibility (TREE), thermal stress, failure mode and effects (FMEA), and reliability (MTBF) are available for customer review.

The design incorporates a fixed frequency topology with magnetic feedback. Synchronous rectification is deployed to maximize efficiency performance. The converters include an internal EMI filter that is capable of meeting the conducted emission requirements of most major satellite power busses. Incorporation of many functional features including on/off command, remote sensing, and under-voltage lockout make the design suitable for today's space design applications.

The converter is enclosed in a hermetically sealed package with the overall dimensions of 3.5"L x 2.50"W x 0.475"H including the I/O pins and mounting tabs. The package base material is silicon carbide-aluminum (AISIC). The package ring frame is Alloy 48. The package utilizes rugged ceramic feed-through copper core I/O pins and is sealed using parallel seam welding. The total mass of a converter is less than 110 grams.

www.irf.com

Features

- Total Ionizing Dose (TID) > 100 KRad(Si)
- SEE Hardened to LET Level > 82 MeV.cm²/mg
- Internal EMI filter
- Low Weight, < 110 grams
- Magnetically Coupled Feedback
- 18V to 40V DC Input Range
- Up to 50W Output Power
- Single Output Models Include 1V, 1.5V, 1.8V, 2.5V, 3.3V and 5V
- High Efficiency - to 87%
- -55°C to +85°C Operating Temperature Range
- 100MΩ @ 100VDC Isolation
- Under-Voltage Lockout
- Short Circuit and Overload Protection
- Output Voltage Adjust
- Synchronization Output and Input
- Remote Sense
- External Inhibit

Applications

- Deep Space Satellites / Probes
- Strategic Weapons and Communication System
- Geostationary Earth Orbit Satellites (GEO)

Manufactured in a facility fully qualified to MIL-PRF-38534, these converters are fabricated utilizing DSCC qualified processes. For available screening options, refer to device screening table in the data sheet.

Non-flight versions of the GH-Series converters are available for system development purposes. Variations in electrical specifications and screening to meet custom requirements can be accommodated.

Specifications

Absolute Maximum Ratings		Recommended Operating Conditions	
Input voltage range	-0.5Vdc to +50Vdc	Input voltage range	+18Vdc to +40Vdc
Output power	Internally limited	Output power	0 to Max. Rated
Lead temperature	+300°C for 10 seconds	Operating temperature	-55°C to +85°C
Operating temperature	-55°C to +125°C	Operating temperature ¹	-55°C to +80°C
Storage temperature	-55°C to +135°C		

¹ Meets derating per MIL-STD-975

Electrical Performance Characteristics

Parameter	Group A Subgroup	Conditions -55°C ≤ T _C ≤ +85°C V _{IN} = 28V DC ± 5%, C _L = 0 unless otherwise specified	Limits			Unit		
			Min	Nom	Max			
Input Voltage			18	28	40	V		
Output Voltage (V _{OUT})			Note 3		Note 3			
GH2801S	1	I _{OUT} = 100% rated load	0.98	1.00	1.02	V		
GH2801R5S	1		1.48	1.50	1.52			
GH2801R8S	1		1.77	1.80	1.83			
GH2802R5S	1		2.47	2.50	2.53			
GH2803R3S	1		3.28	3.30	3.32			
GH2805S	1		4.98	5.00	5.02			
GH2801S	2,3		0.96		1.04			
GH2801R5S	2,3		1.45		1.55			
GH2801R8S	2,3		1.75		1.85			
GH2802R5S	2,3		2.45		2.55			
GH2803R3S	2,3		3.24		3.36			
GH2805S	2,3		4.93		5.07			
Output power (P _{OUT})			V _{IN} = 18, 28, 40 Volts, Note 2					
GH2801S	1,2,3			0			20	W
GH2801R5S			0		30			
GH2801R8S			0		36			
GH2802R5S			0		50			
GH2803R3S			0		50			
GH2805S			0		50			
Output current (I _{OUT})		V _{IN} = 18, 28, 40 Volts, Note 2						
GH2801S	1,2,3		0		20	A		
GH2801R5S			0		20			
GH2801R8S			0		20			
GH2802R5S			0		20			
GH2803R3S			0		15.15			
GH2805S			0		10			
Line regulation (VR _{LINE})	1,2,3	V _{IN} = 18, 28, 40 Volts I _{OUT} = 0, 50%, 100% rated	-10		10	mV		
Load regulation (VR _{LOAD})	1,2,3	I _{OUT} = 0, 50%, 100% rated V _{IN} = 18, 28, 40 Volts	-0.5		0.5	%		
Input current (I _{IN})	1,2,3	I _{OUT} = 0, Pin 3 open		130	200	mA		
		Pin 3 shorted to pin 2		2.0	5.0			

For Notes to Electrical Performance Characteristics, refer to page 4

Electrical Performance Characteristics (continued)

Parameter	Group A Subgroup	Conditions -55°C ≤ T _C ≤ +85°C V _{IN} = 28V DC ± 5%, C _L = 0 unless otherwise specified	Limits			Unit
			Min	Nom	Max	
Switching frequency (F _s)	1,2,3	Sync. Input (Pin 4) open	450	500	550	KHz
Synchronization Input frequency range pulse high level pulse low level pulse transition time pulse duty cycle		Ext. Clock on Sync. Input (Pin 4) Note 1	450 4.0 -0.5 80 20		600 10.0 0.5 80	KHz V V V/μs %
Output ripple (V _{RIP}) GH2801S GH2801R5S GH2801R8S GH2802R5S GH2803R3S GH2805S	1,2,3	I _{OUT} = 100% rated load Note 4		5 5 5 10 10 10	15 15 15 25 25 30	mV p-p
Efficiency (E _{FF}) GH2801S GH2801R5S GH2801R8S GH2802R5S GH2803R3S GH2805S	1	I _{OUT} = 100% rated load	70 72 75 81 83 85	73 75 78 84 85 87		%
Inhibit Input open circuit voltage drive current (sink) voltage range	1,2,3	Note 1	3.0 -0.5		5.0 100 50	V μA V
Current Limit Point Expressed as a percentage of full rated load current	1,2,3	V _{out} = 90% of Nominal		125	135	%
Power dissipation, load fault (P _D)	1,2,3	Short Circuit, Overload, Note 6		17	25	W
Output response to step load changes (V _{TLD}) GH2801S GH2801R5S GH2801R8S GH2802R5S GH2803R3S GH2805S	4,5,6	Half Load to/from Full Load, Note 7	-300 -300 -300 -300 -300 -300		300 300 300 300 300 300	mV pk
Recovery time, step load changes (T _{TLD}) GH2801S GH2801R5S GH2801R8S GH2802R5S GH2803R3S GH2805S	4,5,6	Half Load to/from Full Load, Notes 7, 8			250 250 250 250 250 250	μs
Output response to step line changes (V _{TLN})	4,5,6	24V to/from 32V I _{OUT} = 100% rated load, Notes 1, 9	-50		50	mV pk
Recovery time, step line changes (T _{TLN})	4,5,6	24V to/from 32V I _{OUT} = 100% rated load, Notes 1, 8, 9			200	μs
Turn-on Response Overshoot (V _{OSH}) Turn-on Delay (T _{DLY})	4,5,6	No Load, Full Load Note 10	0		250 5.0	mV ms

For Notes to Electrical Performance Characteristics, refer to page 4

Electrical Performance Characteristics (continued)

Parameter	Group A Subgroup	Conditions -55°C ≤ T _C ≤ +85°C V _{IN} = 28V DC ± 5%, C _L = 0 unless otherwise specified	Limits			Unit
			Min	Nom	Max	
Capacitive Load (C _L)	1	I _{OUT} = 100% rated load No effect on DC performance Notes 1, 5			5000	μF
Line Rejection	1	I _{OUT} = 100% rated load DC to 50KHz, Note 1	40	60		dB
Electromagnetic Interference (EMI), conducted emission (C _E)	1	I _{OUT} = 100% rated load, Note 1	Per Fig. 3			
Isolation	1	Input to Output or Any Pin to Case except pin 13, test @ 100VDC	100			MΩ
Device Mass					110	g
MTBF		MIL-HDBK-217F2, SF, 35°C, Note 11	5.8x10 ⁶			Hrs

Notes for the Electrical Performance Characteristics Table

- Parameter is tested as part of design characterization or after design changes. Thereafter, parameter shall be guaranteed to the limits specified.
- Parameter verified during line and load regulation tests.
- These are beginning-of-life (BOL) limits. End-of-life (EOL) limits are -3% and +3% of nominal limit for Min and Max, respectively.
- Guaranteed for a D.C. to 20MHz bandwidth. Tested using a 20KHz to 10MHz bandwidth.
- Capacitive load may be any value from 0 to the maximum limit without compromising dc performance. A capacitive load in excess of the maximum limit may interfere with the proper operation of the converter's overload protection, causing erratic behavior during turn-on.
- Overload power dissipation is defined as the device power dissipation with the load set such that V_{OUT} = 90% of nominal.
- Load step slew rate ≤ 0.5A/μs.
- Recovery time is measured from the initiation of the transient to where V_{OUT} has returned to within ±1% of its steady state value.
- Line step slew rate ≤ 1.0V/μs.
- Turn-on delay time from either a step application of input power or a logic low to a logic high transition on the inhibit pin (pin 3) to the point where V_{OUT} = 90% of nominal.
- MIL-HDBK MOSFET failure rates replaced by empirical failure rate data supplied by International Rectifier.

Radiation Performance Characteristics

Test	Conditions	Min.	Typ.	Unit
Total Ionizing Dose (Gamma)	MIL-STD-883, Method 1019 Operating bias applied during exposure, Full Rated Load, V _{IN} = 28V	100		KRads (Si)
Single Event Effects SEU, SEL, SEGR, SEB	Heavy Ions (LET) Operating bias applied during exposure, Full Rated Load, V _{IN} = 28V	82		MeV•cm ² / mg

Fig. 1 –Typical Efficiency vs Output Current @ 25°C, 5V Output (GH2805S)

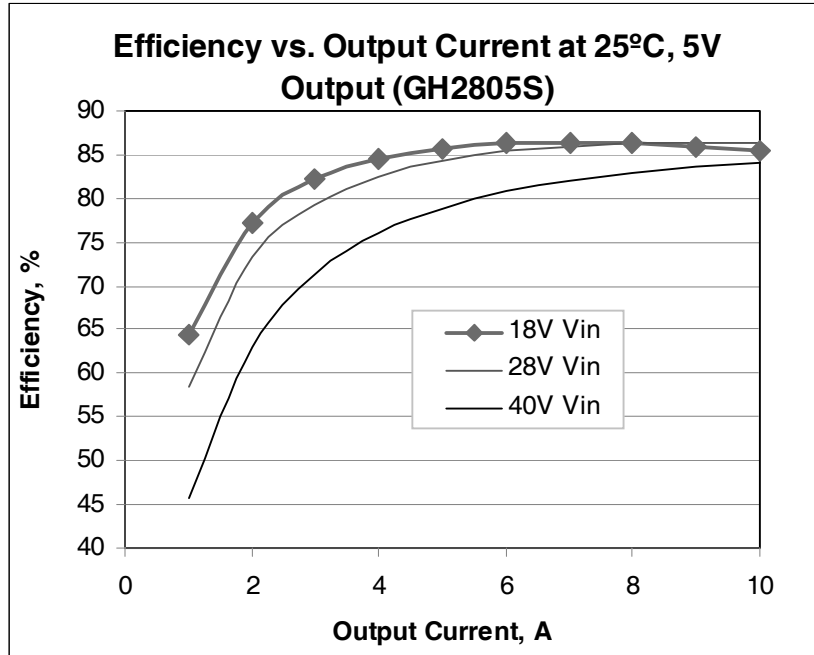

Fig. 2 –Typical Efficiency vs Temperature, 5V Output (GH2805S)

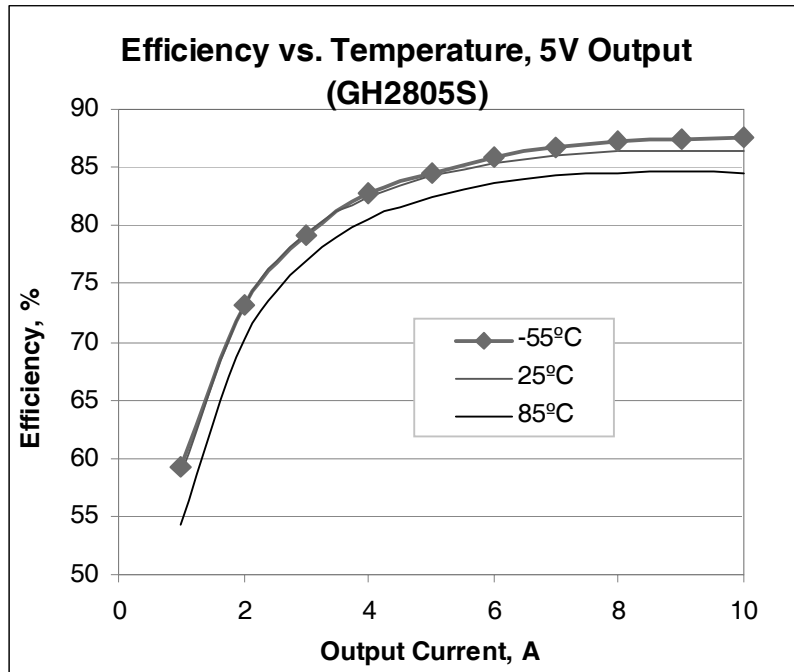

Fig. 3 – EMI CE03 Specification Limits and Typical Performance

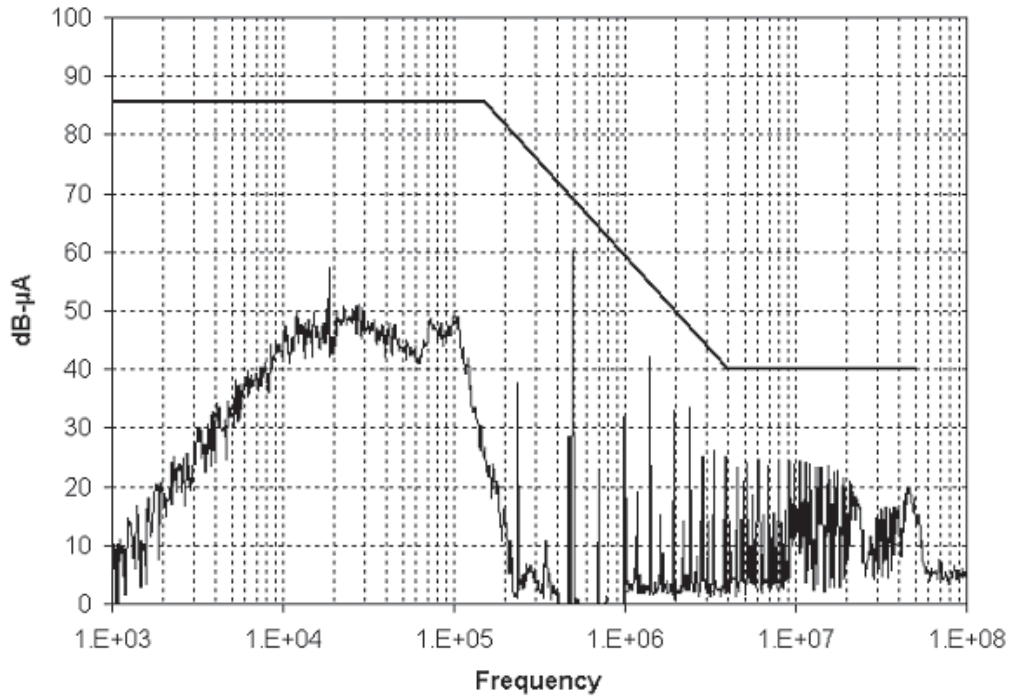
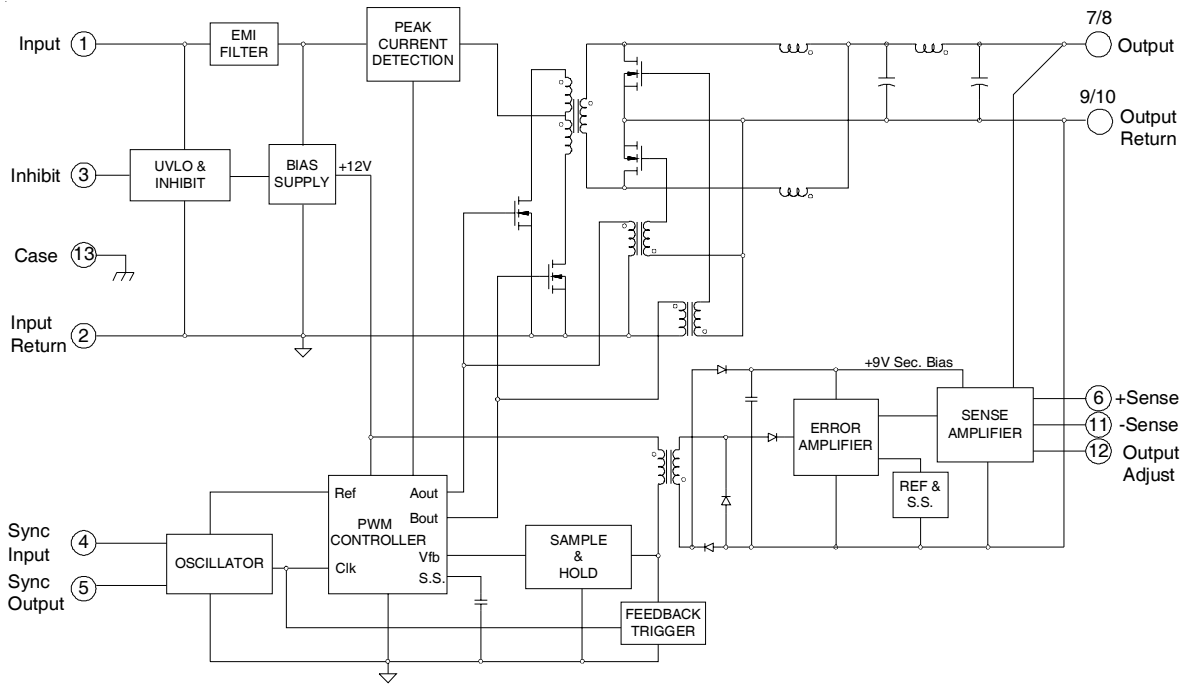

Fig. 4 Block Diagram - Single Output



Application Note:

The GH-Series converters have an *Output Adjust* pin (pin 12), which when connected via an external resistor (R_{ADJ}) to either the $-sense$ (pin 11) or $+sense$ (pin 6), allows the nominal output voltage to be adjusted. Use the following equations with the parameters listed in Table 1 to calculate the required resistor value (R_{ADJ}).

For **all Models**, to adjust the output voltage higher:

$$R_{ADJ} = \frac{2 \times A}{V_{OUT} - V_{NOM}} - B$$

where: R_{ADJ} is in Kohms

R_{ADJ} is connected to $-sense$ and $V_{NOM} < V_{OUT} < 1.1V_{NOM}$

V_{NOM} is the nominal output voltage with the Adjust Pin left open

V_{OUT} is the desired output voltage

A and B are parameters defined in Table 1

For **all Models**, to adjust the output voltage lower:

$$R_{ADJ} = \frac{1}{\left(\frac{A}{C(V_{OUT} - A)} - 0.5 \right)} - B$$

where: R_{ADJ} is in Kohms

R_{ADJ} is connected to $+sense$ and $D < V_{OUT} < V_{NOM}$

V_{NOM} is the nominal output voltage with the Adjust Pin left open

V_{OUT} is the desired output voltage

A, B, C and D are parameters defined in Table 1

Table 1. Equation Parameters by Model

MODEL	EQUATION PARAMETERS			
	A	B	C	D
GH2801S	0.714	14.3	5.0	0.965
GH2801R5S	0.937	12.6	3.33	1.425
GH2801R8S	1.047	11.5	2.78	1.689
GH2802R5S	1.25	10	2.0	2.292
GH2803R3S	1.425	8.34	1.52	2.937
GH2805S	1.667	6.68	1.0	4.233

Mechanical Diagram

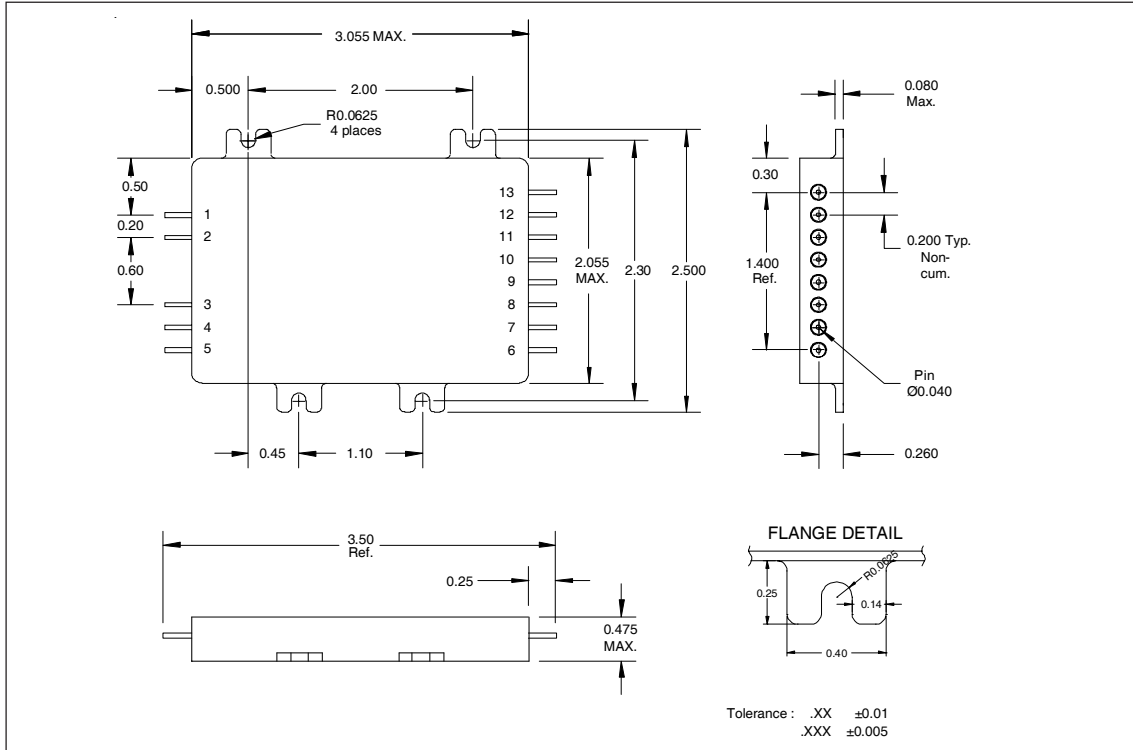

Pin Designation

Pin #	Designation	Pin #	Designation
1	Input	8	Output
2	Input Return	9	Output Return
3	Inhibit	10	Output Return
4	Sync Input	11	- Sense
5	Sync Output	12	Output Adjust
6	+ Sense	13	Case
7	Output		

Standard Microcircuit Drawing Equivalence Table

Standard Microcircuit Drawing Number	IR Standard Part Number
5962-1021701KXX	GH2803R3S/CKX
5962-1021901KXX	GH2805S/CKX

Device Screening

Requirement	MIL-STD-883 Method	No Suffix ②	CK ②	EM
Temperature Range	—	-55°C to +85°C	-55°C to +85°C	-55°C to +85°C
Element Evaluation	MIL-PRF-38534	Class K	Class K	N/A
Non-Destructive Bond Pull	2023	Yes	Yes	N/A
Internal Visual	2017	Yes	Yes	①
Temperature Cycle	1010	Cond C	Cond C	Cond C
Constant Acceleration	2001, Y1 Axis	3000 Gs	3000 Gs	3000 Gs
PIND	2020	Cond A	Cond A	N/A
Burn-In	1015	320 hrs @ 125°C (2 x 160 hrs)	320 hrs @ 125°C (2 x 160 hrs)	48 hrs @ 125°C
Final Electrical (Group A)	MIL-PRF-38534 & Specification	-55°C, +25°C, +85°C	-55°C, +25°C, +85°C	-55°C, +25°C, +85°C
PDA	MIL-PRF-38534	2%	2%	N/A
Seal, Fine and Gross	1014	Cond A, C	Cond A, C	Cond A
Radiographic	2012	Yes	Yes	N/A
External Visual	2009	Yes	Yes	①

Notes:

- ① Best commercial practice.
- ② CK is a DLA Land and Maritime (formerly DSCC) part marking used to designate a Class K compliant hybrid.
The CK marking does not indicate the hybrid is radiation certified.
No Suffix is a radiation rated device but not available as a DLA Land and Maritime qualified SMD per MIL-PRF-38534.
International Rectifier currently does not have a DLA Land and Maritime certified Radiation Hardness Assurance Program.

Part Numbering

GH 28 05 S /XX X

Model

Nominal Input Voltage
28 = 28V

Output Voltage
01 = 1V, 01R5 = 1.5V
01R8 = 1.8V, 02R5 = 2.5V
03R3 = 3.3V, 05 = 5V

Lead Finish for CK only

C = Gold Plated
A = Solder Dipped
Blank for No Suffix and EM
Lead finish for No Suffix = Gold Plated
Lead finish for EM depending on availability

Screening Level

(Please refer to Screening Table)
No Suffix, EM, CK

Number of Outputs

S = Single