

HIGH RELIABILITY HYBRID DC-DC CONVERTERS

Description

The ASAP Series of DC-DC converters are high reliability thick film hybrid converters that use flyback topology operating at a nominal frequency of 550KHz. High input to output isolation is achieved through the use of transformers in the flyback power and feedback circuits.

The advanced feedback design provides fast loop response for superior line and load transient characteristics and offers greater reliability than devices incorporating optical feedback circuits.

This device is designed to meet MIL-STD-704D input requirements offering full performance over a wide 15 to 50 volt input range and output power of up to 6.0 watts.

Connecting the inhibit pin (pin 5) to the input common (pin 7) will cause the converter to shut down. It is recommended that the inhibit pin be driven by an open collector device capable of sinking at least 400 μ A. The open circuit voltage of the inhibit pin is 11.5 \pm 0.5 volts.

These converters are manufactured in a facility fully qualified to MIL-PRF-38534. All processes used to manufacture these converters have been qualified thereby enabling International Rectifier to deliver fully compliant devices. Four standard temperature grades are offered with the screening options. Refer to Screening Level section. The CH grade converters are fully compliant to MIL-PRF-38534 for class H. The HB grade converters are processed with the same screening as the CH grade, but do not have class H element evaluation as required by MIL-PRF-38534. These two grades are fully tested and operate over the full military temperature range without derating of output power. A commercial grade is also available. Variations in electrical, mechanical and screening requirements can be accommodated. Extensive computer simulation using complex modeling allows design modifications to be examined. Contact IR San Jose with specific requirements.

www.irf.com

ASAP SERIES 28V Input, Single and Dual Output



Features

- Up To 6.0 Watt Output Power
- Available in Single and Dual Output Configurations
Single Outputs: 5V, 12V and 15V
Dual Outputs: \pm 5V, \pm 12V and \pm 15V
- High Reliability
- Wide Input Voltage Range, 15 To 50 Volts
- Indefinite Short Circuit and Overload Protection
- Popular Industry Standard Pin-Out
- Military Screening Available
- Parallel Seam Welded Package
- No External Capacitors Required
- Input Voltage Surge Protected to MIL-STD-704A
80V, 1 second
- Under Voltage Lockout

Absolute Maximum Ratings	
Input Voltage	-0.5V to 50V Continuous, 80V for 1 second
Power Output	Internally limited
Soldering Temperature	300°C for 10 seconds
Temperature Range	Operating -55°C to +125°C Case Storage -65°C to +150°C

TEST	Conditions -55° ≤ T _C ≤ +125°C V _{IN} = 28V dc ±5% C _L = 0 unless otherwise specified	Group A Subgroups	ASAP2805S/xx		ASAP2812S/xx		ASAP2815S/xx		Unit
			Min	Max	Min	Max	Min	Max	
Output voltage	I _{OUT} = 0	1	4.95	5.05	11.88	12.12	14.85	15.15	V
		2, 3	4.90	5.10	11.76	12.24	14.70	15.30	
Output current ¹	V _{IN} = 15, 28, and 50 V dc	1, 2, 3		1200		500		400	mA
Output ripple voltage ²	V _{IN} = 15, 28 and 50 V dc	1		60		60		60	mV _{PP}
		2, 3		100		100		100	
Line regulation	V _{IN} = 15, 28, and 50 V dc I _{OUT} = 0, 50%, 100% I _{MAX}	1		±25		±25		±25	mV
		2, 3		±50		±50		±50	
Load regulation	V _{IN} = 15, 28, and 50 V dc I _{OUT} = 0, 50%, 100% I _{MAX}	1		±25		±25		±25	mV
		2, 3		±50		±50		±50	
Input current	I _{OUT} = 0 Pin 5 to Pin 7	1, 2, 3		18		18		18	mA
	I _{OUT} = 0 Pin5 open			50		50		50	
Input ripple current ²	I _{OUT} = I _{MAX}	1, 2, 3		100		100		100	mA _{PP}
Efficiency	I _{OUT} = I _{MAX}	1	66		71		71		%
		2, 3			68		68		
Isolation - Input to output or any pin to case	V _{TEST} 500 Vdc, T _C = +25°C	1	100		100		100		MΩ
Capacitive load ^{3, 4}	No effect on dc performance, T _C = +25°C	4		500		200		200	μF
Power dissipation, load fault	Overload ⁵	1, 2, 3		5.0		5.0		5.0	W
	Short circuit			2.0		2.0		2.0	
Switching frequency ⁴	I _{OUT} = I _{MAX}	4, 5, 6	500	600	500	600	500	600	KHz
Output response to step transient load changes ⁶	½ I _{MAX} ⇔ I _{MAX}	4	-300	+300	-450	+450	-450	+450	mV pk
		5, 6	-450	+450					
	0 mA ⇔ I _{MAX}	4	-500	+500	-750	+750	-750	+750	
		5, 6	-750	+750					
Recovery time, step transient load changes	I _{OUT} = I _{MAX}	4, 5, 6		200		100		100	μs
	0 mA ⇔ ½ I _{MAX}			1.0		1.0		1.0	ms
Output response transient step line changes ^{4, 8}	Input step 15 ⇔ 50 V dc I _{OUT} = I _{MAX}	4, 5, 6	-500	500	-1000	1000	-1000	1000	mV pk
Recovery time transient step line changes ^{4, 7, 8}	Input step 15 ⇔ 50 V dc I _{OUT} = I _{MAX}	4, 5, 6		800		800		800	μs
Turn on overshoot	I _{OUT} = 0 mA, I _{MAX}	4, 5, 6		600		750		750	mV pk
Turn on delay ⁹	I _{OUT} = 0 or I _{MAX}	4, 5, 6		20		25		25	ms
Load fault recovery ⁴		4, 5, 6		20		25		25	ms

For Notes to Specifications, refer to page 3

Notes to Specifications for Tables on page 2

1. Parameter guaranteed and measured during line and load regulation tests.
2. Bandwidth guaranteed by design. Tested for 20 KHz to 2.0 MHz.
3. Capacitive load may be any value from 0 to the maximum limit without compromising dc performance. A capacitive load in excess of the maximum limit will not disturb loop stability but may interfere with the operation of the load fault detection circuitry, appearing as a short circuit during turn-on.
4. Parameter shall be tested as part of design characterization and after design or process changes.
5. An overload is that condition of load in excess of rated load but less than that necessary to trigger the short circuit protection and is the condition of maximum power dissipation.
6. Load step transition time between 2.0 and 10 microseconds.
7. Recovery time is measured from the initiation of the transient to where V_{OUT} has returned to within ± 1.0 percent of V_{OUT} at 50% load.
8. Input step transition time between 2.0 and 10 microseconds.
9. Turn-on delay time measurement is for either a step application of power at the input or the removal of a ground signal from the inhibit pin (pin 2) while power is applied to the input.

Absolute Maximum Ratings	
Input Voltage	-0.5V to 50V Continuous, 80V for 1 second
Power Output	Internally limited
Soldering Temperature	300°C for 10 seconds
Temperature Range	Operating -55°C to +125°C Case Storage -65°C to +150°C

TEST	Conditions -55° ≤ T _C ≤ +125°C V _{IN} = 28V dc ±5% C _L = 0 unless otherwise specified	Group A Subgroups	ASAP2805D/XX		ASAP2812D/XX		ASAP2815D/XX		Unit
			Min	Max	Min	Max	Min	Max	
Output voltage	I _{OUT} = 0	1	±4.95	±5.05	±11.88	±12.12	±14.85	±15.15	V
		2, 3	±4.90	±5.10	±11.76	±12.24	±14.70	±15.30	
Output current ^{1, 2}	V _{IN} = 15, 28, and 50 Vdc either output	1, 2, 3	240	960	100	400	80	320	mA
Output ripple voltage ^{3, 4}	V _{IN} = 15, 28 and 50 Vdc	1, 2, 3		100		200		200	mV _{PP}
Line regulation ⁴	V _{IN} = 15, 28, and 50 Vdc I _{OUT} = 0, 50%, 100% I _{MAX}	1, 2, 3		±50		±50		±50	mV
Load regulation ⁴	V _{IN} = 15, 28, and 50 Vdc I _{OUT} = 0, 50%, 100% I _{MAX}	1, 2, 3		±50		±50		±50	mV
Cross regulation ⁵	20% to 80% load change	1, 2, 3		15		8.0		8.0	%
Input current	I _{OUT} = 0 Pin 5 connected to pin 7	1, 2, 3		12		12		12	mA
	I _{OUT} = 0 Pin5 open			60		60		60	
Input ripple current ^{3, 4}	I _{OUT} = I _{MAX}	1, 2, 3		100		100		100	mA _{PP}
Efficiency ⁴	I _{OUT} = I _{MAX}	1, 3	70		71		71		%
		2	66		68		68		
Isolation	Input to output or any pin to case (except pin 8) at 500 Vdc, T _C = +25° C	1	100		100		100		MΩ
Capacitive load ^{6, 7}	No effect on dc performance, total for both outputs	4	200			200		200	μF
Power dissipation load fault	Overload ⁸	1, 2, 3		5.0		5.0		5.0	W
	Short circuit			2.0		2.0		2.0	
Switching frequency ⁴	I _{OUT} = I _{MAX}	4, 5, 6	500	600	500	600	500	600	KHz
Output response to step transient load changes ^{4, 9}	I _{OUT} = 50% ⇔ 100% I _{MAX}	4, 5, 6	-400	+400	-400	+400	-400	+400	mV pk
	I _{OUT} = 0 ⇔ 50% I _{MAX}		-800	+800	-800	+800	-800	+800	
Recovery time, step transient load changes ^{4, 9, 10}	I _{OUT} = 50% ⇔ 100% I _{MAX}	4, 5, 6		100		100		100	μs
	I _{OUT} = 0 ⇔ 50% I _{MAX}			2000		2000		2000	
Output response transient step line changes ^{4, 7, 11}	V _{IN} = 15 ⇔ 50Vdc, I _{OUT} = I _{MAX}	4, 5, 6	-750	+750	-750	+750	-750	+750	mV pk
Recovery time transient step line changes ^{4, 7, 10, 11}	V _{IN} = 15 ⇔ 50Vdc, I _{OUT} = I _{MAX}	4, 5, 6		1200		1200		1200	μs
Turn on overshoot ⁴	I _{OUT} = 0 and I _{MAX}	4, 5, 6		600		600		600	mV pk
Turn on delay ^{4, 12}	I _{OUT} = 0 and I _{MAX}	4, 5, 6		25		25		25	ms
Load fault recovery ⁷		4, 5, 6		25		25		25	ms

For Notes to Specifications, refer to page 5

Notes to Specifications for Table on page 4

1. Parameter guaranteed by line, load, and cross regulation tests.
2. Up to 80% of full power is available from either output provided the total output does not exceed 6.0 W.
3. Bandwidth of DC to 20 MHz is guaranteed by design. Tested for 20 KHz to 2.0 MHz.
4. Load current split equally between $+V_{OUT}$ and $-V_{OUT}$.
5. 1.2 watt load on output under test, 1.2 to 4.8 watt load change on other output.
6. Capacitive load may be any value from 0 to the maximum limit without compromising DC performance. A capacitive load in excess of the maximum limit will not disturb loop stability but may interfere with the operation of the load fault detection circuitry, appearing as a short circuit during turn-on.
7. Parameter shall be tested as part of design characterization and after design or process changes. Thereafter, parameters shall be guaranteed to the limits specified.
8. An overload is a condition with a load in excess of rated but less than that necessary to trigger the short circuit protection and is the condition of maximum power dissipation.
9. Load step transition time between 2.0 and 10 microseconds.
10. Recovery time is measured from the initiation of the transient to where V_{OUT} has returned to within ± 1.0 percent of V_{OUT} at 50% load.
11. Input step transition time between 2.0 and 10 microseconds.
12. Turn-on delay time measurements is for either a step application of power at the input or the removal of ground connection from enable pin (pin 5) with power applied to the input.

Single Output - Block Diagram

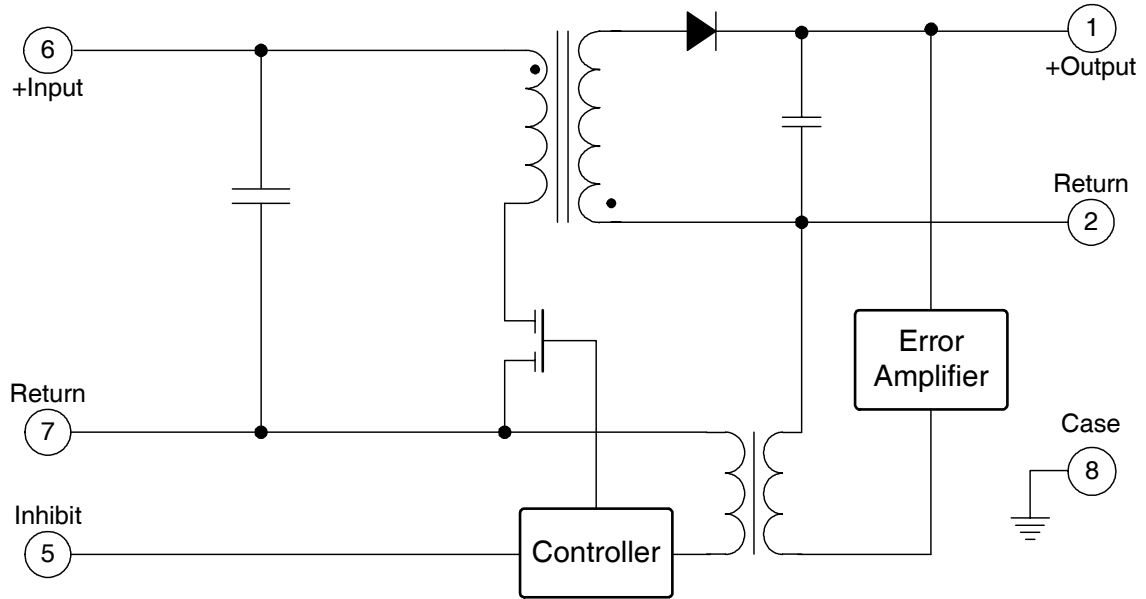

Dual Output - Block Diagram

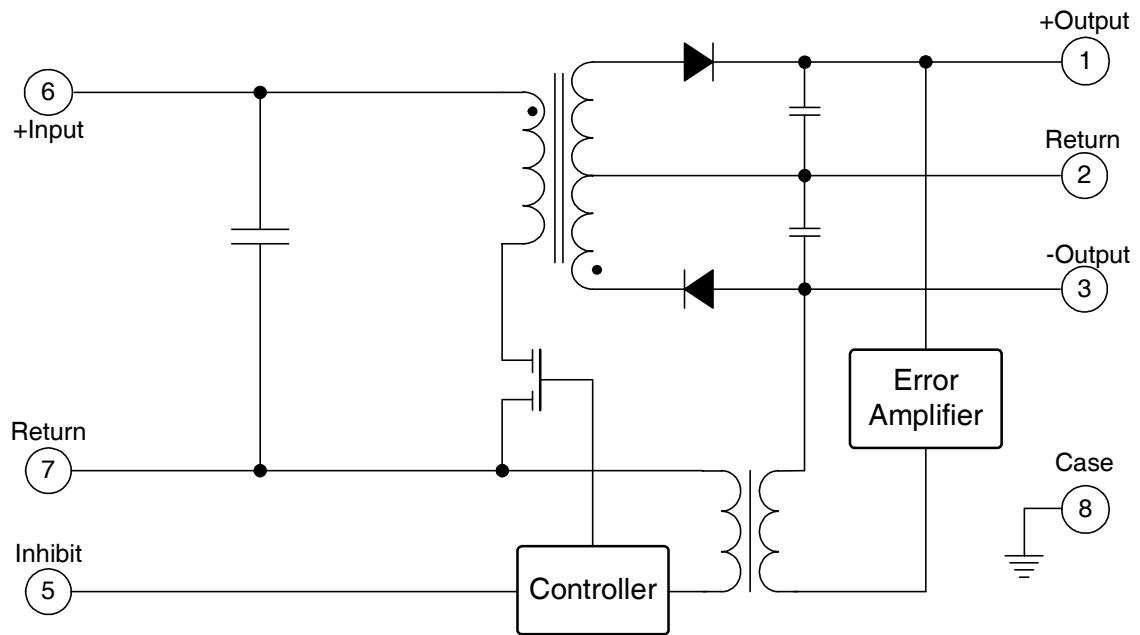

Case Outline

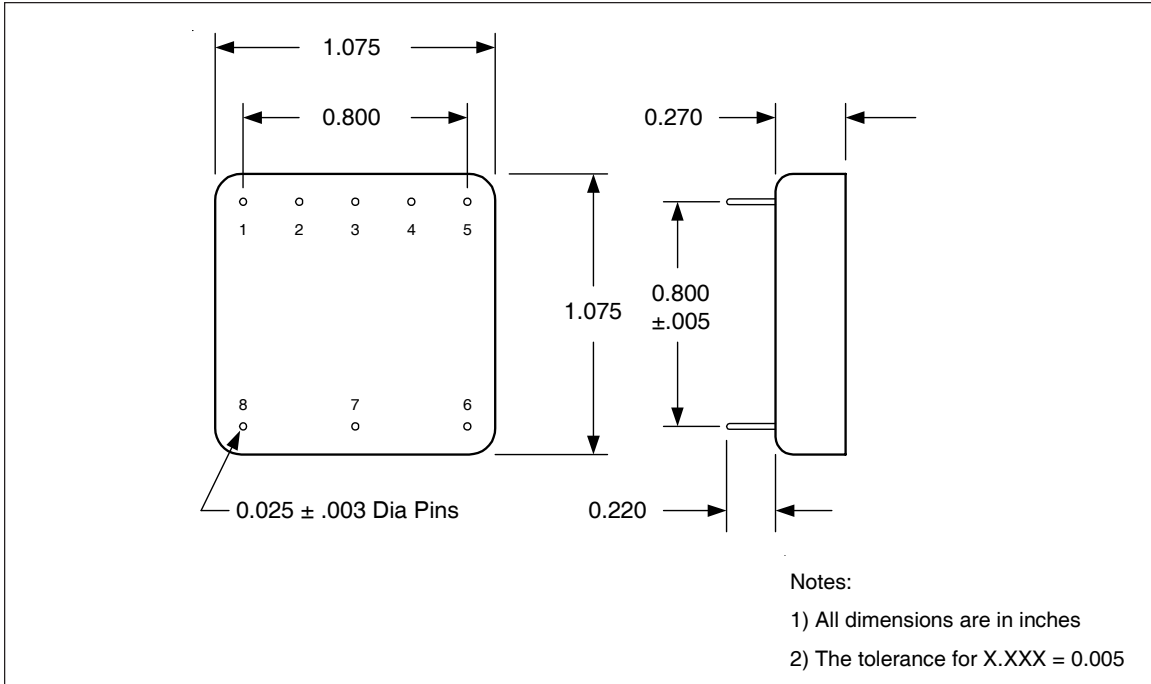

Single Output - Pin Designation

Pin #	Designation
1	+ Output
2	Output Return
3	N/C
4	N/C
5	Inhibit
6	+ Input
7	Input Return
8	Case

Dual Output - Pin Designation

Pin #	Designation
1	+ Output
2	Output Return
3	- Output
4	N/C
5	Inhibit
6	+ Input
7	Input Return
8	Case

Device Screening

Requirement	MIL-STD-883 Method	No Suffix	ES ②	HB	CH
Temperature Range	—	-20°C to +85°C	-55°C to +125°C	-55°C to +125°C	-55°C to +125°C
Element Evaluation	MIL-PRF-38534	—	—	—	Class H
Internal Visual	2017	①	Class H	Class H	Class H
Temperature Cycle	1010	—	Cond B	Cond C	Cond C
Constant Acceleration	2001, Y1 Axis	—	500 Gs	3000 Gs	3000 Gs
PIND	2020	—	—	—	—
Burn-In	1015	—	48 hrs @ 125°C	160 hrs@125°C	160 hrs@125°C
Final Electrical (Group A)	MIL-PRF-38534 & Specification	25°C	25°C ②	-55°C, +25°C, +125°C	-55°C, +25°C, +125°C
PDA	MIL-PRF-38534	—	—	10%	10%
Seal, Fine and Gross	1014	Cond A	Cond A, C	Cond A, C	Cond A, C
Radiographic	2012	—	—	—	—
External Visual	2009	①	Yes	Yes	Yes

Notes:

- ① Best commercial practice
- ② Samples tests at low and high temperatures

Part Numbering

