

**HiRel™ INT-A-Pak 2, PLASTIC
 HALF-BRIDGE IGBT MODULE**

G450HHBK06P2

Product Summary

Part Number	V _{CE}	I _C	V _{CE(SAT)}
G450HHBK06P2	600V	450A	1.8



The HiRel™ INT-A-Pak series are isolated near hermetic power modules which combine the latest IGBT and Soft Recovery Rectifier Technology. The module uses both high-speed and low V_{ce(sat)} IGBT's packaged for ultra low thermal resistance junction to case. The G450HHBK06P2 power module consists of six IGBT's and six FRED's in a Phase- Leg or Half-Bridge configuration.

Features:

- Rugged, Lightweight near Hermetic Package with Integrated Power Terminal Cap
- Gen IV IGBT Technology
- Soft Recovery Rectifiers
- Ultra-Low Thermal Resistance
- Zener Gate Protection
- Very Low Conduction and Switching Loss
- -55°C to +125°C Operating Temperature
- Screening to meet the intent of MIL-PRF-38534 Class H
- Short Circuit Capability
- 2.0 Ohms Series Gate Resistor
- High Altitude Operation, 85,000 Feet Above Sea Level at Rated Voltage

Absolute Maximum Ratings @ T_j=25°C (unless otherwise specified)

Parameter	Symbol	Value	Units
Collector-to-Emitter Voltage	V _{CES}	600	V
Gate-to-Emitter Voltage	V _{GE}	±20	
Continuous Collector Current @ T _c = 25°C	I _C	600	A
Continuous Collector Current @ T _c = 70°C		450	
Isolation Voltage	V _{ISOL}	2500	V _{RMS}

Electrical Characteristics @ T_j = 25°C (unless otherwise specified)

Parameter	Symbol	Test Conditions	Min.	Typ.	Max.	Units
Off Characteristics						
Collector Emitter Breakdown Voltage	V _{CES}	V _{GE} = 0V	600	-	-	V
Zero Gate Voltage Collector Current	I _{CES}	V _{GE} = 0V, V _{CE} = 600V	-	-	2.0	mA
Gate Emitter Leakage Current	I _{GES}	V _{GE} = ±15V, V _{CE} = 0V	-	-	10	μA
On Characteristics						
Gate Threshold Voltage	V _{GE(TH)}	V _{CE} = V _{GE} , I _C = 45mA	4.0	-	7.5	V
Collector Emitter Saturation Voltage	V _{CE(SAT)}	V _{GE} = 15V, I _C = 450A	-	1.8	2.6	
Dynamic Characteristics						
Total Gate Charge	Q _g	V _{CE} = 300V, I _C = 450A, V _{GE} = 15V	-	2,600	-	nC
Input Capacitance	C _{IES}	V _{GE} = 0V, V _{CE} = 25V, f = 1.0MHz	-	48	-	nF
Output Capacitance	C _{OES}		-	3.0	-	
Reverse Transfer Capacitance	C _{RES}		-	0.3	-	
Switching Inductive Load Characteristics						
Turn-On Delay Time	t _{d(on)}	V _{CC} = 300V, I _C = 450A, V _{GE} = 15V R _{G(on)} = 20Ω, R _{G(off)} = 10Ω, L = 100μH	-	800	900	ns
Rise Time	t _r		-	460	700	
Turn-On Losses	E _{on}		-	45	-	mJ
Turn-Off Delay Time	t _{d(off)}		-	2800	3400	ns
Fall Time	t _f		-	400	500	
Turn-Off Losses	E _{off}		-	60	-	mJ
Diode Characteristics						
Forward Voltage	V _F	I _F = 450A	-	1.2	1.8	V
Reverse Recovery Charge	Q _{rr}	V _R = 300V, I _C = 450A, di/dt = -1100A/μs	-	9.5	12	μC
Peak Reverse Recovery Current	I _{rr}		-	105	-	A
Reverse Recovery Time	t _{rr}		-	160	170	ns

Electrical Characteristics @ T_j = 125°C (unless otherwise specified)

Parameter	Symbol	Test Conditions	Min.	Typ.	Max.	Units
Off Characteristics						
Collector Emitter Breakdown Voltage	V _{CES}	V _{GE} = 0V	600	-	-	V
Zero Gate Voltage Collector Current	I _{CES}	V _{GE} = 0V, V _{CE} = 600V	-	-	18	mA
Gate Emitter Leakage Current	I _{GES}	V _{GE} = ±15V, V _{CE} = 0V	-	-	10	μA
On Characteristics						
Gate Threshold Voltage	V _{GE(TH)}	V _{CE} = V _{GE} , I _C = 45mA	4.0	-	7.5	V
Collector Emitter Saturation Voltage	V _{CE(SAT)}	V _{GE} = 15V, I _C = 450A	-	1.8	2.6	
Diode Characteristics						
Forward Voltage	V _F	I _F = 450A	-	1.2	1.8	V

Thermal-Mechanical Specifications

Parameter	Symbol	Min	Max	Units
IGBT Thermal Resistance, Junction to Case, per Switch	R _{thJC}	-	0.07	°C/W
Diode Thermal Resistance, Junction to Case, per Switch		-	0.12	
Operating Junction Temperature Range	T _J	-55	150	°C
Storage Temperature Range	T _{STG}	-55	125	
Screw Torque - Mounting	T	-	26	in-lbs
Screw Torque - Terminals		-	270	
Module Weight		-	270	

Module Screening

Test or Inspection	MIL-STD-883		Comments
	Method	Condition	
Internal Visual	2017		
Temperature Cycle	1010	B	10 Cycles, -55°C to +125°C
Mechanical Shock	2002	B	1500G, 0.5ms, 5 Times (Y1 direction only)
Burn-in	1015	A	160 Hrs @ +125°C
Final Electrical Test			Group A, -55°C, +25°C, +125°C
External Visual	2009		

G450HHBK06P2

Schematic

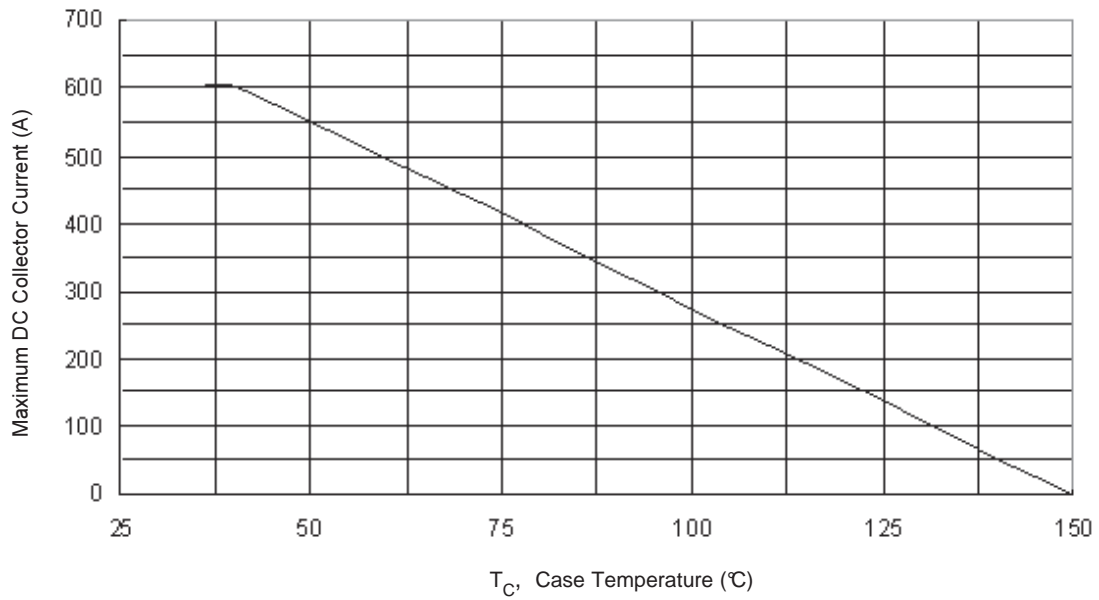
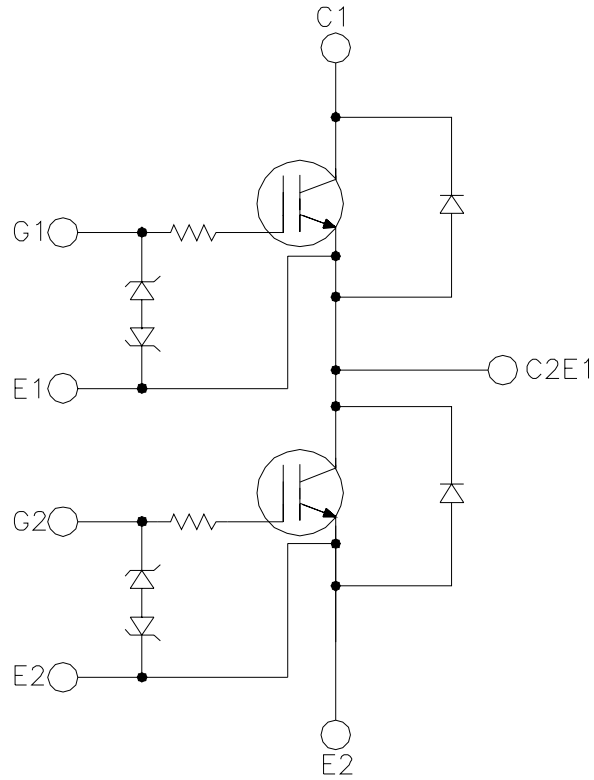

Fig 1: Maximum Collector Current Vs Case Temperature

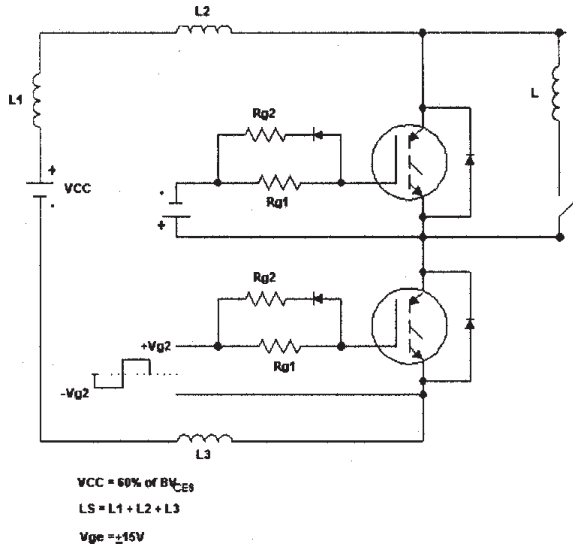

Fig. 2 - Test Circuit for Measurement of E_{on} , E_{off} , t_{rr} , Q_{rr} , I_{rr} , $t_{d(on)}$, t_r , $t_{d(off)}$, t_f

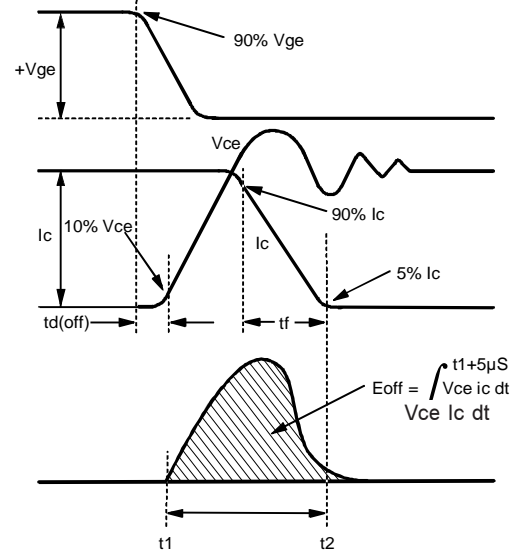

Fig. 3 - Test Waveforms for Circuit of Fig. 2, Defining E_{off} , $t_{d(off)}$, t_f

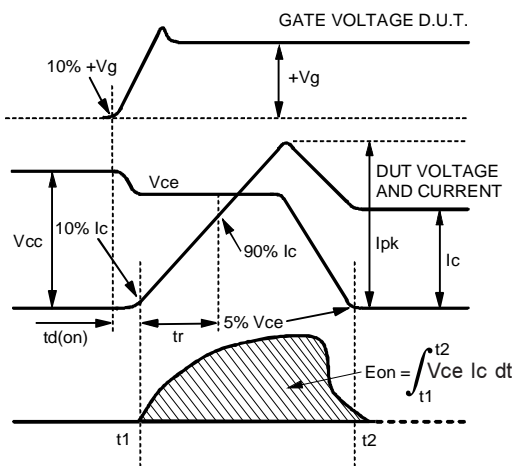

Fig. 3 - Test Waveforms for Circuit of Fig. 2, Defining E_{on} , $t_{d(on)}$, t_r

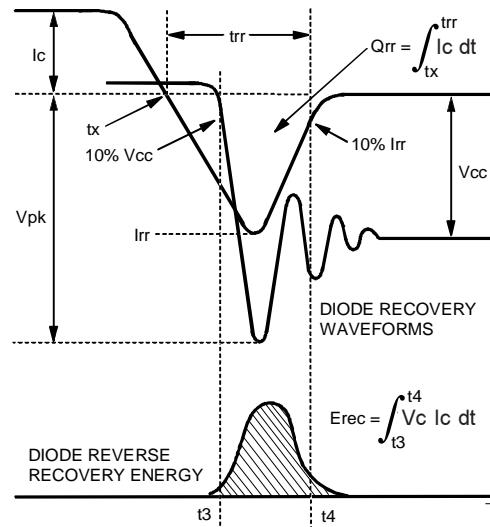
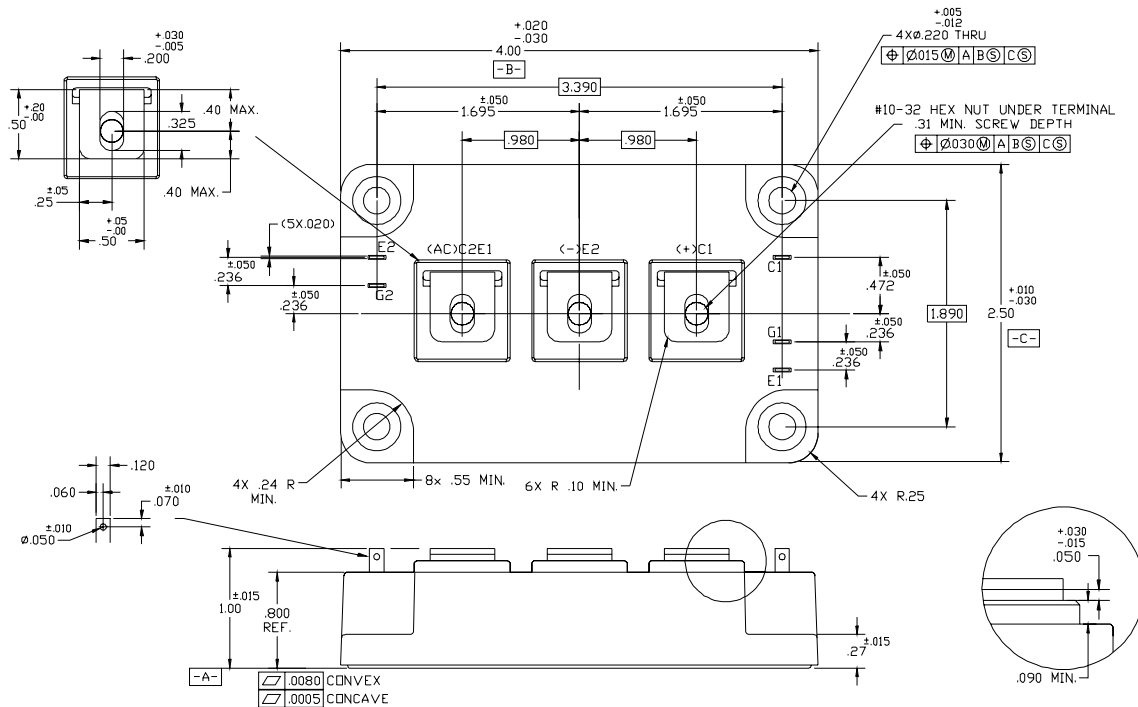

Fig. 4 - Test Waveforms for Circuit of Fig. 2, Defining E_{rec} , t_{rr} , Q_{rr} , I_{rr}

G450HHBK06P2

International
IR Rectifier

Case Outline and Dimensions - HiRel™ INT-A-Pak 2



Notes: 1) All dimensions are in inches
2) Unless otherwise specified,
Tolerances .XX = ±0.01, .XXX = ±0.005

Part numbering Nomenclature

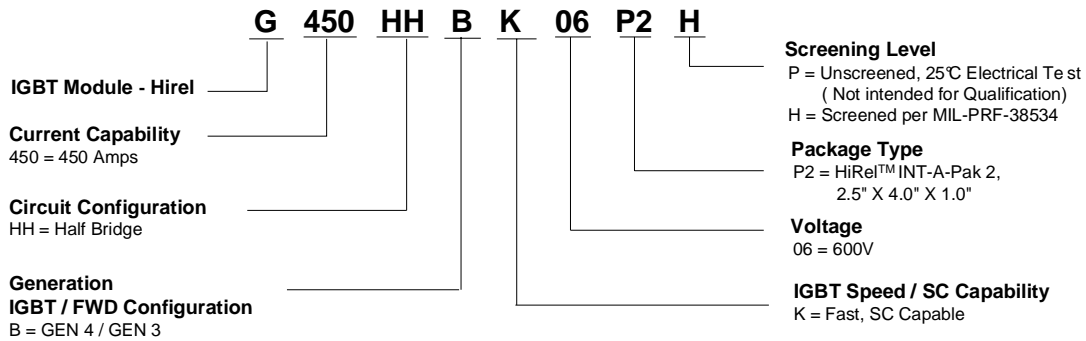

International
IR Rectifier

WORLD HEADQUARTERS: 233 Kansas St., El Segundo, California 90245, Tel: (310) 252-7105
IR LEOMINSTER: 205 Crawford St., Leominster, Massachusetts 01453, Tel: (978) 534-5776
Data and specifications subject to change without notice. 11/05