

**HiRel™ INT-A-Pak 3, PLASTIC
 FULL-BRIDGE IGBT MODULE**

G150SPBK06P3H

Product Summary

Part Number	V _{CE}	I _C	V _{CE(SAT)}	
			2.3V Typ.	2.6V Max.
G150SPBK06P3H	600V	150A		



The HiRel™ INT-A-Pak series are isolated near hermetic power modules which combine the latest IGBT and Soft Recovery Rectifier Technology. They use both high-speed and low V_{ce(sat)} IGBT for ultra low thermal resistance. The G150SPBK06P3H consists of six IGBTs and six FREDs in a full-bridge configuration and has an SCR inrush current limiter.

Features:

- Rugged, Light Weight near Hermetic Package with Integrated Power Terminals
- Gen IV IGBT Technology
- Soft Recovery Rectifier Diodes
- Ultra Low Thermal Resistance
- Zener Gate Protection Diodes
- Very Low Conduction and Switching Losses
- -55°C to +125°C Operation
- Screening to meet the intent of MIL-PRF-38534
- Short Circuit Capability
- 2.0 Ohms Series Gate Resistor
- High Altitude Operation, 85,000 Feet Above Sea Level at Rated Voltage

Thermal-Mechanical Specifications

Parameter	Symbol	Min	Typ	Max	Units
IGBT Thermal Resistance, Junction to Case, per Switch ①	R _{thJC}	-	0.2	0.24	°C/W
Inverter Bridge Diode Thermal Resistance, Junction to Case, per Switch ①		-	0.38	0.45	
Regen Diode Thermal Resistance, Junction to Case, per Switch ①		-	0.6	0.80	
SCR Thermal Resistance, Junction to Case ①		-	0.21	0.27	
Operating Junction Temperature Range	T _J	-55	-	150	°C
Storage Temperature Range	T _{STG}	-55	-	125	
Screw Torque - Mounting	T	-	-	26	in-lbs
Screw Torque - Terminals					
Module Weight		-	-	410	g

① Thermal Resistance measurements are at Steady State condition.

Absolute Ratings

Module Characteristics				
Symbol	Parameter	Test Conditions	Ratings	Units
V_{RMS}	Voltage Isolation	t = 1 min @ sea level Terminals to Case (All terminals shorted together)	2,500	V
T_C	Operating Case Temperature		-55 to +125	°C
T_{STG}	Storage Temperature			

IGBT Characteristics				
Symbol	Parameter	Test Conditions	Ratings	Units
$V_{CE(BR)}$	IGBT Collector to Emitter Breakdown Voltage	$V_{GE} = 0V, T_J = +25^{\circ}C$ to $+150^{\circ}C$	600	V
V_{CG}	Collector to Gate Voltage	$T_J = +25^{\circ}C$ to $+150^{\circ}C$	600	
V_{GE}	Gate to Emitter Voltage		±20	
I_{CC}	Collector Current Continuous	$V_{GE} = 15V, T_C = +25^{\circ}C$	150	A
I_{CM}	Collector Current Pulsed	$T_P = 1.0ms, T_C = +25^{\circ}C$	300	
T_{SC}	Short Circuit Withstand Time	$V_{CE} = 400V, V_{GE} = 15V, T_J = +150^{\circ}C$	10 (min)	μs
T_J	Operating Junction Temperature		-55 to +150	°C

Diode Characteristics				
Symbol	Parameter	Test Conditions	Ratings	Units
V_{DRM} / V_{RRM}	Max. Repetitive Peak and Off-state Voltage	$T_J = +125^{\circ}C$	600	V
I_F	Forward Current	$T_C = +25^{\circ}C$	150 ①	A
I_{FM}	Forward Surge Current	$T_P = 1.0ms, T_C = +25^{\circ}C$	300 ①	
T_J	Operating Junction Temperature		-55 to +150	°C

SCR Characteristics				
Symbol	Parameter	Test Conditions	Ratings	Units
V_{DRM} / V_{RRM}	Max. Repetitive Peak and Off-state Voltage	$T_J = +25^{\circ}C$	600	V
$I_{T(DC)}$	Max. Continuous Forward Current	$T_J = +80^{\circ}C$	100	A
I_{TSM}	Max. Peak Surge Current	1/2 Cycle @ 60Hz	500	
T_J	Operating Junction Temperature		-55 to +150	°C

① Current ratings apply to the free wheeling diodes and not the regen diodes

Static Characteristics

Module						
Symbol	Parameter	Test Conditions	Min	Typ	Max	Units
R_I	Insulation Resistance	From all Pins to Case, $V = 500V_{DC}$	10	-	-	$M\Omega$

IGBT						
Symbol	Parameter	Test Conditions	Min	Typ	Max	Units
I_{CES}	Collector Current	$V_{CE} = V_{CES}$, $V_{GE} = 0V$	-	-	1.0	mA
I_{GES}	Gate Leakage Current	$V_{GE} = V_{GES}$, $V_{CE} = 0V$	-	-	10	μA
$V_{GE(th)}$	Gate-Emitter Threshold Voltage	$I_C = 15mA$, $V_{CE} = 10V$	4.0	5.4	8.1	V
$V_{CE(sat)}$	Collector-Emitter Saturation Voltage	$I_C = 150A$, $V_{GE} = 15V$ $I_C = 75A$, $V_{GE} = 15V$	-	2.3	2.6	

Diode						
Symbol	Parameter	Test Conditions	Min	Typ	Max	Units
V_{FM}	Diode Forward Voltage	Bridge Diodes, $I_E = 150A$, $V_{GE} = 0V$	-	1.8	2.1	V
		Regen Diodes, $I_E = 50A$, $V_{GE} = 0V$	-	-	2.4	

SCR						
Symbol	Parameter	Test Conditions	Min	Typ	Max	Units
I_{RRM}	Max. Peak Reverse Leakage Current	$V_{RRM} = 600V$	-	-	15	mA
I_{DRM}	Max. Peak Off-state Leakage Current	$V_{DRM} = 600V$	-	-	15	mA
V_{TM}	Forward On-state Voltage	$I_F = 100A$	-	-	1.35	V
		$I_F = 50A$	-	-	1.15	
I_H	Holding Current	DC Method, Bias Condition C	-	200	300	mA

Dynamic Characteristics

IGBT						
Symbol	Parameter	Test Conditions	Min	Typ	Max	Units
Q_G	Total Gate Charge	$V_{CC} = 300V$, $I_C = 150A$, $V_{GE} = 15V$	-	-	1600	nC
$t_{d(on)}$	Turn On Delay Time	$V_{CC} = 300V$, $I_C = 150A$	-	-	1200	ns
t_r	Rise Time	$V_{GE1} = V_{GE2} = 15V$	-	-	850	ns
$t_{d(off)}$	Turn Off Delay Time	$R_G = 20\Omega$, Turn-on	-	-	2.1	μs
t_f	Fall Time	$R_G = 10\Omega$, Turn-off	-	-	300	ns

Diode						
Symbol	Parameter	Test Conditions	Min	Typ	Max	Units
t_{rr}	Diode Reverse Recovery Time	$I_E = 150A$, $di/dt = 300A/\mu s$ Min	-	-	170	ns
Q_{rr}	Diode Reverse Recovery Charge	Bridge Diodes only	-	-	9.0	μC

G150SPBK06P3H

International
IRF Rectifier

Circuit Diagram - HiRel™ INT-A-Pak 3

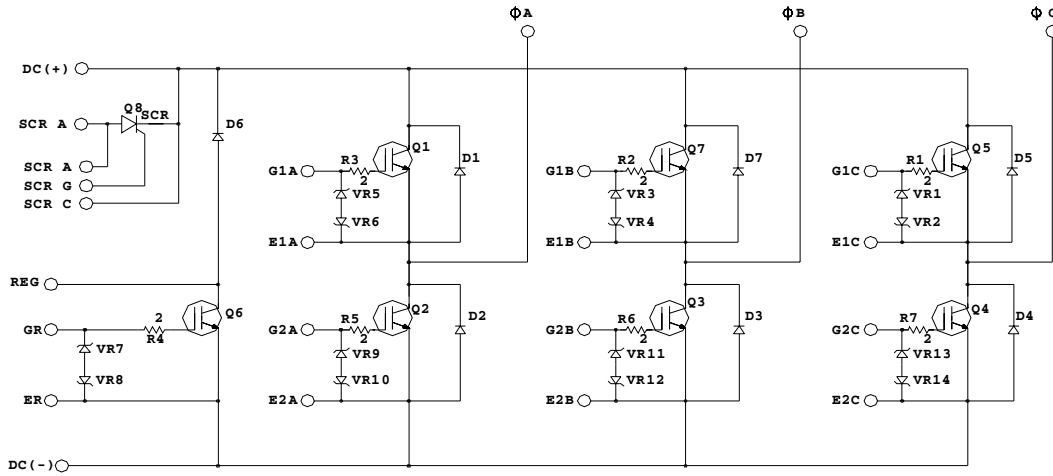

Case Outline- HiRel™ INT-A-Pak 3

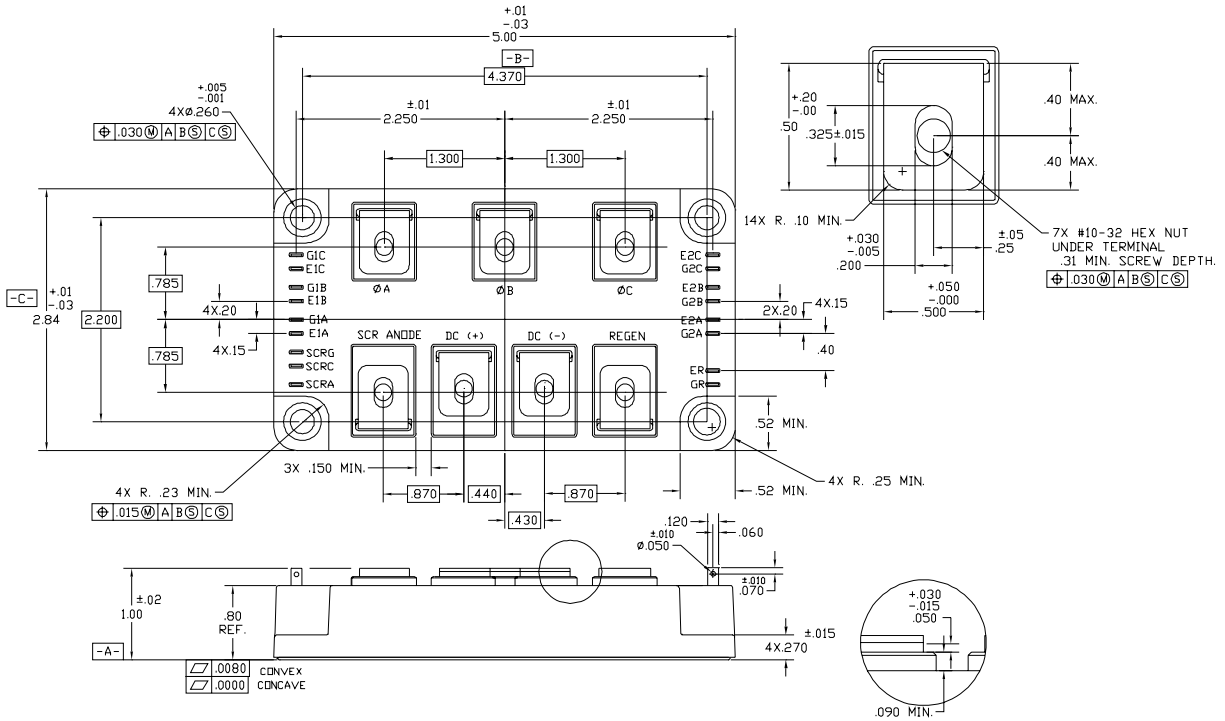

Notes: 1) All dimensions are in inches
 2) Unless otherwise specified,
 Tolerances .XX = ±0.01, .XXX = ±0.005

Part numbering Nomenclature

