

**Closed Loop Speed Controller For
 3-Phase Brushless DC Motor
 MP-3T Package**

OMC506



Description:

The OMC506 is an integrated, high density, three phase Brushless DC (BLDC) motor, speed controller housed in a MP-3T package. The OMC506 contains the power, driver and control electronics to adjust timing functions and speed control loop parameters to optimize the controller for each application. The electronics contained in the OMC506 are assembled using mixed process technologies: surface mount components on a printed circuit board and chip & wire on an Insulated Metal Substrate. This combination offers small size, excellent thermal characteristics and electrically isolated heat sink.

Features:

- 10A Average Phase Output Current
- Compensation Circuitry Adjustable to Motor Parameters
- Speed Controlled by 0 to 5V Linear Input Signal
- Forward or Reverse Direction
- Isolated, Low Profile Package

Absolute Maximum Ratings

Symbol	Parameter		Units
V_M	Motor Supply Voltage	32	Vdc
$V_{M\ pk}$	Peak Motor Supply Voltage	48	V
I_O	Average Phase Output Current	10	A
I_{OP}	Pulsed Output Current (<1% Duty Cycle)	30	
I_{OSC}	Oscillator Input Current (Source or Sink)	30	mA
V_{REF}	Reference Output Voltage ($I_{REF} = 1.0mA$)	6.5	V
	Digital Inputs (Fwd / Enable / Brake / SA /SB / SC)	6.5	
I_{REF}	Reference Output Current ($V_{REF} = 6.2V$)	10	mA
V_{SPEED}	Speed Control Input Voltage	-0.3 to V_{REF}	V
V_{TACH}	Tachometer Input Voltage	-0.3 to V_{REF}	
	Regulator Output Current ($V_{REG} + 15V$)	100	
V_{CS}	Current Sense Input Voltage	-0.3 to 5.0	V
T_{OP}	Operating Temperature Range	-25 to 85	°C

Electrical Characteristics @ T_J = 25°C (Unless Otherwise Specified)

Characteristics	Parameter	Symbol	Min.	Typ.	Max.	Units	Test Conditions
REFERENCE	Reference Output Voltage	V _{REF}	5.9	6.24	6.5	V	I _{REF} = 1.0mA
	Reference Load Current	I _{REF}	-	5.0	8.0	mA	
OSCILLATOR	Oscillator Frequency	F _{OSC}	22	25	28	KHz	
	Sawtooth Peak Voltage	V _{OSCpk}	-	4.1	4.5	V	R _{OSC} = 4.7K,C _{OSC} = 0.01mF
	Sawtooth Valley Voltage	V _{OSCva}	1.2	1.5	-	V	
DIGITAL INPUTS	High Input Treshhold Voltage	V _{ih}	3.0	2.2	-	V	
	Low Input Treshhold Voltage	V _{il}	-	1.7	0.8	V	
CURRENT SENSE	Treshhold Voltage	V _{th}	85	101	115	mV	
	Input Common Mode Volt Range	V _{icr}	-	3.0	-	V	
	Input Bias Current	V _{ib}	-	-0.9	-5.0	mA	
VOLTAGE REGULATOR	Output Voltage	V _{reg}	14	14.5	15	V	
	Load Regulation	I _{reg}	-	0.1	0.3	%	10mA < I _O < 100mA
THERMAL	Internal Current Sense Resistor	R _s	9.5	10	10.5	mOhm	
	Junction-to-Case MOSFET Resist.	R _{thjc}	-	-	1.6	°C/W	

MP3 Package Application

A new mixed signal module fully integrates power, control functions, and drive circuitry into a single 2" x 4" x 0.48" package. The module provides closed loop speed control of three phase, brushless DC (BLDC) motors used in a variety of system applications. The OMC506 has been designed with flexibility in mind. Timing functions and loop parameters can be adjusted to optimize the OMC506 to each customer's application. In addition, the OMC506 has been designed into a MP-3T package. This package uses an insulated metal substrate, thereby, isolating the module's electronics from chassis while providing the necessary thermal interface for proper performance. The OMC506 offers a high efficiency, flexible, compact, motion control system in an industry standard footprint.

Block Diagram

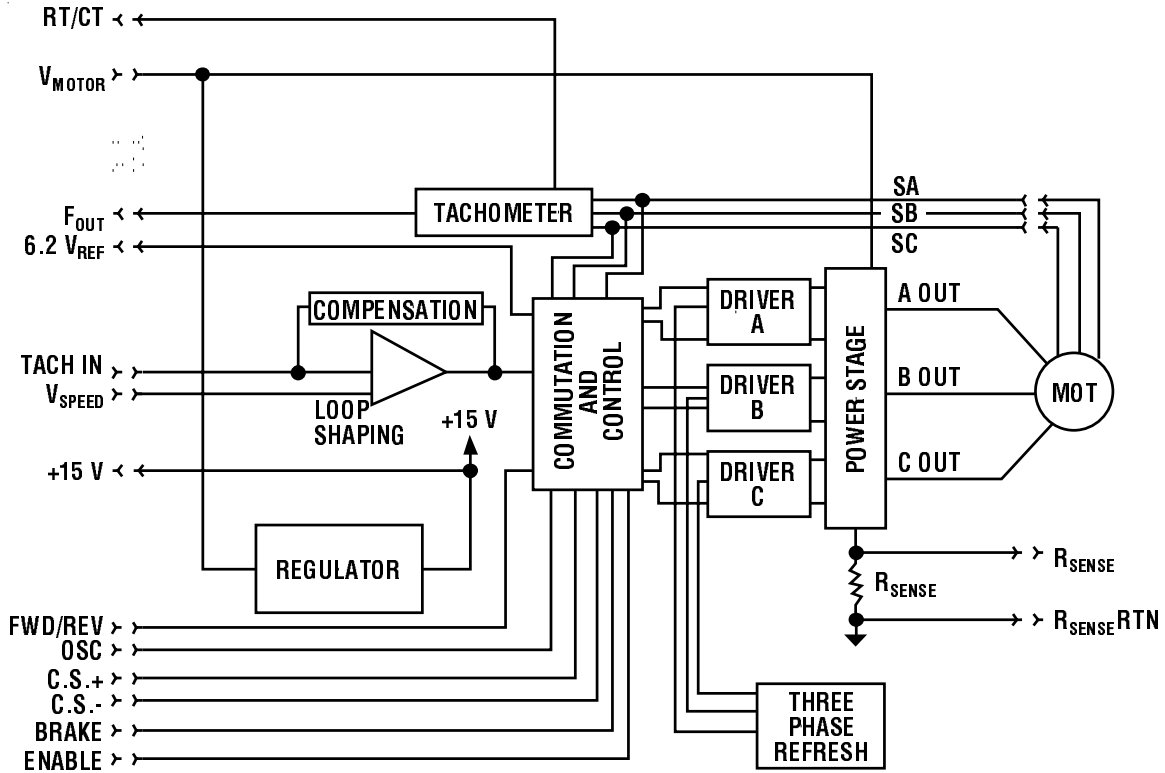

Controller

The OMC506 is based on the Motorola MC33035 Brushless Motor Control I.C. This controller is used in concert with the motorola MC33039 Closed Loop Brushless Motor Adapter I.C. to provide direct duty cycle control of the motor speed. The OMC506 provides two quadrant speed control via an analog 0 to 5V signal applied to the Vspeed (pin22) input. The OMC506 is selected for 60/120 degree hall sensor spacing. The commutation truth table for the OMC506 is shown in Table 1.

Table 1 - Commutation Truth Table

Inputs						Outputs				
120°			F/R	Enable	Brake	A _{OUT}	B _{OUT}	C _{OUT}	Fault	Notes
SA	SB	SC								
1	0	0	1	1	0	1	-	0	1	
1	1	0	1	1	0	-	1	0	1	
0	1	0	1	1	0	0	1	-	1	
0	1	1	1	1	0	0	-	1	1	
0	0	1	1	1	0	0	-	0	1	
1	0	1	1	1	0	1	0	-	1	
1	0	0	0	1	0	0	-	1	1	
1	1	0	0	1	0	-	0	1	1	
0	1	0	0	1	0	1	0	-	1	
0	1	1	0	1	0	1	-	0	1	
0	0	1	0	1	0	-	1	0	1	
1	0	1	0	1	0	0	1	-	1	
1	1	1	X	X	0	-	-	-	0	1
0	0	0	X	X	0	-	-	-	0	
1	1	1	X	X	1	0	0	0	0	1
0	0	X	X	1	1	0	0	0	0	
V	V	V	X	1	1	0	0	0	1	2
V	V	V	X	0	1	0	0	0	0	
V	V	V	X	0	0	-	-	-	0	

Notes:

- 1) Invalid Sensor Inputs; X= Don't Care
- 2) V= Valid Sensor Input

Closed Loop Circuit

Additional amplifiers are used in the OMC506 to provide the necessary control loop compensation for extended bandwidth. By extending the bandwidth of the direct duty cycle control system, torque perturbations can be accounted for while regulating the speed of the motor. This allows the module to be used in relatively dynamic systems as well as constant torque applications. Internally, the compensation circuitry used for control loop shaping can be tuned to optimize the OMC506 for various applications.

The OMC506 provides directional, braking, and enable interfaces from the controller I.C. (pins 32, 24 and 25, respectively). The module also allows the user to externally set the pulse width modulation (PWW) frequency (pin21) as well as the pulse width from the Closed Loop Brushless Motor Adapter (pin 34). This allows a common module to be used in many applications.

Motor commutation and speed control are derived from the Hall effect sensor signals provided from the motor. The signals are provided as inputs to the OMC506 (pins 29, 30 and 31). The amplitude of the sensor signals must be limited, by the user, to +6.2V to insure proper operation of the module.

Finally, the output from the Closed Loop Brushless Motor Adapter is provided as an output of the OMC506. This signal has fixed amplitude and pre-set pulse width. The frequency is six times that of the motor. This signal is integrated to produce a voltage proportional to motor speed.

Current Limit

The OMC506 provides outputs from the internal current sense resistor (pin 7 & 8). These outputs can be directly wired to the C.S. +, C.S.- (pin 28 & 27) inputs. The outputs can also be used in external current limit circuitry. Figure 1 shows a typical connection of the OMC506's current limit circuitry.

Figure 1 - Current Limit Circuitry

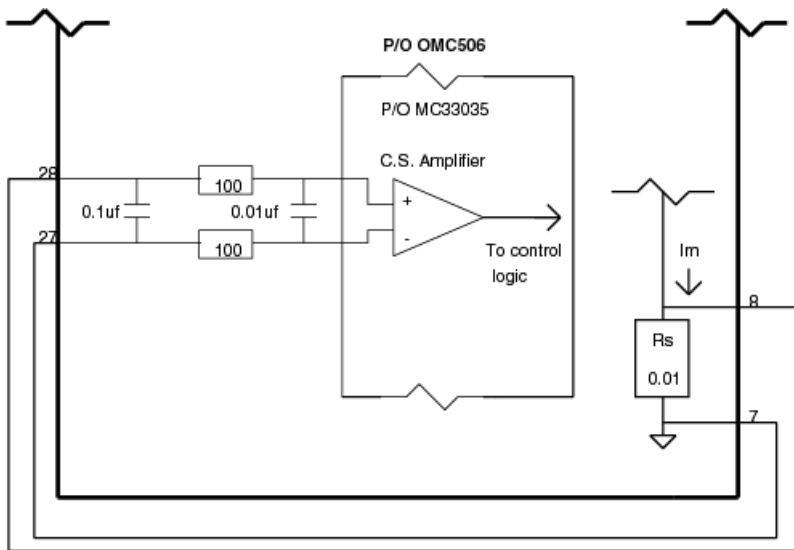

Over Temperature Protection

The Over Temperature Protection circuit function in the OMC506 is disabled. Pin numbers 18 and 19 shall remain floating during Motor Controller Operation.

Typical Motor Connections

Figure 2 shows a typical application of the OMC506. The user must externally connect an electrolytic capacitor (value is dependant on the application) bypassed with a ceramic decoupling capacitor. These capacitors should be as close to the module as feasible. In addition, it is recommended that a transient suppressor also be added in parallel with the external capacitors to prevent high voltage transients on the motor bus.

Figure 2 - Typical Motor Connections

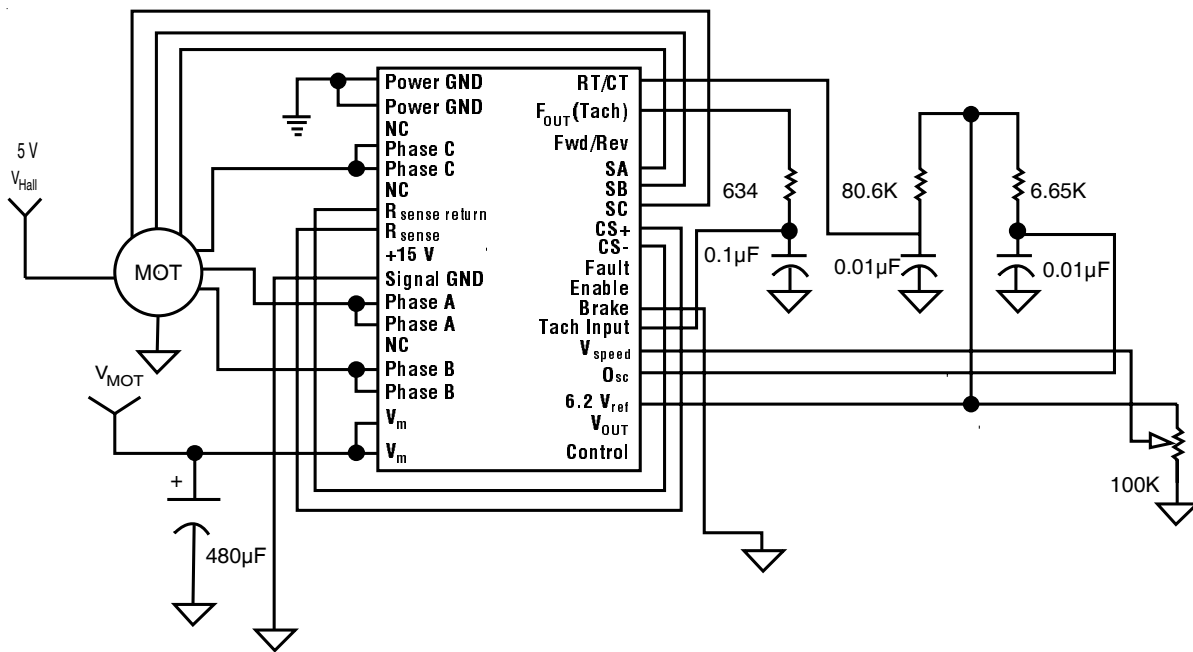

Conclusion

International Rectifier's OMC506 offers a complete motor control system, that is flexible in design, in a high density, high power industrial module. The assembly technology makes the OMC506 an ideal candidate in systems where package size is critical. This power module integrates all the functions necessary to control a DC brushless motor. The design of the OMC506 is flexible enough to be customized for various applications while still maintaining a turn-key solution to the end user. Finally, the MP310, as other industrial packages from International Rectifier, makes the user's mechanical interface simple while optimizing the thermal transfer from the module to the heatsink.

Mechanical Outline - MP-3T

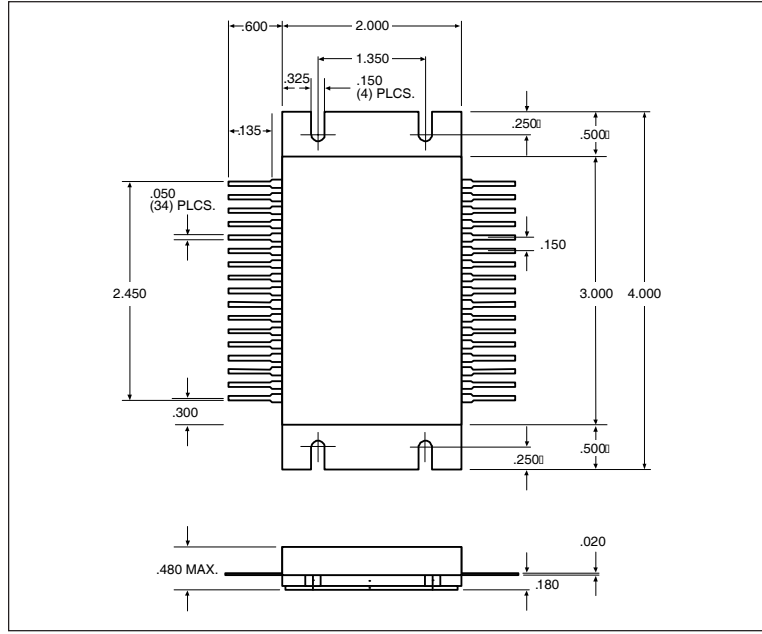

Pin Designation

Pin No.	Designation	Pin No.	Designation	Pin No.	Designation	Pin No.	Designation
1	Power GND	11	Phase A	21	OSC	31	SA
2	Power GND	12	Phase A	22	Vspeed	32	Fwd / Rev
3	N/C	13	N/C	23	Tach Input	33	F _{OUT} (Tach)
4	Phase C	14	Phase B	24	Brake	34	RT / CT
5	Phase C	15	Phase B	25	Enable		
6	N/C	16	V _m	26	Fault		
7	R _{sense} return	17	V _m	27	CS -		
8	R _{sense}	18	N/C	28	CS+		
9	+ 15V	19	N/C	29	SC		
10	Signal GND	20	6.2 V _{REF}	30	SB		

Note: Contact IR Leominster for lead bending options