

## FULL-FEATURED CIRCUIT BOARD ASSEMBLY FOR DIRECT DRIVE OF 3-PHASE BRUSHLESS DC MOTORS

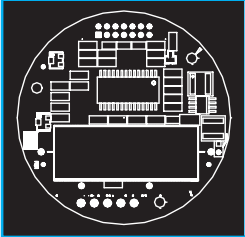

### 5 Amp. Push-Pull 3-Phase Brushless DC Motor Controller/Driver Circuit Board

#### FEATURES

- Fully integrated 3-Phase Brushless DC Motor Control System
- 5A Average Phase Current (10A peak) with 30V Maximum Bus Voltage
- Onboard Current Sense Resistor
- Direction and Torque Control
- Tachometer Output
- Fits Inside Motor Housing

#### APPLICATIONS

- Fans and Pumps
- Hoists
- Actuator Systems

#### DESCRIPTION

The OMC507 is a three phase brushless DC Motor Controller Driver. The OMC507 is a 2 quadrant controller and provides control of motor current (torque) in proportion to the input current command. The versatility of the OMC507 allows the user to either provide an analog or a TTL PWM current command signal externally, or to set an analog current command onboard. The OMC507 also allows the user to adjust the current command offset onboard through the use of a potentiometer. Loop compensation is provided onboard and loop compensation component values can be modified to meet specific customer requirements, thereby optimizing the controller for each application.

The OMC507 controller utilizes surface mount and through hole technology. The OMC507 is a mere 2 1/2 inches in diameter and can fit inside the motor housing. A connector for the control section is optional; consult the factory.

SIMPLIFIED BLOCK DIAGRAM

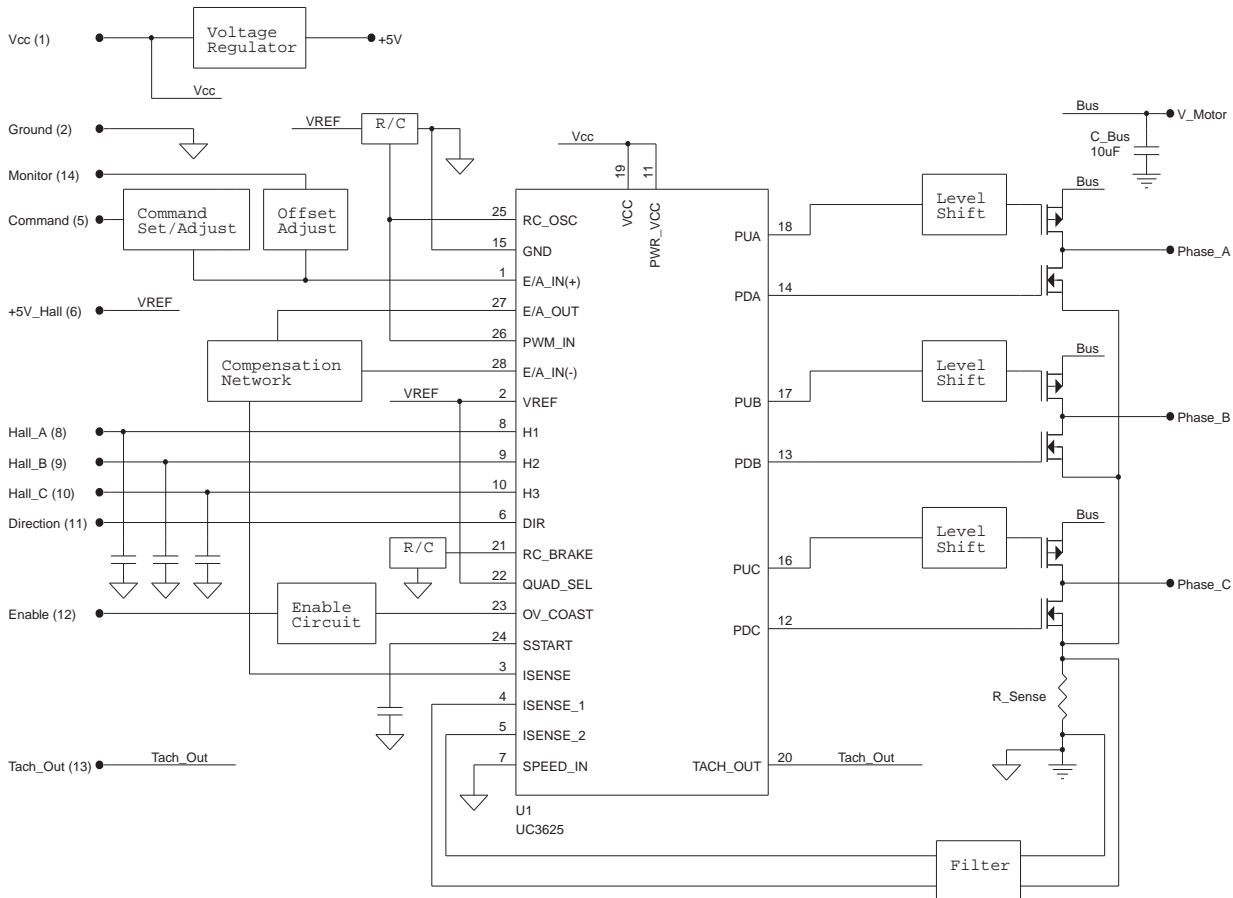

COMMUTATION TRUTH TABLE

This table shows the Phase Output state versus the state of the Hall-Effect and Direction Inputs. Please note that the Hall-Effect Inputs are Grey-encoded; that is, only one input is allowed to change from one input state to another at a time.

The commutation coding shown reflects Hall-Effect sensors that are spaced at 120 mechanical increments. Also, internal protection logic disables all three Phase Outputs when the Hall-Effect Inputs are set to an illegal condition (i.e. all logic low or all logic high).

DIGITAL INPUTS				PHASE OUTPUTS		
Dir	H1	H2	H3	A	B	C
1	0	0	1	Hi-Z	Sirk	Source
1	0	1	1	Sirk	Hi-Z	Source
1	0	1	0	Sirk	Source	Hi-Z
1	1	1	0	Hi-Z	Source	Sirk
1	1	0	0	Source	Hi-Z	Sirk
1	1	0	1	Source	Sirk	Hi-Z
0	1	0	1	Sirk	Source	Hi-Z
0	1	0	0	Sirk	Hi-Z	Source
0	1	1	0	Hi-Z	Sirk	Source
0	0	1	0	Source	Sirk	Hi-Z
0	0	1	1	Source	Hi-Z	Sirk
0	0	0	1	Hi-Z	Source	Sirk
X	0	0	0	Hi-Z	Hi-Z	Hi-Z
X	1	1	1	Hi-Z	Hi-Z	Hi-Z

ABSOLUTE MAXIMUM RATINGS

Motor Supply Voltage, $V_m$ .....	30 Vdc
Peak Motor Supply Voltage $V_{m\text{ PK}}$ .....	50 Vdc
Average Phase Output Current, $I_o$ @ $T_A = +25^\circ\text{C}$ .....	5 Amperes DC
$I_b$ @ $T_A = +85^\circ\text{C}$ .....	3 Amperes DC
Peak Phase Output Current, $I_{o\text{ PK}}$ @ $T_A = +25^\circ\text{C}$ .....	10 Amperes Peak*
Control Supply Voltage, $V_{cc}$ .....	+18 V
Logic Input Voltage (Note 1) .....	-0.3 V to +6 V
Reference Source Current .....	-30 mAdc
Command Input Voltage Range, .....	-0.3 V to +6 V
Current Sense Amplifier Input Voltage (ISH/ISL) .....	-0.3 V to +6 Vdc
Tachometer Output Current .....	$\pm 10$ mAdc
Operating Ambient Temperature .....	$0^\circ\text{C}$ to $+85^\circ\text{C}$
Operating Junction Temperature .....	$0^\circ\text{C}$ to $+120^\circ\text{C}$
Storage Temperature Range .....	$-20^\circ\text{C}$ to $+120^\circ\text{C}$
Power Switch Junction-to-Ambient Thermal Resistance, $R_{\theta\text{JA}}$ .....	$62.5^\circ\text{C/W}$

\*Maximum pulse width = 10 Sec

RECOMMENDED OPERATING CONDITIONS ( $T_A = 25^\circ\text{C}$ )

Motor Power Supply Voltage, $V_m$ .....	+28 Vdc
Average Phase Output Current, $I_o$ (Note 2) .....	5 A
Control Supply Voltage, $V_{cc}$ .....	15Vdc $\pm 10\%$
Logic Low Input Voltage, $V_{il}$ .....	0.8 Vdc (max)
Logic High Input Voltage, $V_{ih}$ .....	2.0 Vdc (min)

Note 1: Logic Inputs: Direction, Hall Inputs (Hall\_A...Hall\_C), and Enable.

Note 2: Onboard current sense resistor; 20 m (nominal), 2W.

## ELECTRICAL CHARACTERISTICS (Note 1)

OMC507

Parameter	Symbol	Conditions (Note 1)	MIN.	TYP.	MAX.	Units
<b>Power Output Section</b>						
Zero Gate Voltage Drain Current	$I_{DSS}$	(N-CH) $V_{DS} = 60V_{DC}$ $V_{GS} = 0V$ (P-CH) $V_{DS} = -60V_{DC}$ $V_{GS} = 0V$			1	$\mu A$
					-1	$\mu A$
Drain-to-Source On-Resistance	$R_{DS(on)}$	(N-CH) $I_D = 30A$ $V_{GS} = 10V$ (Note 2) (P-CH) $I_D = -30A$ $V_{GS} = -10V$ (Note 2)			0.008	Ohms
					0.020	Ohms
Gate Body Leakage Current	$I_{GBS}$	$V_{GS} = \pm 20V_{DC}$ $V_{DS} = 0V$			$\pm 100$	nA
Diode Forward Voltage	$V_{SD}$	(N-CH) $I_F = 30A$ (Note 2) $V_{GS} = 0V$ (P-CH) $I_F = -30A$ $V_{GS} = 0V$			0.9	V
					-1.0	V
Diode Reverse Recovery Time	$t_r$	(N-CH) $I_F = 75A$ , $di/dt = 100A/\mu sec$ , $V_{GS} = 0V$ (P-CH) $I_F = -65A$ , $di/dt = 100A/\mu sec$ , $V_{GS} = 0V$			120	nSec
					120	nSec
<b>Control Section</b>						
Control Supply Current	$I_{CC}$	$T_C$ over operating range			100	m A
Control Turn-On Threshold	$V_{OC(+)}$	$T_C$ over operating range	9.45			V
<b>Reference Section</b>						
Output Voltage	$V_{REF}$		4.9	5.0	5.1	V
Output Current	$I_D$				30	m A
<b>Current-Sense Amplifier Section</b>						
Peak Current Threshold Voltage	$V_{PK}$	$V(\text{pin } 12) = 0V$ , $V(\text{pin } 13)$ Varied to Threshold	0.14	0.20	0.26	V
Over Current Threshold Voltage	$V_{OC}$	$V(\text{pin } 12) = 0V$ , $V(\text{pin } 13)$ Varied to Threshold	0.26	0.30	0.36	V
Amplifier Voltage Gain	$A_V$	$V(\text{pin } 12) = 0.3V$ , $V(\text{pin } 13)$ $= 0.5V$ to $0.7V$	1.75	1.95	2.15	V/V
Amplifier Level Shift	-	$V(\text{pin } 12) = V(\text{pin } 13) = 0.3V$	2.4	2.5	2.65	V
<b>Logic Input Section</b>						
H1, H2, H3 Low Voltage Threshold	$V_L$	$T_C$ over operating range	0.8	1.0	1.2	V
H1, H2, H3 High Voltage Threshold	$V_H$	$T_C$ over operating range	1.6	1.9	2.0	V
H1, H2, H3 Input Current	$I_{IH}$	$T_C$ over operating range, $V(\text{pin } 8, 9 \text{ or } 10) = 0V_{DC}$	-400	-250	-120	$\mu A$
Direction Threshold Voltage	$V_{TH}$	$T_C$ over operating range	0.8	1.4	2.0	V
Direction Voltage Hysteresis	$V_H$			0.6		V
Direction Input Current	$I_{IH}$		-30	-1	30	$\mu A$
<b>Enable Input Section</b>						
Enable Threshold Voltage	$V_{TH}$			2.0		V
Enable Input Current	$I_{IH}$			100		$\mu A$

OMC507

Parameter	Symbol	Conditions (Note 1)	MIN.	TYP.	MAX.	Units
<b>Command Input Section</b>						
Command Input Voltage Range	V <sub>CM</sub>		0		5	V
<b>Tachometer/Brake Section</b>						
Tachometer Output High Level	V <sub>oh</sub>	T <sub>c</sub> over operating range	4.7	5.0	5.3	V
Tachometer Output Low Level	V <sub>ol</sub>	T <sub>c</sub> over operating range			0.2	V
Tachometer On-Time	t <sub>on</sub>		85	100	140	us
Tachometer On-Time Variation	-	T <sub>c</sub> over operating range		0.1		%
<b>Oscillator Section</b>						
Oscillator Frequency	f <sub>o</sub>			10.5		kHz

SPECIFICATION NOTES:

1. All parameters specified for T<sub>a</sub> = 25 C, V<sub>CC</sub> = 15Vdc, and all Phase Outputs unloaded (T<sub>a</sub> ~ T<sub>j</sub>). All negative currents shown are sourced by (flow from) the pin under test.
2. Pulse Test: Pulse width ≤ 300 μsec, duty cycle ≤ 2%.

PINOUT

PIN#	NAME
J1-1	VCC
J1-2	Ground
J1-3	N/C
J1-4	N/C
J1-5	Command
J1-6	+5V_Hall
J1-7	Hall_Rtn
J1-8	Hall_A
J1-9	Hall_B
J1-10	Hall_C
J1-11	Direction
J1-12	Enable
J1-13	Tach_Out
J1-14	Offset_Mon
T1	V_Motor
T2	Motor_Rtn
T3	Phase_A
T4	Phase_B
T5	Phase_C

## PIN DESCRIPTIONS / FUNCTIONALITY

VCC (Pin 1) -- The Vcc Supply input provides bias voltage to all of the internal control electronics within the OMC507, and should be connected to a nominal +15Vdc power source.

GROUND (Pin 2) -- The voltages that control the OMC507 are referenced with respect to this pin.

COMMAND (Pin 5) -- This input is the current command input to the OMC507. For other command configurations, consult the factory for proper termination of this pin.

+5V\_Hall (Pin 6) -- This output provides a temperature-compensated, regulated +5V reference to power the external Hall-effect motor position sensors. By design, the +5V reference must be in regulation before the remainder of the control circuitry is activated. This feature allows the Hall-effect sensors to become powered and enabled before any Phase Output is enabled in the OMC507, preventing damage at turn-on.

HALL\_RETURN (Pin 7) -- This pin is connected to Ground onboard and is used as the +5V Hall return.

HALL\_EFFECT INPUTS (Hall\_A, Pin 8; Hall\_B, Pin 9; Hall\_C, Pin 10) -- Each input has an internal pull-up resistor to the +5V reference. Each input also has an internal 2200pF noise filter capacitor to Ground. Motors with 60 degree position sensing may be used if one or two of the Hall-Effect sensor signals is inverted prior to connection to the Hall-Effect Inputs.

DIRECTION INPUT (Pin 11) - This input is used to select the motor direction. This input has an internal protection feature: the logic-level present on the Direction Input is first loaded into a direction latch, then shifted through a two-bit shift register before interfacing with the internal output phase driver logic decoder. Also, protection circuitry detects when the input and the output of the direction latch or the 2-bit shift register are different, and inhibits the Phase Outputs (i.e. Hi-Z) during those times. This feature may be used to allow the motor to coast to a safe speed before a direction reversal takes place. Power stage cross-conduction (current "shoot-through" from Vmotor to Ground through simultaneously enabled pull-up and pull-down drivers) is prevented by the shift register as it is clocked by the PWM oscillator, so that a fixed delay of between one and two PWM oscillator clock cycles occurs. This delay or "dead-time" guarantees that power-stage cross-conduction will not occur.

ENABLE INPUT (Pin 12) -- This input is the enable/disable input to the OMC507.

TACHOMETER OUTPUT (Pin 13) -- This output provides a fixed width 5V pulse when any Hall-Effect Input (1, 2 or 3) changes state. The pulse width of the Tachometer Output is set to 150ms (nominal). The average value of the output voltage on pin 13 is directly proportional to the motor's speed.

OFFSET MONITOR (Pin 14) -- This pin is used to monitor the offset adjust voltage, set at RPL, to accommodate the current sense amplifier offset, approximately 2.5 volts.

V\_MOTOR (T1) - This terminal is connected to the most positive terminal of the motor supply (Vm+).

MOTOR RETURN (T2) - This terminal is connected to the most negative terminal of the motor supply (Vm-).

PHASE OUTPUTS (Phase, A T3; Phase B, T4; Phase C, T5) -- These outputs are connected to either Vmotor via the pull-up driver or Sense via the pull-down driver, depending upon the Hall-Effect and Direction Inputs (see Commutation Truth Table). The terminals associated with each Phase Output must be connected to one of the three phases of the motor driven by the OMC507.

## APPLICATION NOTE

## Setup

The OMC507 is a current mode controller providing control of motor current (torque) in proportion to a current command; Figure 1 is representative of the OMC507 configured as a current mode controller.

The OMC507 Motor Controller offers the user versatility in both system performance and interface.

For example, the typical configuration of the OMC507 requires the user to provide an analog current command signal (voltage) proportional to the motor current— a 1 volt command is proportional to 1.2 amperes of motor current; the OMC507 can also be configured such that the user provides a TTL PWM input command or the analog current command signal is set onboard. Consult the factory for details.

Also, the typical configuration of the OMC507 requires the user to interface to the control and power sections of the controller via wire solder terminations— the control section will accommodate #22 AWG wire and the power section will accommodate #18 AWG wire; the OMC507 can also be configured to provide the user with a connector solution for the control section. Consult the factory for details.

## Operation

The typical configuration of the OMC507 incorporates a 0.020 ohm resistor to sense the motor current—  $V_{sense} = I_{motor} \times R_{sense}$ . The sense voltage— current sense signal—is filtered and fed into the current sense amplifier where the absolute value of the signal is multiplied by two and biased up by approximately 2.5 volts (Note: Adjust the offset adjust potentiometer (RP1) onboard to accommodate the current sense amplifier offset; the Command input (location J1-5) must be grounded. Monitor the offset adjust voltage at location J1-14).

Besides the implementation of the cycle-by-cycle peak current limit/overcurrent limit protection feature of the OMC507, the output of the current sense amplifier is fed into the error amplifier which is configured as a differential amplifier. An error signal representing the difference between the current command input and the value of the amplified current sense signal is produced; the error signal is then compared to a pulse width modulated (PWM) ramp. And since torque is nearly proportional to the average phase output current, the torque is controlled via duty cycle control.

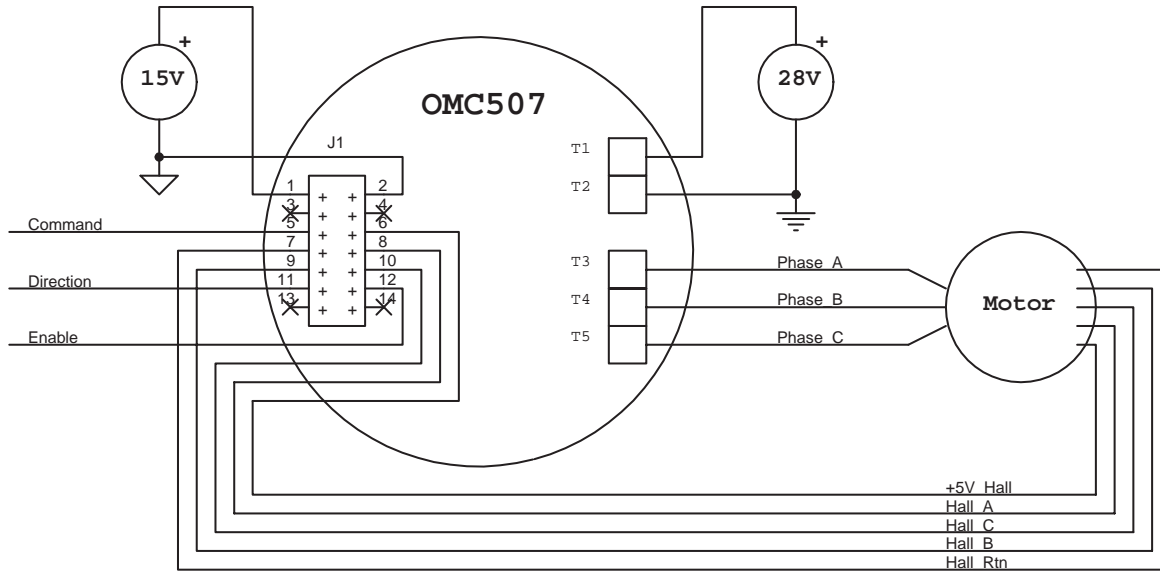
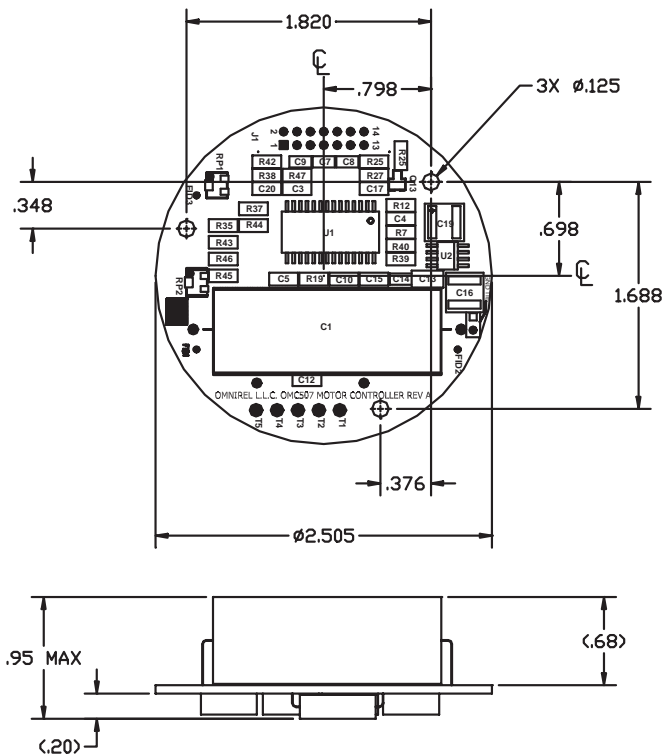

Figure 1: Current Mode Controller



NOTES:

1. NOMINAL THICKNESS OF PRINTED CIRCUIT BOARD: .062 THK.

Figure 2: Mechanical Outline