

1.5 AMP NEGATIVE ADJUSTABLE VOLTAGE REGULATOR APPROVED TO DESC DRAWING 7703403



Three Terminal, Precision Adjustable Negative Voltage Regulator In Hermetic Style Packages (LM137)

FEATURES

- Similar To Industry Standard LM137
- Approved To DESC Standardized Military Drawing Number 7703403
- Built In Thermal Overload Protection
- Short Circuit Current Limiting
- Available In Six Package Styles

DESCRIPTION

These three terminal negative regulators are supplied in hermetically sealed packages. All protective features are designed into the circuit, including thermal shutdown, current-limiting, and safe-area control. With heat sinking, these devices can deliver up to 1.5 amps of output current. The LCC-20 device is limited to .5 amps. The unit also features output voltages that can be fixed from -1.2 volts to -37 volts using external resistors.

ABSOLUTE MAXIMUM RATINGS $T_c @ 25^\circ\text{C}$

Power Dissipation

Case 2	1.1 W
Case-All Others.	20 W
Input - Output Voltage Differential	40 V
Operating Junction Temperature Range	- 55°C to + 150°C
Storage Temperature Range	- 65°C to + 150°C
Lead Temperature (Soldering 10 seconds)	300°C
Thermal Resistance, Junction to Case:	
Case 2, LCC-20	17°C/W
Case U & M, TO-257 (Isol) and SMD-3	4.2°C/W
Case T&N, TO-257 (Non-Isol) and SMD-1	3.5°C/W
Case Y, TO-3	3.0°C/W

Maximum Output Current:

Case 25 A
Case-All Others.	1.5A

Recommended Operating Conditions:

Output Voltage Range	-1.2 to -37 VDC
Ambient Operating Temperature Range (T_A)	- 55°C to + 125°C
Input Voltage Range	-4.25 to -41.25 VDC

3.5



ELECTRICAL CHARACTERISTICS -55°C T_A 125°C, $I_L = 8mA$ (unless otherwise specified)

OM1322NTM, OM1322STM, OM1322NKM, OM1322SMM, OM1322NMM

Parameter	Symbol	Test Conditions	Min.	Max.	Unit
Reference Voltage	V_{REF}	$ V_{DIFF} = 3.0V, T_A = 25^\circ C$ $ V_{DIFF} = 3.0V$ $ V_{DIFF} = 40V, T_A = 25^\circ C$ $ V_{DIFF} = 40V$	-1.275 -1.30 -1.275 -1.30	-1.225 -1.20 -1.225 -1.20	V
Line Regulation (Note 1)	R_{LINE}	3.0 V $ V_{DIFF} $ 40V, $T_A = 25^\circ C$ 3.0 V $ V_{DIFF} $ 40V	-9 -23	9 23	mV
Load Regulation (Note 1)	R_{LOAD}	$ V_{DIFF} = 5.0V, 8mA$ I_L 1.5A $ V_{DIFF} = 12V, 8mA$ I_L 1.5A, $T_A = 25^\circ C$ $ V_{DIFF} = 40V, 8mA$ I_L 200mA, $T_A = 25^\circ C$ $ V_{DIFF} = 40V, 8mA$ I_L 100mA	-25 -25 -25 -25	25 25 25 25	mV
Thermal Regulation	V_{RTH}	$V_{in} = -14.6V, I_L = 1.5A$ $P_d = 20$ Watts, $t = 10$ ms, $T_A = 25^\circ C$	-5	5	mV
Ripple Rejection (Note 2)	R_N	$f = 120$ Hz, $V_{out} = V_{ref}$ $C_{Adj} = 10$ μF	66		dB
Adjustment Pin Current	I_{Adj}	$ V_{DIFF} = 3.0V$ $ V_{DIFF} = 40V$		100 100	μA
Adjustment Pin Current Change	I_{Adj} (Line) I_{Adj} (Load)	3.0V $ V_{DIFF} $ 40V $ V_{DIFF} = 5V, 8mA$ I_L 1.5A	-5 -5	5 5	μA
Minimum Load Current	I_{Lmin}	$ V_{DIFF} = 3.0V, V_{out} = -1.4V$ (forced) $ V_{DIFF} = 10V, V_{out} = -1.4V$ (forced) $ V_{DIFF} = 40V, V_{out} = -1.4V$ (forced)		3.0 3.0 5.0	mA
Current Limit (Note 2)	I_{CL}	$ V_{DIFF} $ 5V $ V_{DIFF} = 40V, T_A = 25^\circ C$	1.5 0.24	3.5 1.2	A

Notes:

1. Load and Line Regulation are specified at a constant junction temperature. Pulse testing with low duty cycle is used. Changes in output voltage due to heating effects must be taken into account separately.
2. If not tested, shall be guaranteed to the specified limits.
3. The • denotes the specifications which apply over the full operating temperature range.

3.5

PART NUMBER DESIGNATOR		
Standard Military Drawing Number	Omnirel Part Number	Omnirel Package Designation
7703403M 7703403U 7703403T 7703403Y 7703403N 7703403Z	OM1322SMM OM1322STM OM1322NTM OM1322 NKM OM1322NMM OM1322N2M	SMD-3 TO-257 (Isolated) TO-257 (non-Isolated) TO-3 SMD-1 LCC-20



ELECTRICAL CHARACTERISTICS -55°C T_A 125°C, $I_L = 8\text{mA}$ (unless otherwise specified)

OM1322N2M

Parameter	Symbol	Test Conditions	Min.	Max.	Unit
Reference Voltage	V_{REF}	$ V_{DIFF} = 3.0\text{V}, T_A = 25^\circ\text{C}$ $ V_{DIFF} = 3.0\text{V}$ $ V_{DIFF} = 40\text{V}, T_A = 25^\circ\text{C}$ $ V_{DIFF} = 40\text{V}$	-1.275 -1.30 -1.275 -1.30	-1.225 -1.20 -1.225 -1.20	V
Line Regulation (Note 1)	R_{LINE}	$3.0\text{V } V_{DIFF} 40\text{V}, T_A = 25^\circ\text{C}$ $3.0\text{V } V_{DIFF} 40\text{V}$	-9 -23	9 23	mV
Load Regulation (Note 1)	R_{LOAD}	$ V_{DIFF} = 5.0\text{V}, 8\text{mA } I_L 200\text{mA}$ $ V_{DIFF} = 15\text{V}, 8\text{mA } I_L 200\text{mA}, T_A = 25^\circ\text{C}$ $ V_{DIFF} = 40\text{V}, 8\text{mA } I_L 150\text{mA}, T_A = 25^\circ\text{C}$ $ V_{DIFF} = 40\text{V}, 8\text{mA } I_L 50\text{mA}$	-25 -25 -25 -25	25 25 25 25	mV
Thermal Regulation	V_{RTH}	$V_{in} = -16.25\text{V}, I_L = 330\text{mA}$ $P_d = 5\text{ Watts}, t = 10\text{ ms}, T_A = 25^\circ\text{C}$	-5	5	mV
Ripple Rejection (Note 2)	R_N	$f = 120\text{ Hz}, V_{out} = V_{ref}$ $C_{Adj} = 10\text{ }\mu\text{F}$	66		dB
Adjustment Pin Current	I_{Adj}	$ V_{DIFF} = 3.0\text{V}$ $ V_{DIFF} = 40\text{V}$		100 100	μA
Adjustment Pin Current Change	I_{Adj} (Line) I_{Adj} (Load)	$3.0\text{V } V_{DIFF} 40\text{V}$ $ V_{DIFF} = 5\text{V}, 8\text{mA } I_L 500\text{ mA}$	-5 -5	5 5	μA
Minimum Load Current	I_{Lmin}	$ V_{DIFF} = 3.0\text{V}, V_{out} = -1.4\text{V (forced)}$ $ V_{DIFF} = 10\text{V}, V_{out} = -1.4\text{V (forced)}$ $ V_{DIFF} = 40\text{V}, V_{out} = -1.4\text{V (forced)}$		3.0 3.0 5.0	mA
Current Limit (Note 2)	I_{CL}	$ V_{DIFF} 5\text{V}$ $ V_{DIFF} = 40\text{V}, T_A = 25^\circ\text{C}$	0.5 0.15	1.8 0.65	A

Notes:

1. Load and Line Regulation are specified at a constant junction temperature. Pulse testing with low duty cycle is used. Changes in output voltage due to heating effects must be taken into account separately.
2. If not tested, shall be guaranteed to the specified limits.
3. The • denotes the specifications which apply over the full operating temperature range.

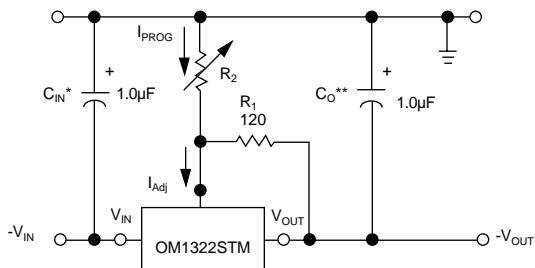

* C_{in} is required if regulator is located more than 4 inches from power supply filter. A 1 μF solid tantalum or 10 μF aluminum electrolytic is recommended.

** C_o is necessary for stability. A 1 μF solid tantalum or 10 μF aluminum electrolytic is recommended.

$$V_{out} = -1.25\text{ V} \left(1 + \frac{R_2}{R_1} \right)$$

3.5

MECHANICAL OUTLINE

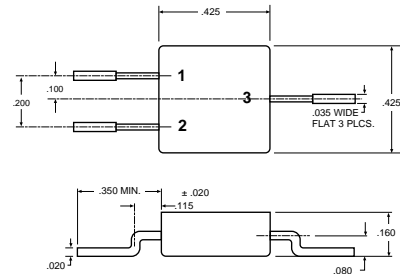
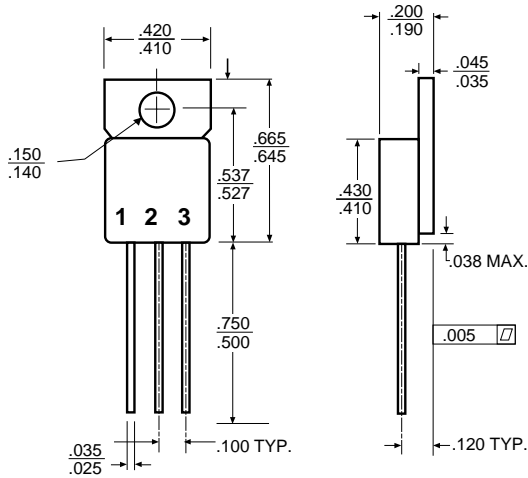

OM1322SMM

Front View
 Pin 1 - Adjust
 Pin 2 - Output
 Pin 3 - Input
 Case - Isolated

OM1322STM

Isolated
 Front View
 Pin 1 - Adjust
 Pin 2 - Input
 Pin 3 - Output
 Tab - Isolated

OM1322NTM

Non-Isolated
 Front View
 Pin 1 - Adjust
 Pin 2 - Input
 Pin 3 - Output
 Tab - Input

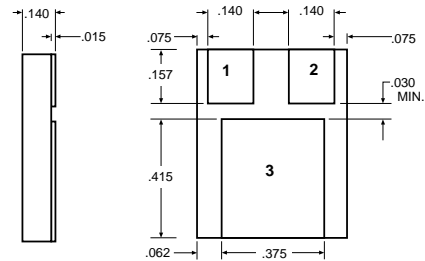

OM1322NMM

Pin 1 - Adjust
 Pin 2 - Output
 Pin 3 - Input

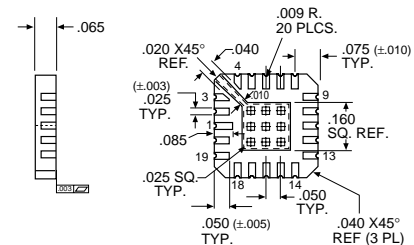
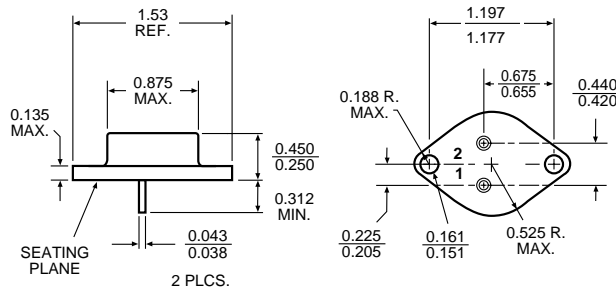

OM1322N2M

Pin 1	V _{OUT}	Pin 11	V _{IN}
Pin 2	V _{OUT} (Sense)	Pin 12	NC
Pin 3	NC	Pin 13	NC
Pin 4	NC	Pin 14	NC
Pin 5	NC	Pin 15	NC
Pin 6	NC	Pin 16	ADJUST
Pin 7	NC	Pin 17	NC
Pin 8	NC	Pin 18	NC
Pin 9	NC	Pin 19	NC
Pin 10	NC	Pin 20	NC

OM1322NKM

Pin 1 - Adjust
 Pin 2 - Output
 Case - Input

For additional information please see the mechanical outline section.

