

IRPLCFL3

International  
**IR** Rectifier

REFERENCE DESIGN

IRPLCFL3 rev.b

International Rectifier • 233 Kansas Street, El Segundo, CA 90245 USA

## IRPLCFL3: A ballast that can be dimmed from a domestic (phase cut) dimmer

*By Peter Green*

### TOPICS COVERED

*Introduction*

*Dimmer Circuit*

*Proposed Solution*

*Block Diagram*

*Functional Description*

*Schematic Diagram*

*Design Considerations*

*Bill of Materials*



IR2156



IRPLCFL3

### INTRODUCTION

It has often been a disadvantage with electronic ballasts that they have been unable to be dimmed with a standard (phase cut) type of dimmer, particularly in the case of small integral ballast-lamp combinations commonly used in the home to save energy. This is due to the fact that, where there is no power factor correction, the ballast circuit input consists of a rectification stage followed by a large storage capacitor connected to the AC mains supply that provides the DC bus from which the high frequency half bridge and output section is supplied. In such a system current is drawn from the mains only near the peak of the mains voltage where the storage capacitor charges and not during the remainder of the mains half-cycle.

Virtually all domestic and professional dimming systems are based on *triacs*. These devices will conduct once they have been fired, only while current flows in excess of the *holding current* of the device. These dimmers work very well with a *resistive* load such as an ordinary Tungsten filament light bulb as the triac can be fired at any point during the mains half-cycle and will continue to conduct until very close to the end of the half-cycle as current is drawn continuously over this period. In this way the lamp current can be adjusted from maximum to zero.

## A BASIC 120VAC DIMMER CIRCUIT

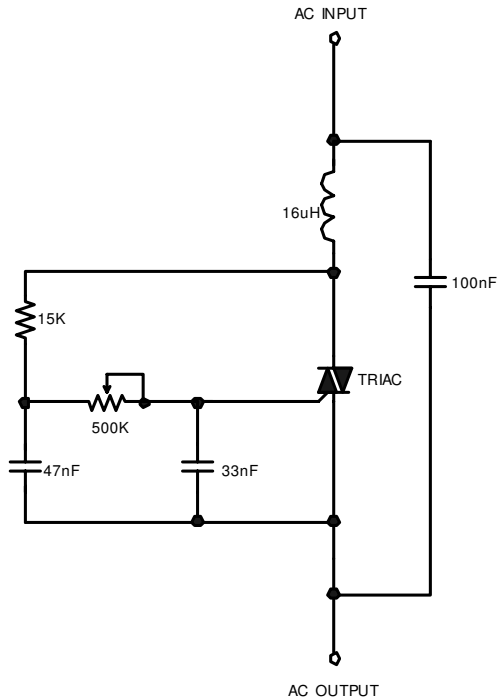

When a compact ballast is connected to a circuit containing such a dimmer, the triac will only conduct if it is fired at a point during the mains half-cycle where the rectified mains voltage is greater than the storage capacitor voltage. In this instance the capacitor will be charged to the same voltage and the triac will then switch off. In this way it would be possible to adjust the DC bus voltage of the ballast to some extent by adjusting the triac firing point from  $90^\circ$  to  $180^\circ$  however this will not provide a satisfactory means of controlling the light output.

There is also an additional problem encountered due to the fact that a dimmer of this kind requires an inductor in series with the triac to limit the rise time of the current when the device is fired. Without this inductor, mains current harmonics would be produced at frequencies high enough to cause considerable radiated and conducted interference problems. Since the load presented by a ballast circuit is effectively capacitive, when the triac is fired there will be *ringing* caused by the resonance of the suppression inductor of the dimmer and the capacitive load. This can cause the triac to fire and then switch off as the ringing output voltage swings above and then below the input voltage causing the current to fall below the holding current. This can occur several times during each half cycle, resulting in severe lamp flicker and loss of control of the output.

## PROPOSED SOLUTION

A system has now been developed, based around the IR2156, where the ballast is able to operate with minimal flicker over a considerable portion of the adjustment range of a dimmer and the light output may be controlled over this range from maximum output down to around 10%.

### IRPLCFL3

In this system the front end of the ballast has been designed so that when the triac in the dimmer has fired, it will remain on continuously until almost the end of the mains half-cycle. In addition to this there is circuitry that detects the firing angle of the triac and adjusts the lamp current by increasing the switching frequency hence the controlling light output depending on the level set by the dimmer.

It should be noted that if the dimmer is set too low the triac will never fire when a capacitive load is connected and also when the ballast is running and the dimmer is turned too low there will be insufficient bus voltage for the ballast to be able to operate. Because of these factors it is impossible for the ballast to operate over the complete range of adjustment of the dimmer. There will also be some hysteresis so when the ballast is being dimmed down and reaches the point where the lamp goes out, the dimmer has to be turned back up some way before the lamp will strike again.

### BLOCK DIAGRAM

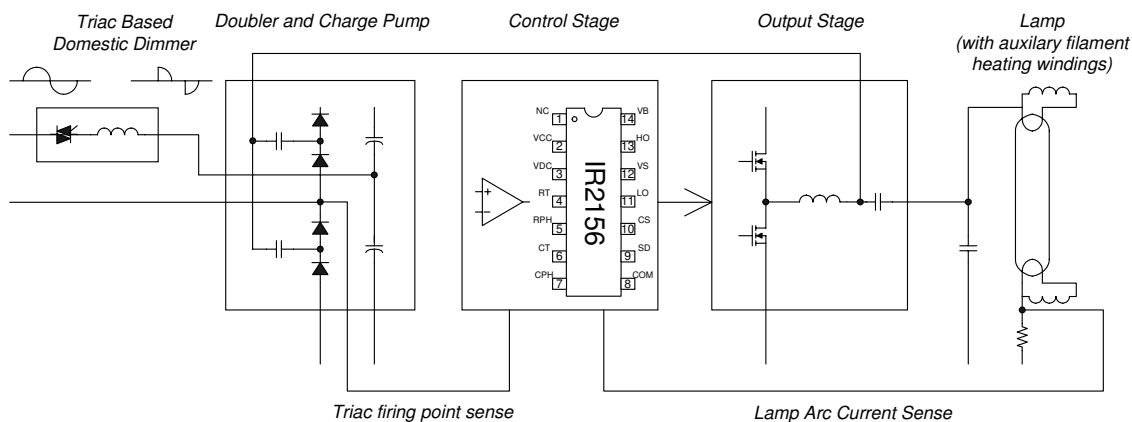

### FUNCTIONAL DESCRIPTION

When the dimmer triac is fired the current that flows must remain above the holding current until a point close to the end of the mains half cycle at which the voltage is very low. This is achieved by ensuring that the ballast draws current exceeding the holding current of a standard power triac as used in most dimmers with a *charge pump* circuit consisting of C5 and C6 in conjunction with D1 to D4 (not to be confused with the charge pump that supplies the Vcc). When the ballast is operating the point between L2 and C15 swings low when Q2 is on, this charges C5 through D2 during the positive half-cycle of the mains voltage. When Q2 switches off and Q1 switches on the voltage between L2 and C15 swings high causing C6 to be discharged through D1 into the storage capacitor C3. During the negative half-cycle of the mains voltage, the opposite happens with C6 and C4. The result is that a continuous series of current pulses are drawn from the input during the period when the triac has been fired until close to the end of the mains half-cycle. The inductor L1 ensures that a continuous current is drawn from the input and that the triac does not switch off between pulses. In order to do this the inductor must store energy when current is being drawn via the charge pump and release this energy during the period when C5 or C6 is discharging. When the ballast is dimmed the frequency increases and so the current in C5 or C6 also increases, ensuring that there will be sufficient to keep the triac switched at all dim levels.

### IRPLCFL3

A *snubber* has also been included consisting of C2 and R2. The purpose of this is to reduce ringing caused by the resonance of the series inductors and load capacitances when the dimmer triac fires. R1 is also essential in achieving this and it is important to select L1 such that it has a DC resistance of about 5 Ohms to provide additional damping. If the series resistance is too low the ballast will not be stable at low dimming levels.

### SCHEMATIC DIAGRAM

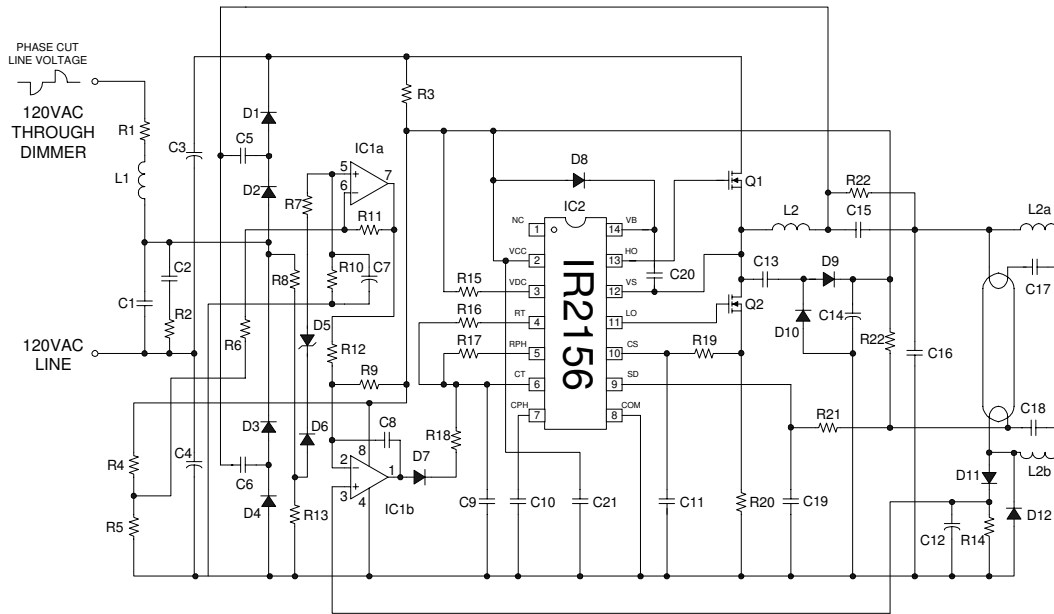

### Phase Cut Voltage and Current

Voltage at Ballast Input

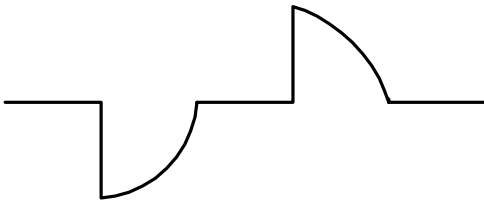

Current at Ballast Input

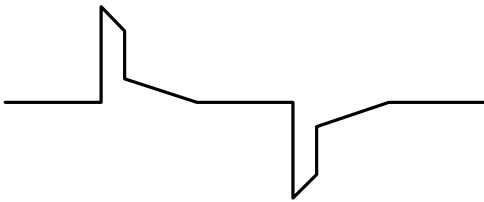

### IRPLCFL3

The voltage waveform at the junction of D2 and D3, ignoring high frequency components is equivalent to the output voltage of the dimmer. With respect to the negative rail of the bus this will be a phase cut approximate sine wave with a DC offset such that the negative peak is at 0V. This is reduced by the voltage divider network of R8 and R13 which is then fed into D6 and D15. Only the signal representing the positive half-cycle of the mains is left at the anode of D5 which is then converted to a DC level via the filter network of R7, R10 and C10. Because the minimum dimming level occurs at a point where the dimmer is still capable of providing enough output for the ballast to operate, this voltage will never actually be zero. Also when the dimmer is at maximum this voltage will only be approximately 3 times the level at minimum dimming level. Since we require a reference voltage to control the lamp current in a closed loop system it is clear that this would only allow dimming down to one third of the lamp current which is not sufficient range. For this reason an offset stage has been added. The inverting input of op amp IC1a is connected to a reference voltage determined by R4 and R5 divided down from the IC supply voltage which is clamped at around 15.6V by the IR2156. The gain is positive and set by the ratio of R11 and R6.

If the voltage at the non-inverting input is  $V_{in}$  and the voltage at the junction of R4 and R5 is  $V_{ref}$ , then  $V_{out}$  will be;

$$(1 + R_{11}/R_6) \cdot V_{in} - (R_{11}/R_6) \cdot V_{ref}$$

In this circuit  $R_6 = R_{11}$  therefore;

$$V_{out} = 2 \cdot V_{in} - V_{ref}$$

The values of R4 and R5 have been selected so that when the dimmer is set to minimum the output of IC1a will be zero and as the dimmer output is increased the output of IC1a will increase to approximately 0.5V. The current sense resistor R14 is selected to give 0.5V when the lamp current is at maximum.

The error amplifier is implemented in IC1b. The lamp current feedback is fed into the non-inverting input and the control voltage is fed into the inverting input. The input resistors R12 and R14 have been chosen with an integrating capacitor of 10nF to give the best response and elimination of flicker but to avoid generating RF interference. The output of IC1b works as a current source. The more positive the output swings the more current is supplied to the CT pin of the IR2156 which is added to the current provided by RT causing CT to charge more quickly and the frequency to increase. If IC1b output is zero the frequency is at its minimum determined by the value of RT only. During preheat the frequency is set by RPH only and IC1b has no effect.

R9 ensures that even when the dimming reference voltage from the output of IC1a is zero, the error amplifier has a small voltage at the inverting input which means that it is impossible to dim the lamp below a particular point. This point is selected as the minimum lamp level at which the lamp will remain lit and will not flicker. The resistor R22 can be added if necessary to remove *striations* (dark rings) in the lamp that may occur at low dimming levels.

## IRPLCFL3

### Dimming Characteristic

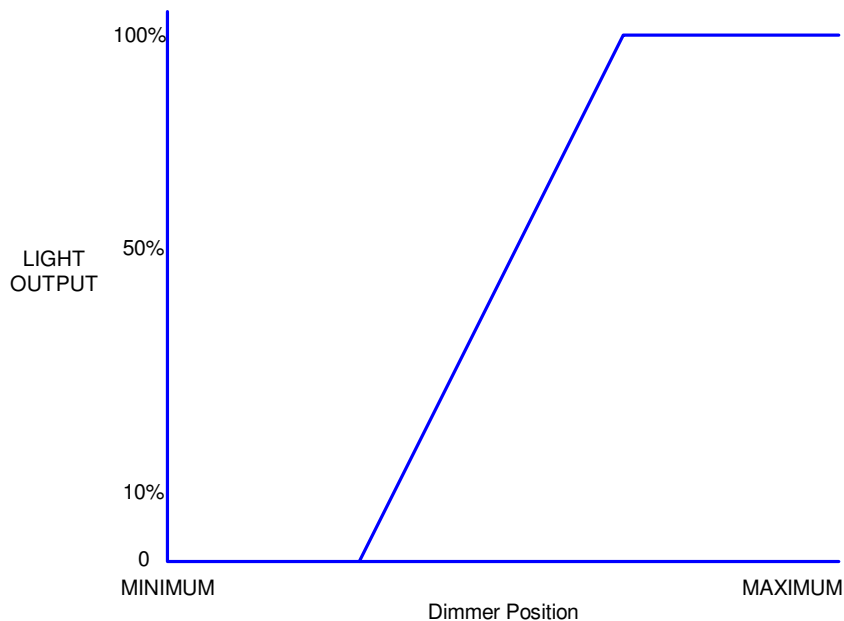

## DESIGN CONSIDERATIONS

### Protection Circuits

The SD pin of the IR2156 is used as lamp removal protection. If there is no lamp present the voltage at SD pin will be pulled above the 5.1V threshold via R22 and R21 charging C19. When a lamp is in circuit the voltage at the junction of R21 and R22 will be held low via D11 and R14.

The current sense resistor R20 has been selected so that if the lamp fails to strike as the frequency approaches resonance in ignition mode, IC2 will shut down thus protecting the Q1 and Q2. The VDC pin of IC2 is not used and needs to be tied to VCC via R15. In order for the system to operate the frequency of the ballast is controlled entirely through the closed loop system.

### Layout Issues

Care should be taken when laying out this circuit as with any closed loop control system. There should be a star point for all of the 0V returns, particularly IC1 pin 4, IC2 pin 8, R20, C12, R14, D12, C9, C10, C11 and C14, which is then returned to the negative side of C4 via a single track which is as short as possible. This point should be as close to IC2 COM pin 8 as possible and C21 should be located as close to IC2 as possible with short tracks. This will avoid potential ground loop problems.

D1 to D4, C3 and C4 should all be close together with connecting tracks as short as possible. The connecting track from C5 and C6 to the MOSFET half-bridge should also be kept short and as far away from the error amplifier as possible. C14 should be close to IC1 and IC2 with short tracks to the positive supply pins to provide maximum decoupling. All tracks carrying HF currents in the output section should be kept away from IC1 and IC2 and associated components.

## IRPLCFL3

### Component Selection

The output inductor and capacitor values should be chosen for the ballast to allow it to run at maximum brightness around 40kHz. This will minimize losses in the inductor. For this example the IR Ballast Design Assistant software has been used to select the required preheat, ignition and run frequencies for a TC-DEL 26W lamp giving an L of 2.3mH and C of 6.8nF. In this circuit the two capacitors C5 and C6 add to the tank capacitance so in practice a 4.7nF output capacitor is sufficient. The values of R16, R17 and C9 have been calculated to give a preheat frequency of 55kHz and a run frequency of 40kHz. The ignition frequency will be around 45kHz.

### Output Inductor Design

The output inductor L2 should be designed to allow a high peak ignition current without saturating. This is important as the IR2156 shutdown will be triggered if the inductor saturates. The ignition current depends on the type of lamp being used and must be kept to a minimum by ensuring the preheat is correct. To minimize losses in the inductor multi-stranded wire should be used in combination with Ferrite cores of sufficiently good quality. The best approach to design is to wind as many turns as possible of multi-stranded wire and have the largest gap possible to achieve the correct inductance. This will produce the highest available peak current before saturating the inductor. It is important to bear in mind that when the cores are hot the saturation point and hence the peak current for the inductor will be lower therefore a poorly designed inductor may result in the ballast shutting down during an attempted hot re-strike.

### Lamp Preheating

The lamp must be sufficiently preheated before ignition. The correct preheat current can be determined from published data or from International Rectifiers *Ballast Design Assistant* software.

The preheat time can be set by adjusting the value of C10. As a general rule the lamp filament should glow red before ignition. If preheat is insufficient the ballast is likely to shutdown during ignition because the output inductor will be unable to operate at the high current required. The number of turns in the auxiliary cathode windings of the output inductor L2 should be chosen to provide sufficient preheat. In designs for ballasts with integral lamps the shutdown pin can be grounded so that the inductor may saturate without shutting down the circuit.

The lamp filament (Cathode) resistance over the range of dimming levels must be between 3 and 5.5 times the resistance when cold. A simple method for determining the hot resistance is to first connect one cathode to a DC power supply via an ammeter and slowly increase the voltage from zero, noting the current at 1V intervals. This should be done until the cathode can be seen to be glowing red. When this occurs the voltage should not be increased further in order to prevent possible cathode damage. The resistance can then be calculated for each voltage and hence the acceptable voltage range can be found to comply with the 3 to 5.5 times cold resistance, which can be easily measured with a DMM.

## IRPLCFL3

Then when the ballast is being run a true RMS digital voltmeter can be connected across one cathode and the voltage can be observed at maximum and minimum brightness. The cathode voltage increases as the ballast is dimmed. The values of C17 and C18 will control how much it increases by, reducing the capacitance will reduce the amount by which the voltage rises. The values should be chosen to prevent the voltage exceeding the upper limit at minimum output.

It is important to bear in mind that using additional windings on the inductor to provide cathode heating means that power is now being transferred through the core and consequently the core losses will increase and hence the core operating temperature. The core will reach its highest operating temperature when the ballast is running at minimum brightness.

**The following component values have been selected for a 26W compact lamp. The circuit will need to be optimized for the particular lamp used to obtain best performance.**

### Demo Board Connections

The CFL3 demo board has two long leads for connection to the 120VAC mains supply. The board *must not* be connected to a supply greater than 120V. There are four output connections to be connected to a compact lamp. These are located at the opposite side of the board. The two upper connections go to one lamp cathode and the two lower connections go to the other lamp cathode.

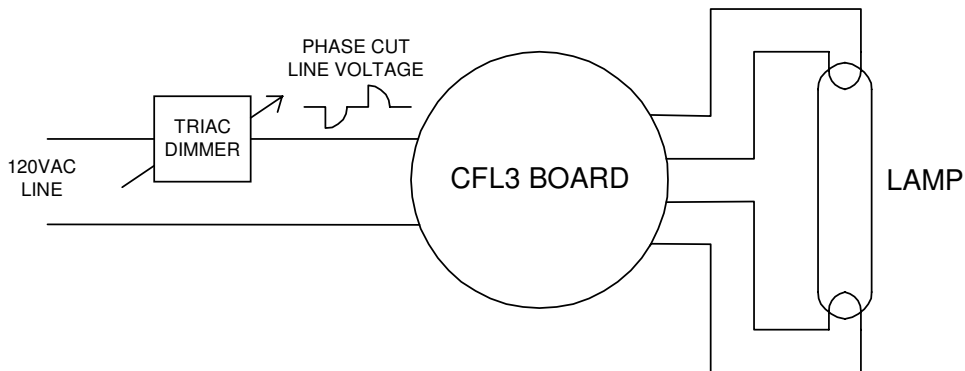



# IRPLCFL3

## BILL OF MATERIALS

Item #	Qty	Manufacturer	Part Number	Description	Reference
1	1	National Semiconductor	LM358AM	Dual Op Amp	IC1
2	1	International Rectifier	IR2156	Ballast Controller	IC2
3	2	International Rectifier	IRF730	MOSFET	Q1,2
4	5	On Semi	MURS160T	600V 1A Fast Diode SMD	D1,2,3,4,8
5	6	Microsemi	DL4148	Small Signal Diode SMD	D6,7,9,10,11,12
6	1	Diodes	BZT52C10	Zener Diode 10V 500mW SMD	D5
7	1	Renco	RL-5480-3-2700	Inductor 2.5mH 50hm	L1
8	1	B.I.Technologies	HM00-01741 (See Spec)	Inductor 2.3mH EF20	L2
9	1	Panasonic	ECQ-E2104KB	100nF 200V	C1
10	1	Panasonic	ECQ-E2224KF	220nF 200V	C2
11	2	Panasonic	EEU-EB2V220	22uF 200V 105C Electrolytic	C3,4
12	2	Roederstein	WY0102MCMB FOK	1nF 250Vac Dipped Ceramic	C5,6
13	1	Panasonic	ECE-AIVKG220	22uF 35V 105C Electrolytic	C7
14	1	Panasonic	ECJ-3FCIH103J	10nF 50V 1206	C8
15	1	Panasonic	ECU-VIH681KBM	680pF 50V NPO 1206	C9
16	1	Panasonic	ECJ-3VBIE334K	0.33uF 25V 1206	C10
17	1	Panasonic	ECU-VIH102JCH	1nF 50V 1206	C11
18	2	Panasonic	ECJ-3VBIH104K	100nF 50V 1206	C19,21
19	2	Panasonic	ECJ-3VB1E474K	470nF 50V 1206	C17,18
20	1	Panasonic	ECJ-D3A102KBN	1nF 1kV Ceramic	C13
21	1	Panasonic	ECE-AIEF2R2	2.2uF 25V 105C Electrolytic	C14
22	1	Wima	MKS2 Series	47nF 400V	C15

**IRPLCFL3**

23	1	Wima	MKP4 Series	4.7nF Polypropylene	1kV	C16
24	1	Mallory	TDC474K050N SE	0.47uF Tantalum Bead	10V	C12
25	1	Panasonic	ECQ-E1104KF	100nF	100V	C20
26	1	Yageo	CFR-50JB-5R6	5.6R	1W Axial	R1
27	1	Yageo	RSF100JB- 100R	100R	1W Axial	R2
28	1	Yageo	CFR-50JB-220K	220K	0.5W Axial	R3
29	1	Panasonic	ERJ- 8GEYJ683V	68K	1206	R4
30	1	Panasonic	ERJ- 8GEYJ332V	3K3	1206	R5
31	1	Yageo	CFR-25JB-100K	100K	0.25W Axial	R21
32	4	Panasonic	ERJ- 8GEYJ104V	100K	1206	R6,7,8,11
33	1	Panasonic	ERJ- 8GEYJ223V	22K	1206	R10
34	3	Panasonic	ERJ- 8GEYJ103V	10K	1206	R12,13,18
35	1	Panasonic	ERJ- 8GEYJ472V	4K7	1206	R15
36	1	Panasonic	ERJ- 8GEYJ333V	33K	1206	R16
37	1	Panasonic	ERJ- 8GEYJ473V	47K	1206	R17
38	1	Panasonic	ERJ- 8GEYJ102V	1K	1206	R19
39	1	Dale		0.5R	0.25W Axial	R20
40	1	Panasonic	ERJ- 8GEYJ105V	1M	1206	R22
41	1	Panasonic	ERJ- 8GEYJ220V	22R	1206	R14
42	1	Panasonic	ERJ- 8GEYJ225V	2M2	1206	R9
43	1	Yageo	CFR-50JB-220K	220K	0.5W	R22
44	3		Jumper Wire	18 AWG		LK1,2,3



**INDUCTOR SPECIFICATION**

CORE SIZE	E20/10/6 (EF20)
GAP LENGTH	1.0 mm
CORE MATERIAL	Philips 3C85, Siemens N27 or equivalent

WINDING	START PIN	FINISH PIN	TURNS	WI RE DIAMETER (mm)
MAIN	1	6	240*	10/38 Multistranded
ZX	n/a	n/a		
AUX	n/a	n/a		
CATHODE	2	5	5.5	26awg insulated
CATHODE	3	4	5.5	26awg insulated

PHYSICAL LAYOUT

(Vertical 6-Pin Bobbin)

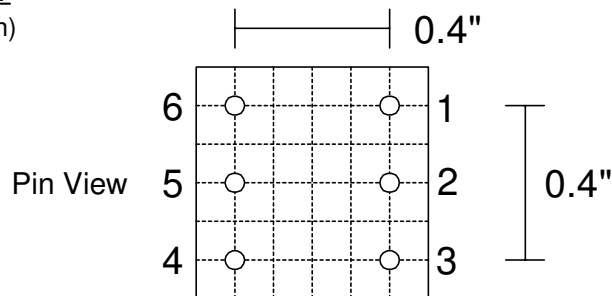

TEST

MAIN WINDING INDUCTANCE    MIN 2.1 mH    MAX 2.4 mH

\* Adjust turns for specified Inductance

## IRPLCFL3

### REFERENCES

Data Sheet No. PD60182-B “IR2156 Ballast Control IC”

Reference Design IRPLCFL2 “42W Compact Fluorescent Ballast”

International Rectifier Web Site [www.irf.com](http://www.irf.com)

**The following is a disclaimer regarding the IRPLCFL3 Ballast**

### NOTICE

Please be advised that anyone making, using or selling a ballast using the IRPLCFL3 ballast or a ballast designed or constructed in accordance with the design of the IRPLCFL3 ballast may need to obtain a license from Lutron Electronic Co., Inc., under patents US B1 5,041,763 and/or US B1 5,001,386.

International  
**IR** Rectifier

**IR WORLD HEADQUARTERS:** 233 Kansas St., El Segundo, California 90245 Tel: (310) 252-7105  
*Data and specifications subject to change without notice. 8/25/2003*