

# IRAUDAMP11

## 120W x 3 Channel Class D Audio Power Amplifier Using the IRS2053M and IRF6665

By

Jun Honda, Liwei Zheng



### CAUTION:

International Rectifier suggests the following guidelines for safe operation and handling of IRAUDAMP11 Demo board;

- Always wear safety glasses whenever operating Demo Board
- Avoid personal contact with exposed metal surfaces when operating Demo Board
- Turn off Demo Board when placing or removing measurement probes

**TABLE OF CONTENTS**

	<b>PAGE</b>
<b>INTRODUCTION</b> .....	<b>3</b>
<b>SPECIFICATIONS</b> .....	<b>3</b>
<b>CONNECTION SETUP</b> .....	<b>5</b>
<b>CONNECTOR DESCRIPTION</b> .....	<b>5</b>
<b>TEST PROCEDURES</b> .....	<b>6</b>
<b>PERFORMANCE AND TEST GRAPHS</b> .....	<b>7</b>
<b>CLIPPING CHARACTERISTICS</b> .....	<b>10</b>
<b>SOFT CLIPPING</b> .....	<b>10</b>
<b>EFFICIENCY</b> .....	<b>12</b>
<b>THERMAL CONSIDERATIONS</b> .....	<b>12</b>
THERMAL INTERFACE MATERIAL'S PRESSURE CONTROL.....	13
<b>POWER SUPPLY REJECTION RATIO (PSRR)</b> .....	<b>15</b>
<b>SHORT CIRCUIT PROTECTION RESPONSE</b> .....	<b>16</b>
<b>IRAUDAMP11 OVERVIEW</b> .....	<b>17</b>
<b>FUNCTIONAL DESCRIPTIONS</b> .....	<b>19</b>
IRS2053 GATE DRIVER IC.....	19
SELF-OSCILLATING FREQUENCY.....	20
ADJUSTMENTS OF SELF-OSCILLATING FREQUENCY.....	20
SELECTABLE DEAD-TIME.....	21
<b>PROTECTION SYSTEM OVERVIEW</b> .....	<b>22</b>
<b>CLICK AND POP NOISE REDUCTION</b> .....	<b>24</b>
<b>BUS PUMPING</b> .....	<b>24</b>
<b>INPUT SIGNAL AND GAIN SETTING</b> .....	<b>26</b>
<b>GAIN SETTING</b> .....	<b>26</b>
<b>IRAUDAMP11 FABRICATION MATERIALS</b> .....	<b>28</b>
<b>IRAUDAMP11 HARDWARE</b> .....	<b>31</b>
<b>IRAUDAMP11 PCB SPECIFICATIONS</b> .....	<b>32</b>
<b>REVISION CHANGES DESCRIPTIONS</b> .....	<b>35</b>

## Introduction

The IRAUDAMP11 Demo board is a reference design which uses only one IC (IRS2053M) to derive appropriate input signals, amplify the audio input, and achieve a three-channel 120 W/ch (4Ω, THD+N=1%) half-bridge Class D audio power amplifier. The reference design demonstrates how to use the IRS2053M Class D audio controller and gate driver IC, implement protection circuits, and design an optimum PCB layout using IRF6665 DirectFET MOSFETs. The reference design contains all the required housekeeping power supplies for ease of use. The three-channel design is scalable, for power and number of channels.

## Applications

- AV receivers
- Home theater systems
- Mini component stereos
- Powered speakers
- Sub-woofers
- Musical Instrument amplifiers
- Automotive after market amplifiers

## Features

Output Power:	120W x 3 channels (4Ω, THD+N=1%) or 170W x 3 channels (4Ω, THD+N=10%)
Residual Noise:	220μV, IHF-A weighted, AES-17 filter
Distortion:	0.02% THD+N @ 60W, 4Ω
Efficiency:	90% @ 120W, 4Ω, single-channel driven, Class D stage
Multiple Protection Features:	Over-current protection (OCP), high side and low side Over-voltage protection (OVP), Under-voltage protection (UVP), high side and low side Over-temperature protection (OTP)
PWM Modulator:	Self-oscillating half-bridge topology with optional clock synchronization

## Specifications

General Test Conditions (unless otherwise noted)		Notes / Conditions
Supply Voltages	±35V	
Load Impedance	4Ω	
Self-Oscillating Frequency	400kHz	No input signal, Adjustable
Gain Setting	28dB	1Vrms input yields rated power
Electrical Data		Notes / Conditions
IR Devices Used	IRS2053M Audio Controller and Gate-Driver, IRF6665 DirectFET MOSFETs	
Modulator	Self-oscillating, second order sigma-delta modulation, analog input	
Power Supply Range	± 25V to ±35V	Bipolar power supply
Output Power CH1-3: (1% THD+N)	120W	1kHz, ±35V
Output Power CH1-3: (10% THD+N)	170W	1kHz, ±35V

Rated Load Impedance	8-4Ω	Resistive load
Standby Supply Current	+75/-95mA	No input signal
Total Idle Power Consumption	6W	No input signal
Channel Efficiency	90%	Single-channel driven, 120W, Class D stage

**Audio Performance**

	<b>Class D Output</b>	<b>Notes / Conditions</b>
THD+N, 1W	0.015%	
THD+N, 10W	0.01%	1kHz, Single-channel driven
THD+N, 60W	0.02%	
THD+N, 100W	0.03%	
Dynamic Range	101dB	A-weighted, AES-17 filter, Single-channel operation
Residual Noise, 22Hz - 20kHzAES17	220μV	Self-oscillating – 400kHz
Damping Factor	67	1kHz, relative to 4Ω load
Channel Separation	75dB	100Hz
	75dB	1kHz
	70dB	10kHz
Frequency Response : 20Hz-20kHz	±1dB	1W, 4Ω - 8Ω Load
: 20Hz-35kHz	±3dB	

**Physical Specifications**

Dimensions	3.94"(L) x 2.83"(W) x 0.85"(H) 100 mm (L) x 72 mm (W) x 21.5 mm(H)
Weight	0.130kgm

## Connection Setup

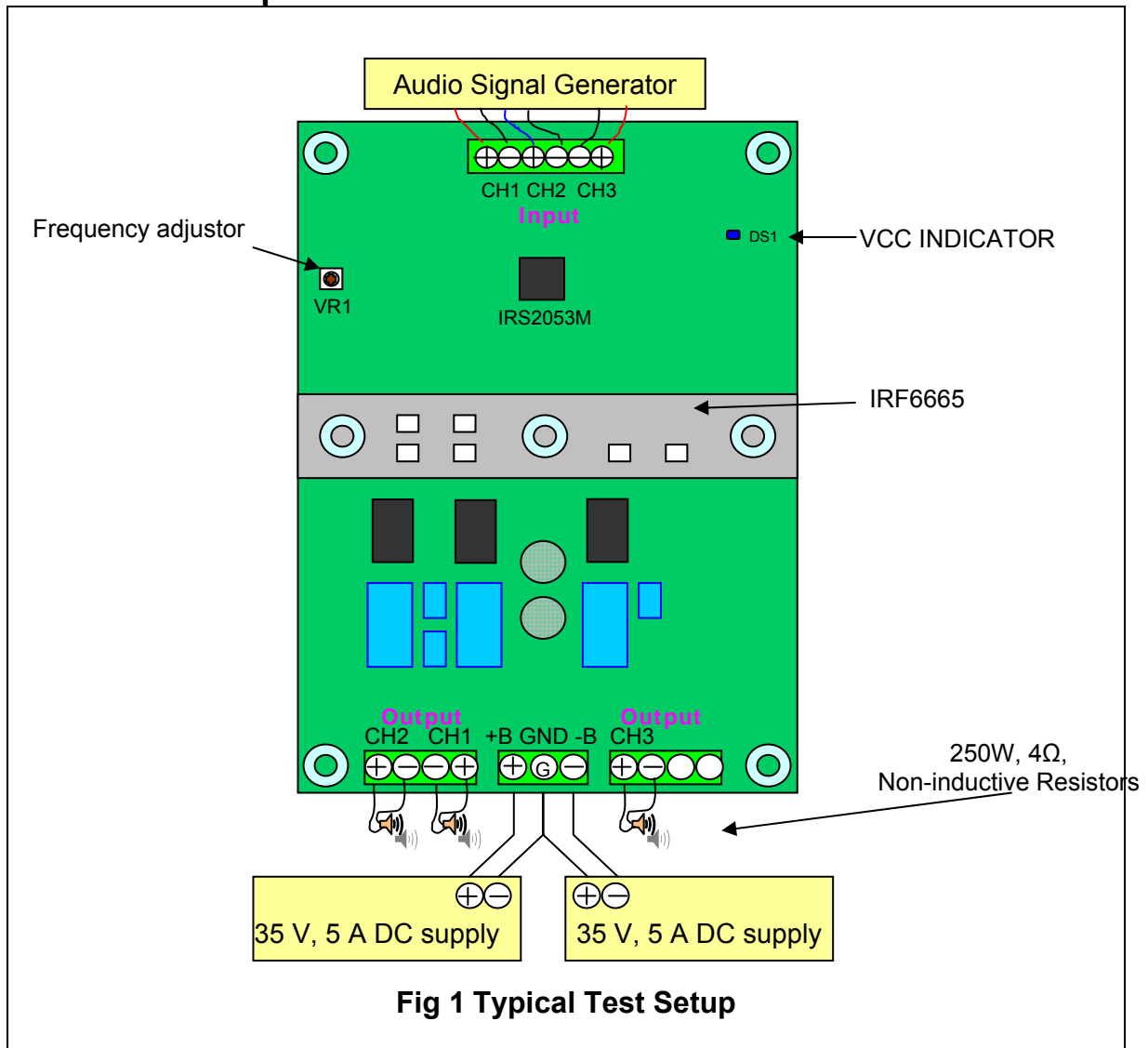

## Connector Description

CH1 IN	CN1	Analog input for CH1
CH2 IN	CN1	Analog input for CH2
CH3 IN	CN1	Analog input for CH3
SUPPLY	P1	Positive and negative supply (+B / -B)
CH1 OUT	P2	Output for CH1
CH2 OUT	P2	Output for CH2
CH3 OUT	P3	Output for CH3

## Test Procedures

### Test Setup:

1. Connect 4 $\Omega$ -200 W dummy loads to 3 output connectors (P2 and P3 as shown on Fig 1) and an Audio Precision analyzer (AP).
2. Connect the Audio Signal Generator to CN1 for CH1~CH3 respectively (AP).
3. Set up the dual power supply with voltages of  $\pm 35V$ ; current limit to 5A.
4. TURN OFF the dual power supply before connecting to On of the unit under test (UUT).
5. Connect the dual power supply to P1. as shown on Fig 1

### Power up:

6. Turn ON the dual power supply. The  $\pm B$  supplies must be applied and removed at the same time.
7. The Blue LED should turn ON immediately and stay ON
8. Quiescent current for the positive supply should be 75mA  $\pm$ 10mA at +35V.
9. Quiescent current for the negative supply should be 95mA  $\pm$ 10mA at -35V.

### Switching Frequency test

10. With an Oscilloscope, monitor the switching waveform at test points VS1~VS3. Adjust VR1 to set the self oscillating frequency to 400 kHz  $\pm$  25 kHz when DUT in clock synchronize mode.

### Functionality Audio Tests:

11. Set the signal generator to 1kHz, 20 mV<sub>RMS</sub> output.
12. Connect the audio signal generator to CN1(Input of CH1,CH2,CH3)
13. Sweep the audio signal voltage from 15 mV<sub>RMS</sub> to 1 V<sub>RMS</sub>.
14. Monitor the output signals at P2/P3 with an oscilloscope. The waveform must be a non distorted sinusoidal signal.
15. Observe that a 1 V<sub>RMS</sub> input generates an output voltage of 25.52 V<sub>RMS</sub>(CH1/CH2). The ratio, R4x/(R3x) and R30x/(R31x), determines the voltage gain of IRAUDAMP11.

### Test Setup using Audio Precision (Ap):

16. Use an unbalanced-floating signal from the generator outputs.
17. Use balanced inputs taken across output terminals, P2 and P3.
18. Connect Ap frame ground to GND at terminal P1.
19. Select the AES-17 filter(pull-down menu) for all the testing except frequency response.
20. Use a signal voltage sweep range from 15 mV<sub>RMS</sub> to 1 V<sub>RMS</sub>.
21. Run Ap test programs for all subsequent tests as shown in Fig 2- Fig 7below.

Performance and test graphs

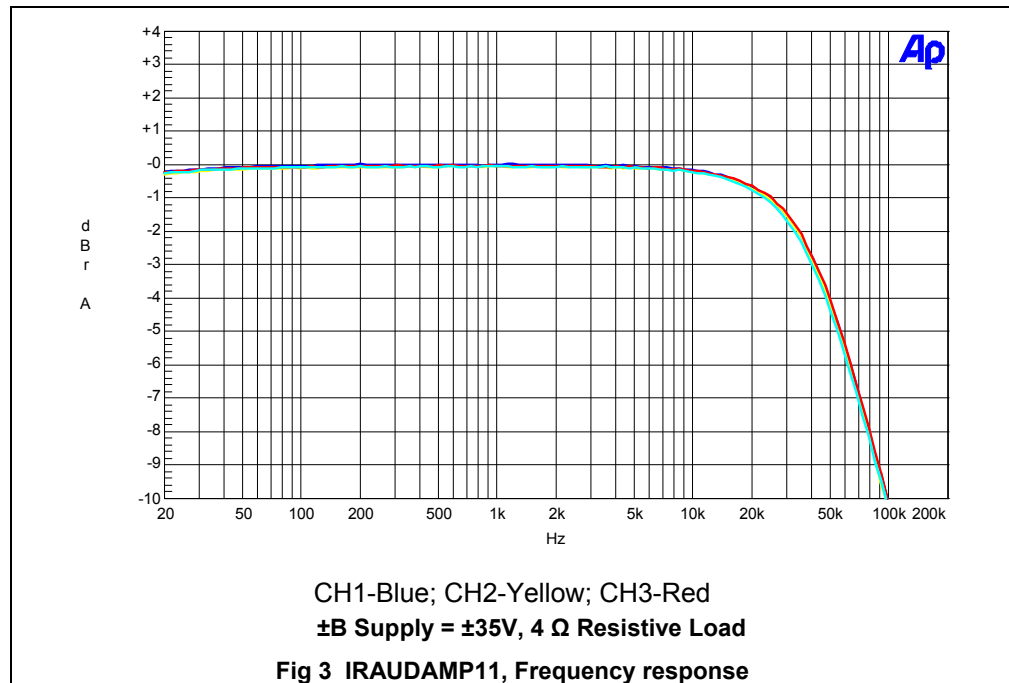
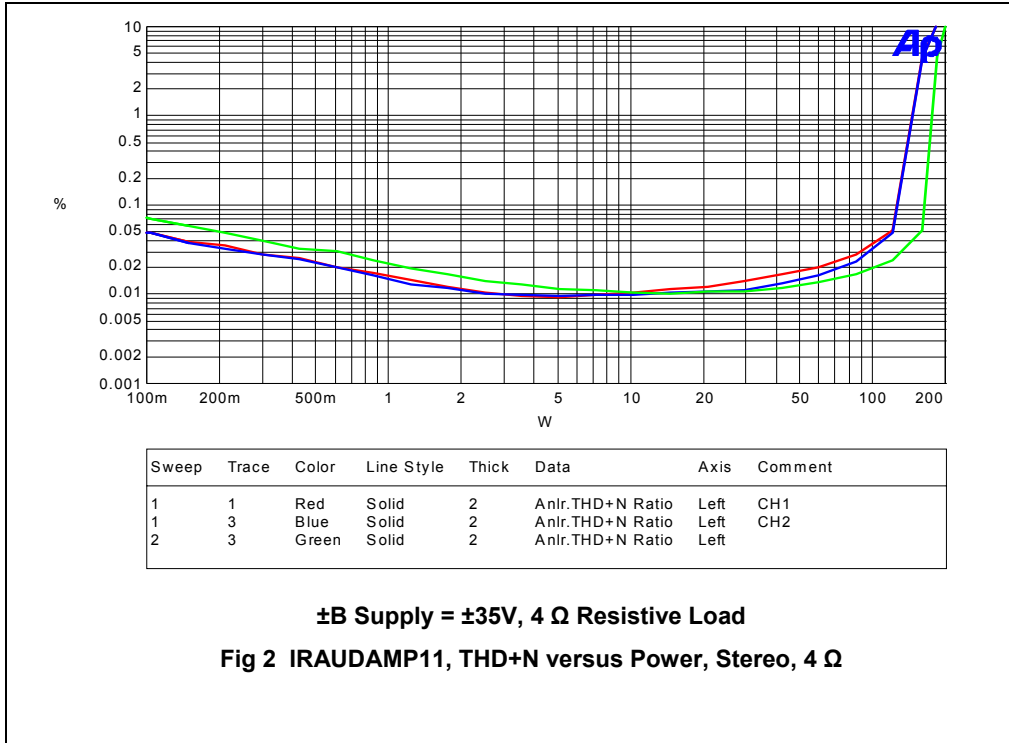

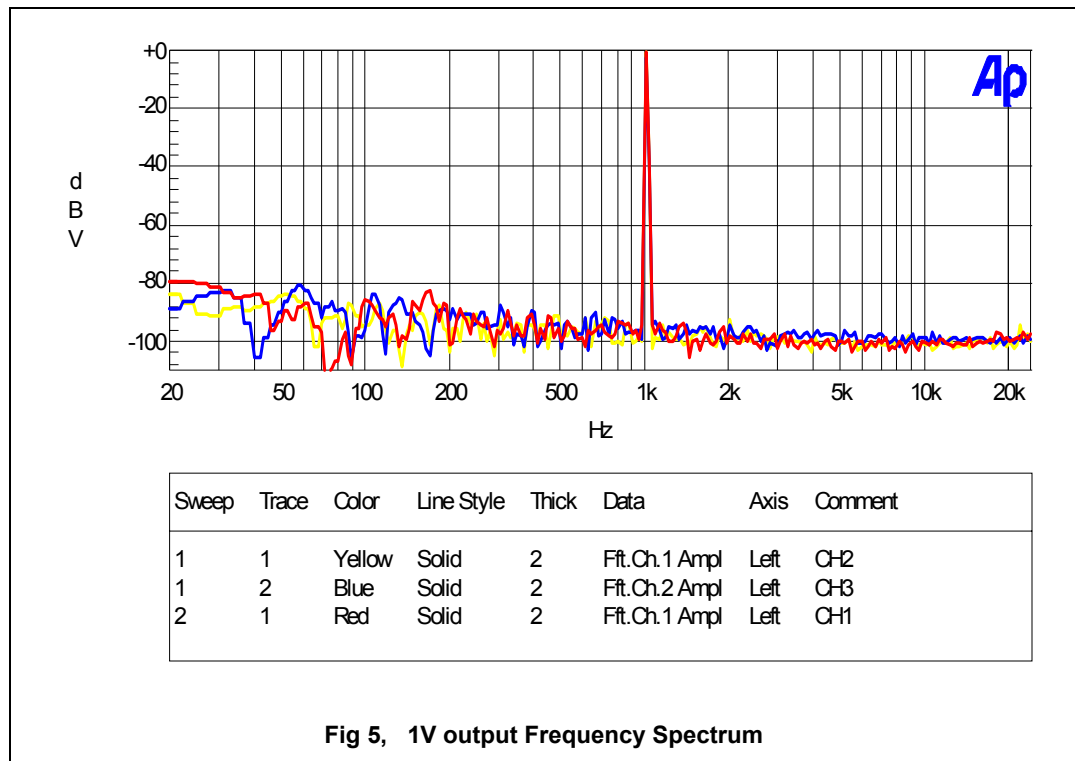
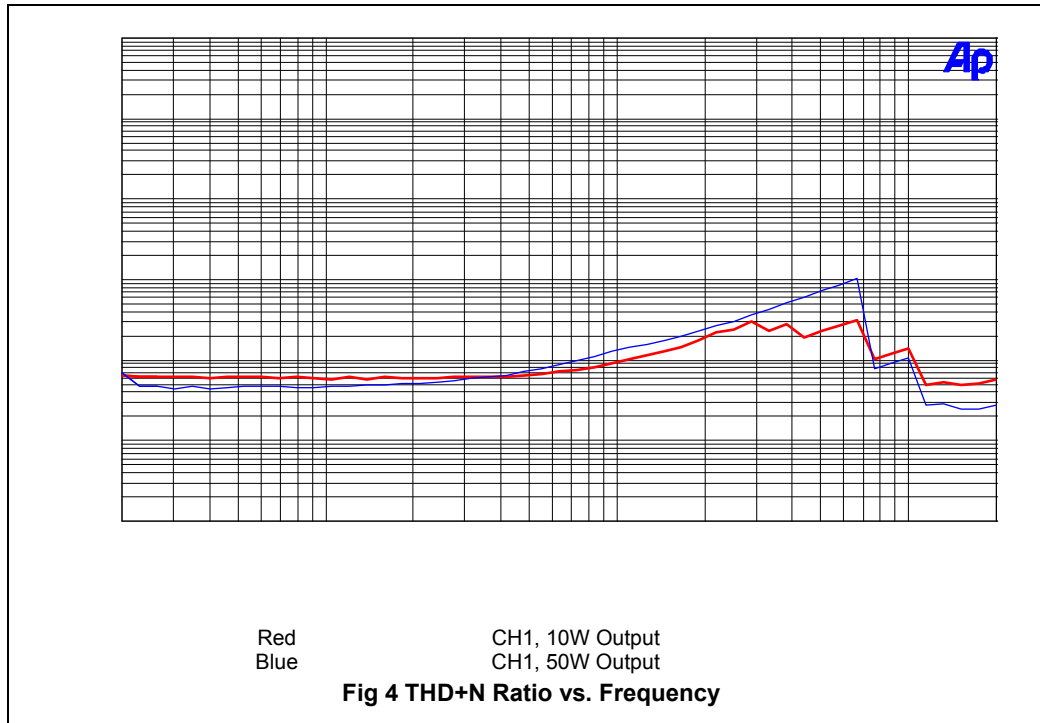

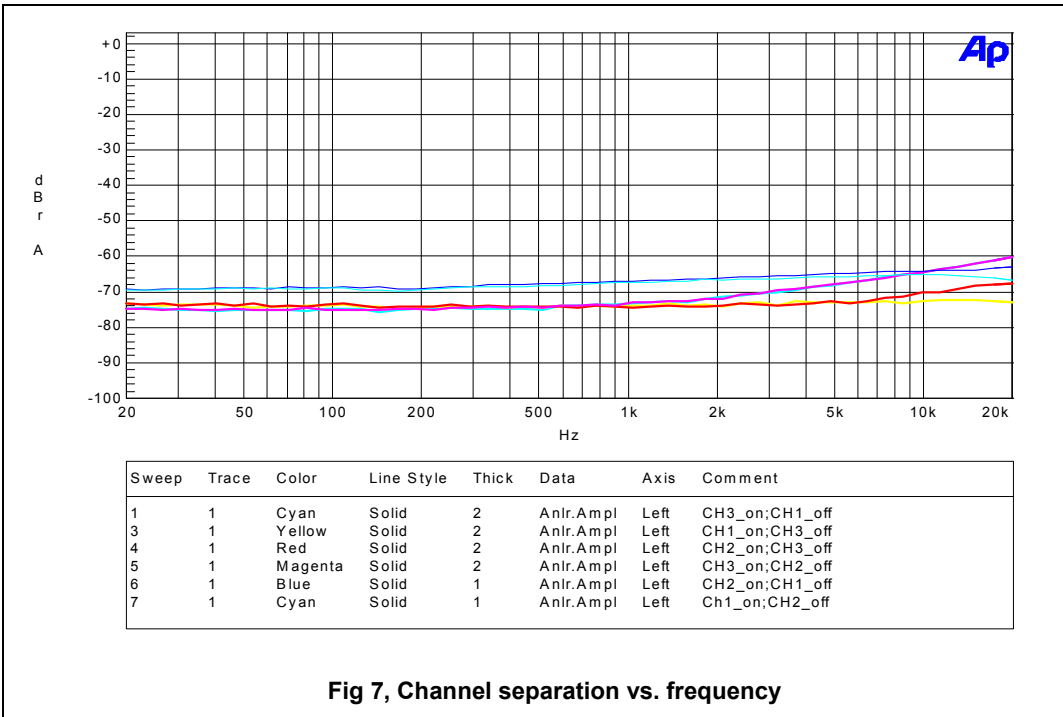
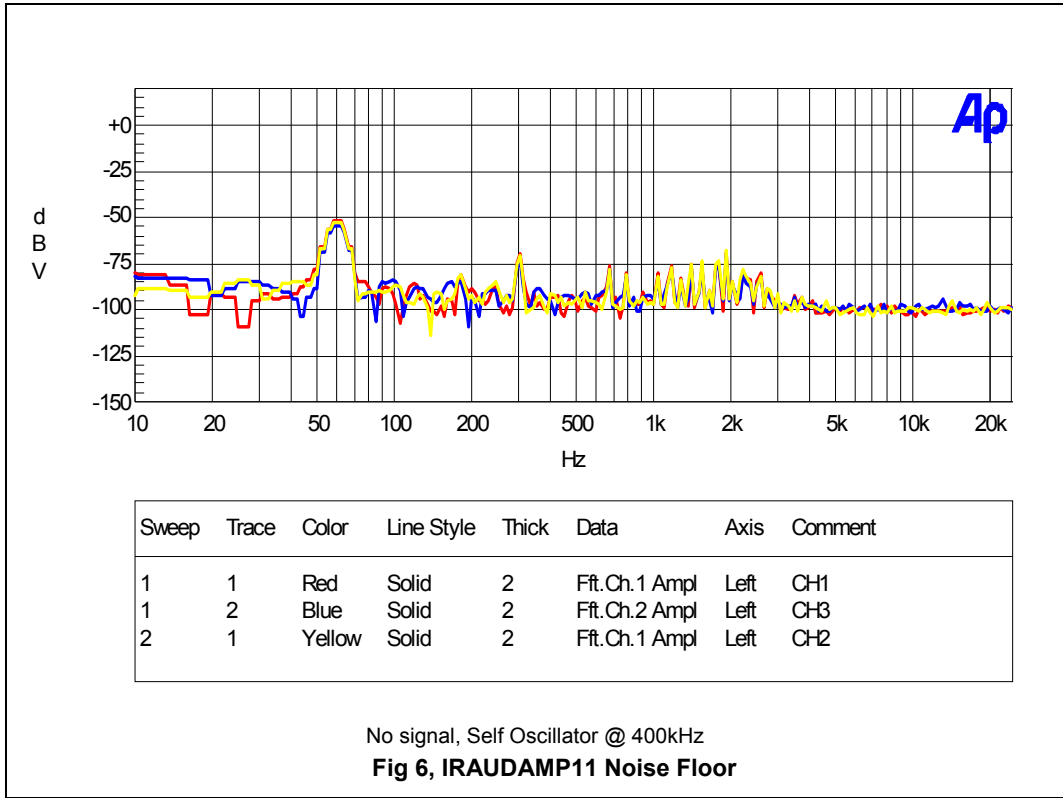

## Clipping characteristics

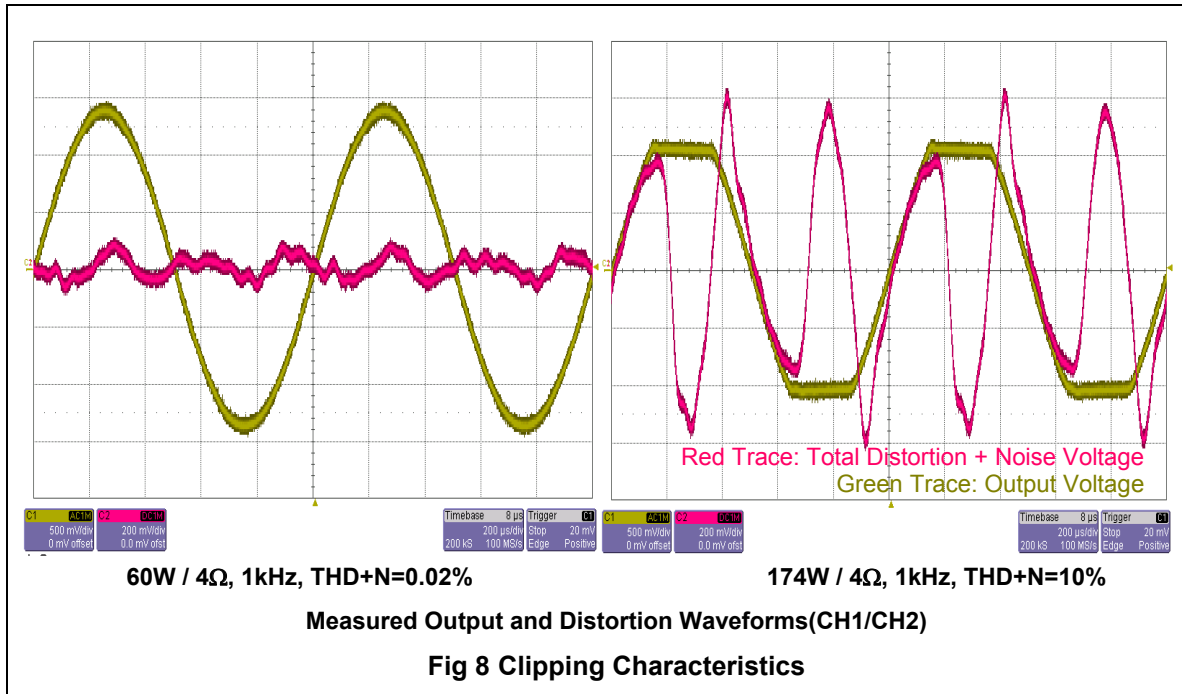

## Soft Clipping

IRS2053M has Clipping detection function, it monitors error voltage in COMP pin with a window comparator and pull an open drain nmos referenced to GND. Threshold to detect is at 10% and 90% of VAA-VSS. Each channel has independent CLIP outputs. Once IRS2053M detects Clipping, the CLIP pin will generate pulses to trigger soft clipping circuit as Fig 9, which limits output's maximum power.

Fig10 shows 20Hz and 20 kHz THD+N versus Power graph in CH3; it shows limitation of output's power with different frequency.

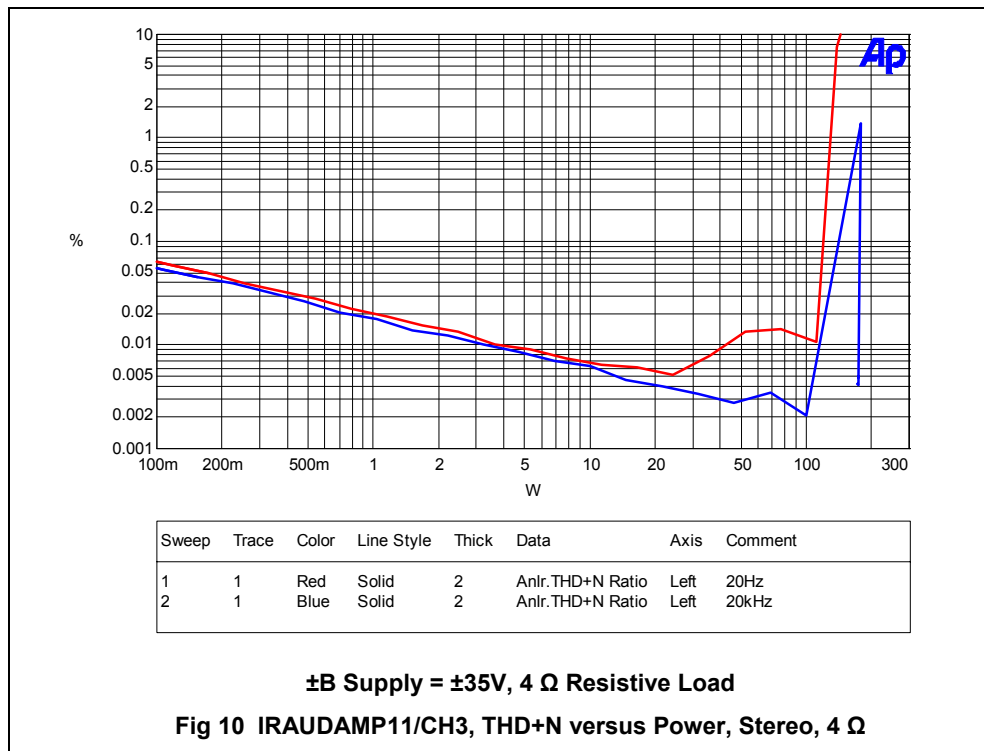
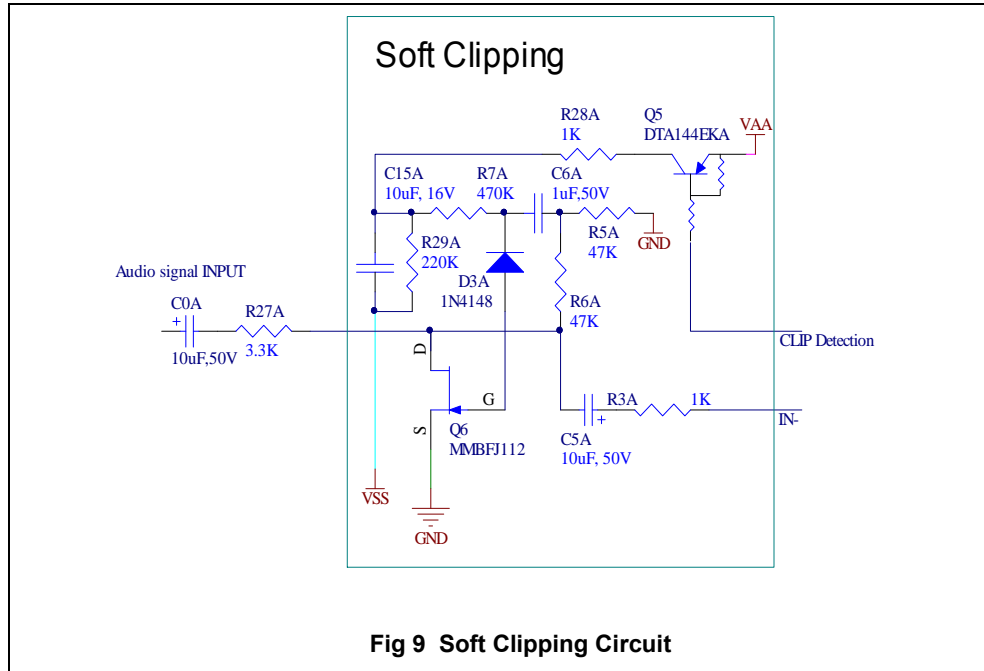

## Efficiency

Fig 11 shows efficiency characteristics of the IRAUDAMP11. The high efficiency is achieved by following major factors:

- 1) Low conduction loss due to the DirectFETs offering low  $R_{DS(ON)}$
- 2) Low switching loss due to the DirectFETs offering low input capacitance for fast rise and fall times

Secure dead-time provided by the IRS2053M, avoiding cross-conduction.

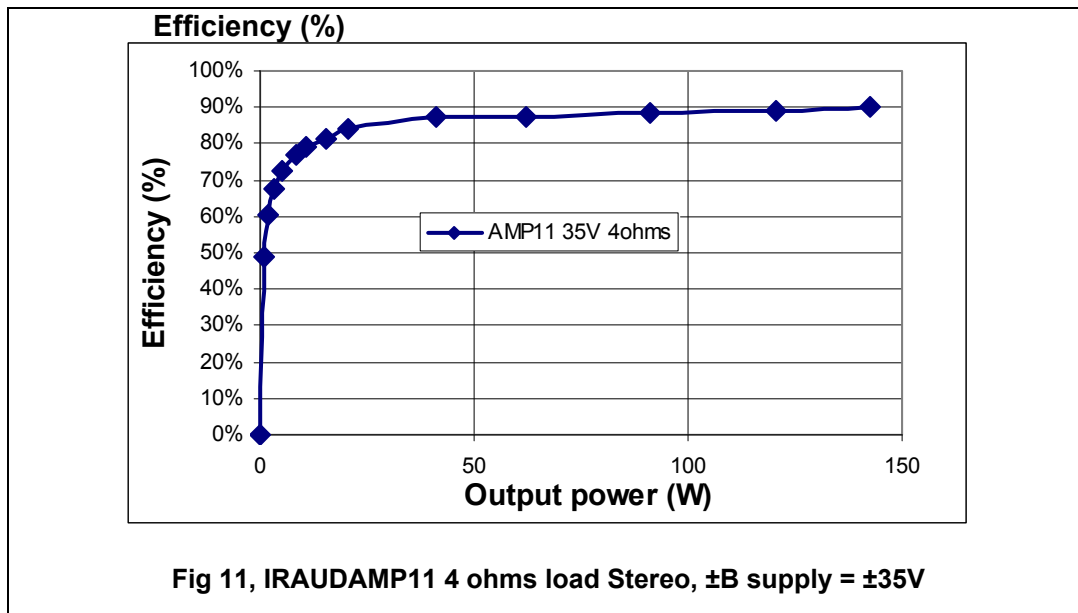

## Thermal Considerations

With this high efficiency, the IRAUDAMP11 design can handle one-eighth of the continuous rated power, which is generally considered to be a normal operating condition for safety standards, without additional heatsinks or forced air-cooling.

### Thermal Interface Material's Pressure Control

The pressure between DirectFET & TIM (Thermal Interface Material) is controlled by depth of Heat Spreader's groove. Choose TIM which is recommended by [IR](#). (Refer to AN-1035 for more details). TIM's manufacturer thickness, conductivity, & etc. determine pressure requirement. Below shows selection options recommended:

**Common Thermal Interface Materials Cost Trades**

Mfr.	Material	Type	Thickness (mils)	Pressure Required	Dispense/Apply	Clips/Screws	Can be applied to heat sink?	Mechanical Placement?
Dow Corning	1-4173	1 part heat-cured adhesive	#	Yes	Dispense	Clips	N	Y
Dow Corning	SE 4451	2 part heat-cured adhesive	#	Yes	Dispense	Clips	N	Y
Dow Corning	3-6652	2 part heat-cured adhesive	#	Yes	Dispense	Clips	N	Y
Dow Corning	TP-1500 Pad	Tacky - Phase Change at 52°C	10	>5psi, 20psi typ	Apply	Clips	Y	Y
Bergquist	Gap Pad 3000	conformable filled polymer sheet	15	>10psi	Apply	Clips/Screws	N	Y
Bergquist	Gap Pad 2000	conformable filled polymer sheet	10	>10psi	Apply	Clips/Screws	N	Y
Bergquist	Hi Flow 300	Phase Change at 55°C	2.4	>10psi	Apply	Clips	Y	*
Bergquist	Hi Flow 625	Phase Change at 65°C	5	>10psi	Apply	Clips	Y	*
Bergquist	Hi Flow 818	Phase Change at 65°C	5.5	>10psi	Apply	Clips	Y	*
Bergquist	Sil Pad 800	Conformable silicone elastomer	5	>10 higher better	Apply	Clips/Screws	Y	*
Bergquist	Sil Pad 900	Conformable silicone elastomer	9	>10 higher better	Apply	Clips/Screws	Y	*
Bergquist	Sil Pad A1500	Conformable silicone elastomer	10	10-50psi	Apply	Clips/Screws	Y	*
Bergquist	Sil Pad A2000	Conformable silicone elastomer	10	10-50psi	Apply	Clips/Screws	Y	*
Bergquist	Bond Ply 100	Pressure sensitive adhesive tape	5	>10psi	Apply	Clips	Y	Y
Bergquist	Bond Ply 100	Pressure sensitive adhesive tape	11	>10psi	Apply	Clips	Y	Y
Thermoset (Lord)	Gelease MG-120	Thermal grease/gel	#	5-7lbf	Dispense	Clips	N	Y
Shin Etsu	X-23-7783D	Thermal grease	#	-	Dispense	Clips	N	Y
Shin Etsu	X-23-7762	Thermal grease	#	-	Dispense	Clips	N	Y

Fig 12 TIM Information

Check the TIM's compression deflection with constant rate of strain (example as Fig.13) base on manufacturer's datasheet. According to the stress requirement, find strain range for the TIM. Then, calculate heat spreader groove depth as below:

$$\text{Groove Depth} = \text{DirectFET's Height} + \text{TIM's Thickness} * \text{strain}$$

\*\*DirectFET's height should be measured from PCB to the top of DirectFET after reflow. The average height of IRF6665 is 0.6mm.

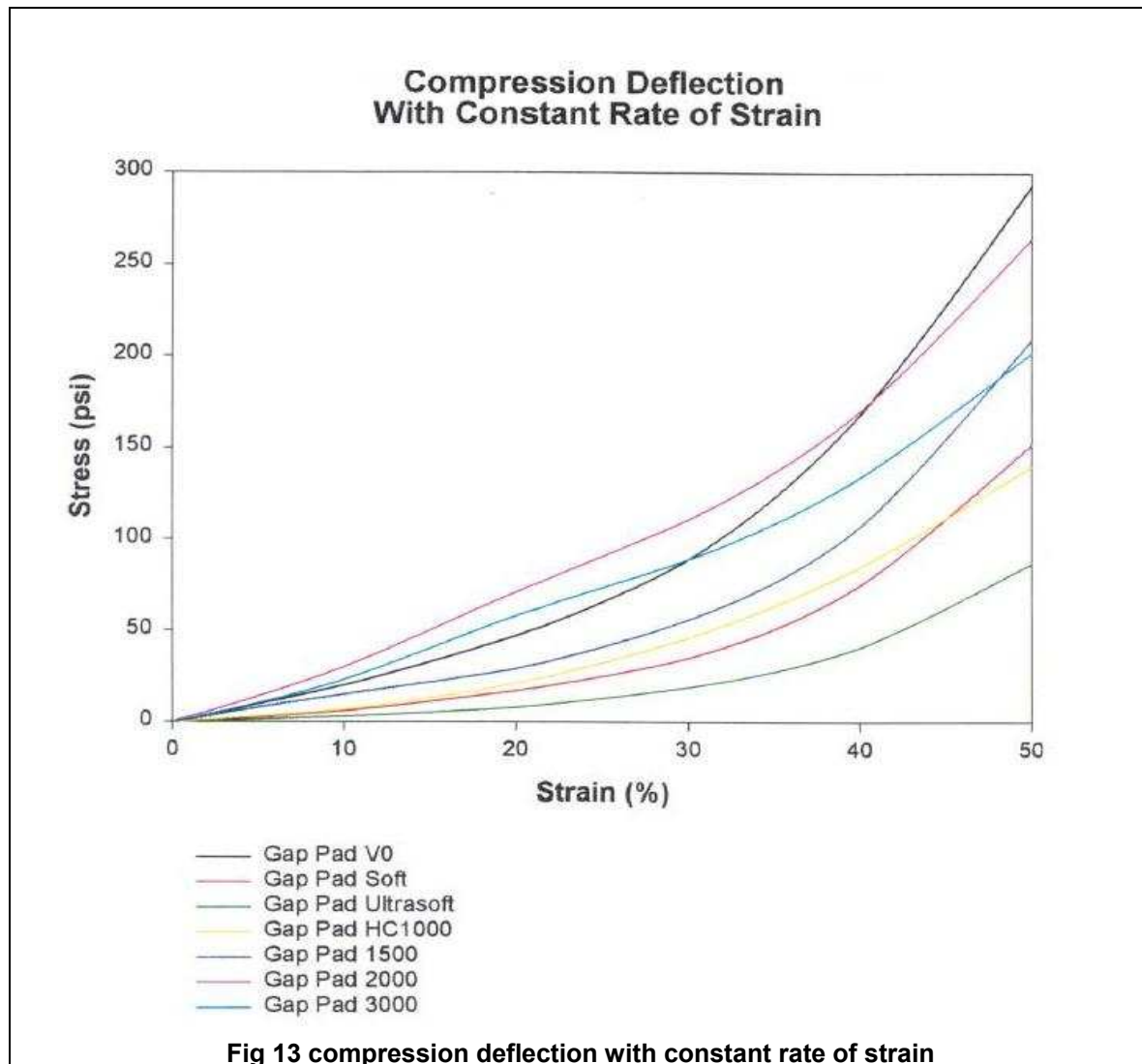

## Power Supply Rejection Ratio (PSRR)

The IRAUDAMP11 obtains good power supply rejection ratio of -68 dB at 1kHz shown in Fig 14. With this high PSRR, IRAUDAMP11 accepts any power supply topology when the supply voltages fit between the min and max range.

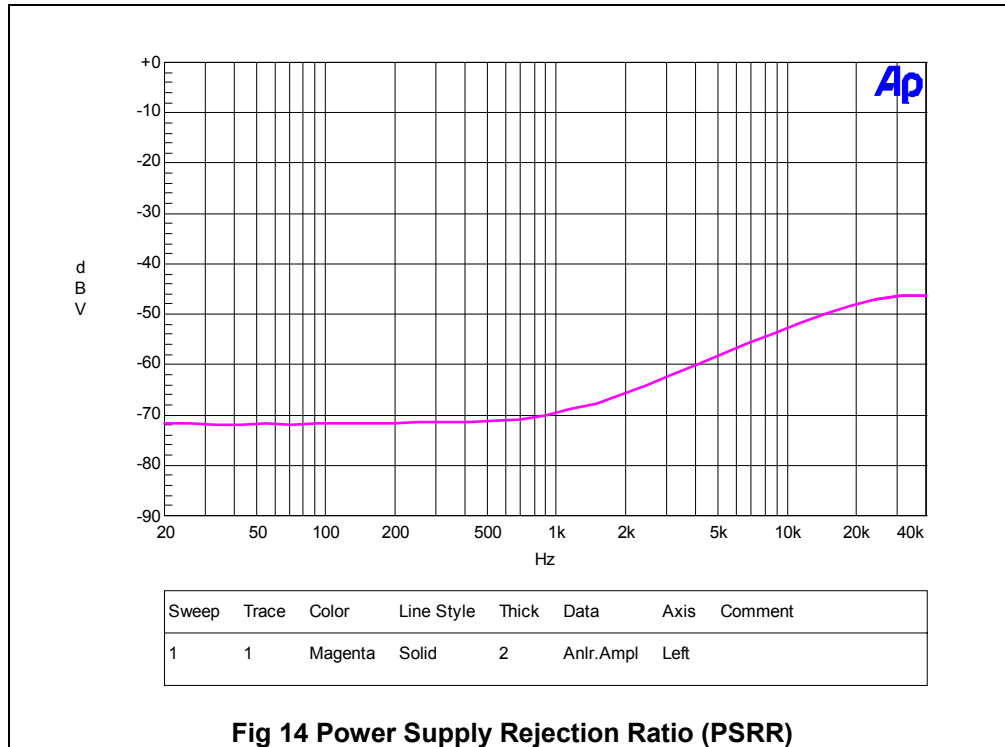

## Short Circuit Protection Response

Figs 15-16 show over current protection reaction time of the IRAUDAMP11 in a short circuit event. As soon as the IRS2053M detects an over current condition, it shuts down PWM. After one second, the IRS2053M tries to resume the PWM. If the short circuit persists, the IRS2053M repeats try and fail sequences until the short circuit is removed.

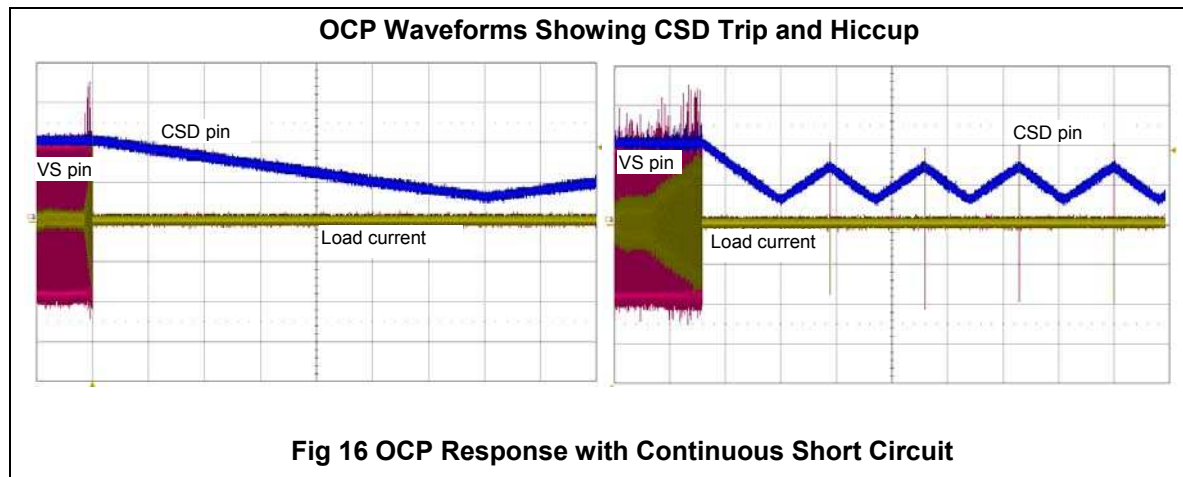
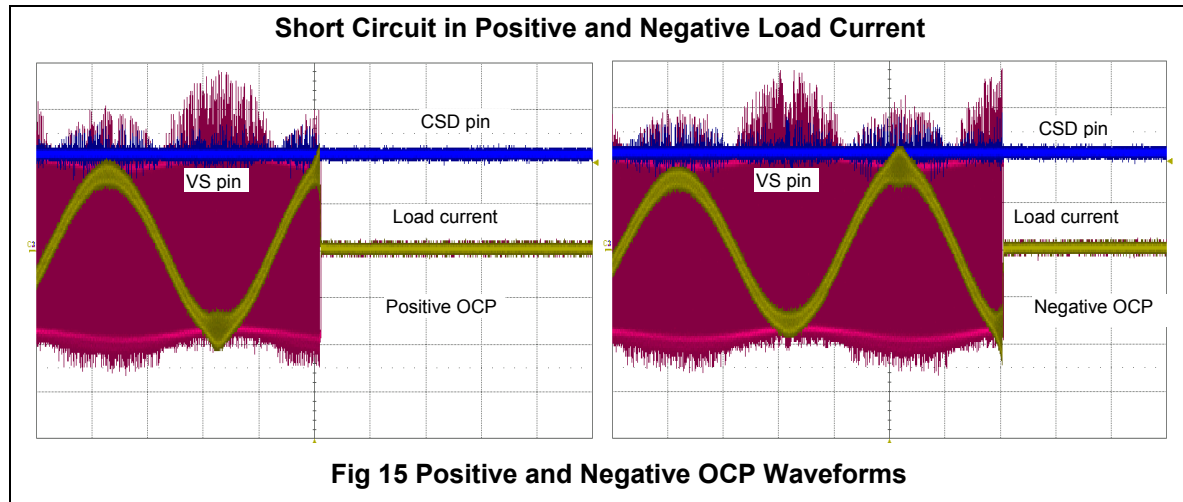

## IRAUDAMP11 Overview

The IRAUDAMP11 features a 3CH self-oscillating type PWM modulator for the smallest space, highest performance and robust design. This topology represents an analog version of a second-order sigma-delta modulation having a Class D switching stage inside the loop. The benefit of the sigma-delta modulation, in comparison to the carrier-signal based modulation, is that all the error in the audible frequency range is shifted to the inaudible upper-frequency range by nature of its operation. Also, sigma-delta modulation allows a designer to apply a sufficient amount of error correction.

The IRAUDAMP11 self-oscillating topology consists of following essential functional blocks.

- Front-end integrator
- PWM comparator
- Level shifters
- Gate drivers and MOSFETs
- Output LPF

### Integrator

Referring to Fig 17 below, the input operational amplifier of the IRS2053M forms a front-end second-order integrator with R3x, C2x, C3x, and R2x. The integrator that receives a rectangular feedback signal from the PWM output via R4x and audio input signal via R3x generates a quadratic carrier signal at the COMP pin. The analog input signal shifts the average value of the quadratic waveform such that the duty cycle varies according to the instantaneous voltage of the analog input signal.

### PWM Comparator

The carrier signal at the COMP pin is converted to a PWM signal by an internal comparator that has a threshold at middle point between VAA and VSS. The comparator has no hysteresis in its input threshold.

### Level Shifters

The internal input level-shifter transfers the PWM signal down to the low-side gate driver section. The gate driver section has another level-shifter that level shifts up the high-side gate signal to the high-side gate driver section.

## Gate Drivers and DirectFETs

The received PWM signal is sent to the dead-time generation block where a programmable amount of dead time is added into the PWM signal between the two gate output signals of LO and HO to prevent potential cross conduction across the output power DirectFETs. The high-side level-shifter shifts up the high-side gate drive signal out of the dead-time block.

Each channel of the IRS2053M's drives two DirectFETs, high- and low-sides, in the power stage providing the amplified PWM waveform.

## Output LPF

The amplified PWM output is reconstructed back to an analog signal by the output LC LPF. Demodulation LC low-pass filter (LPF) formed by L1 and C13, filters out the Class D switching carrier signal leaving the audio output at the speaker load. A single stage output filter can be used with switching frequencies of 400 kHz and greater; a design with a lower switching frequency may require an additional stage of LPF.

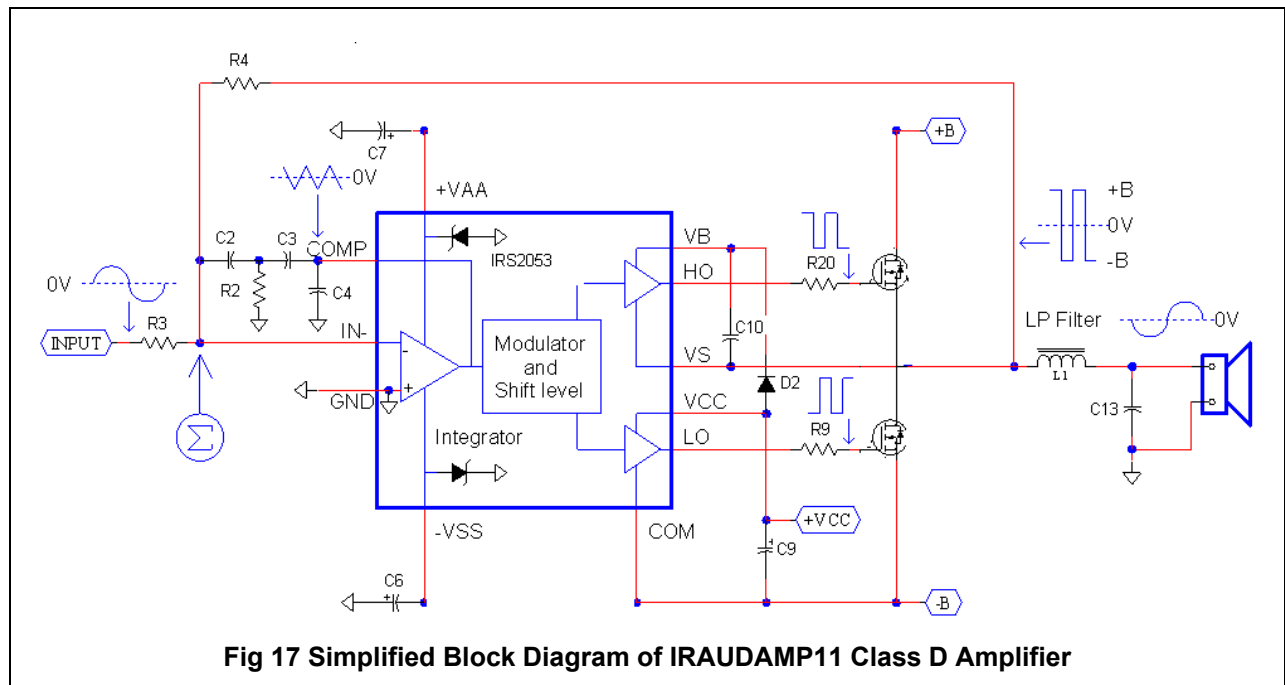

## Functional Descriptions

### IRS2053M Gate Driver IC

The IRAUDAMP11 uses the IRS2053M, a 3 Channel high-voltage (up to 200 V), high-speed power MOSFET driver with internal dead-time and protection functions specifically designed for Class D audio amplifier applications. These functions include OCP and UVP. The IRS2053M integrates bi-directional over current protection for both high-side and low-side MOSFETs. The dead-time can be selected for optimized performance according to the size of the MOSFET, minimizing dead-time while preventing shoot-through. As a result, there is no gate-timing adjustment required externally. Selectable dead-time through the DT pin voltage is an easy and reliable function which requires only two external resistors, R12 and R13 as shown on Fig 18 or Fig 24 below.

The IRS2053M offers the following functions.

- PWM modulator
- Dead-time insertion
- Over current protection
- Under voltage protection
- Level shifters

Refer to IRS2053M datasheet and AN-1158 for more details.

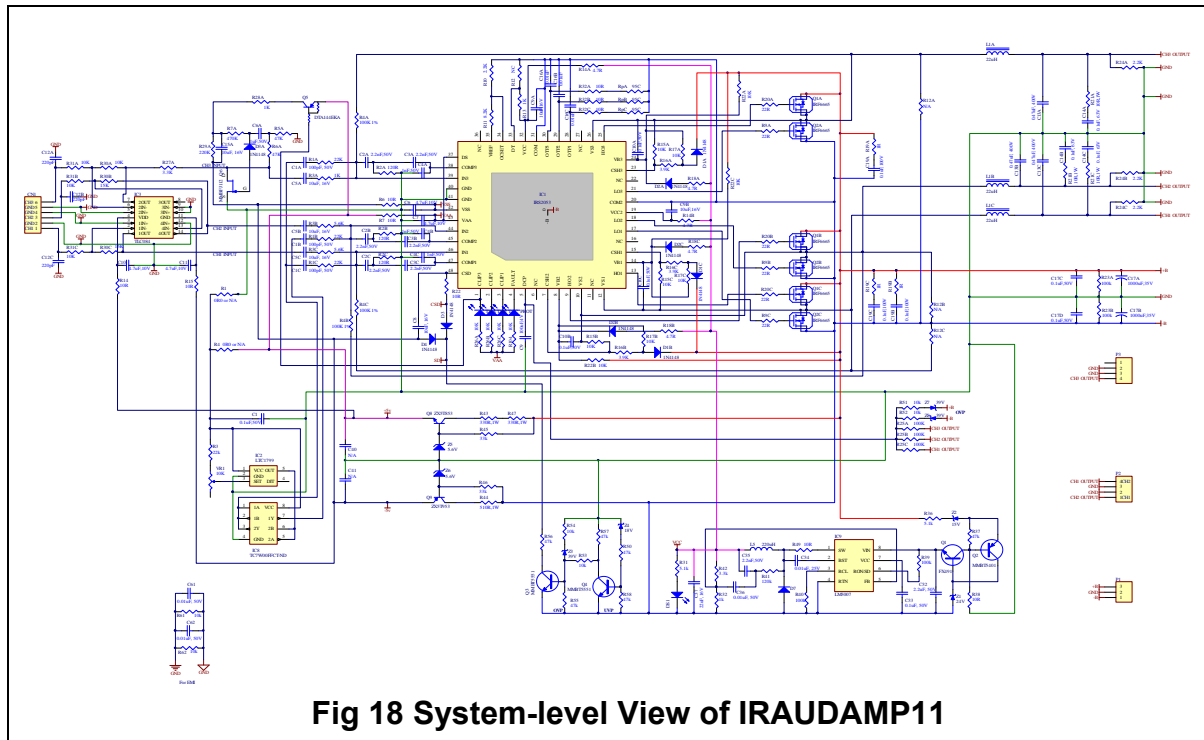

Fig 18 System-level View of IRAUDAMP11

## Self-Oscillating Frequency

Self-oscillating frequency is determined by the total delay time along the control loop of the system; the propagation delay of the IRS2053M, the DirectFETs switching speed, the time-constant of front-end integrator (R2, R3, R4, C2, C3 ). Variations in +B and –B supply voltages also affect the self-oscillating frequency.

The self-oscillating frequency changes with the duty ratio. The frequency is highest at idling. It drops as duty cycle varies away from 50%.

## Adjustments of Self-Oscillating Frequency

Use R2 to set different self-oscillating frequencies. The PWM switching frequency in this type of self-oscillating switching scheme greatly impacts the audio performance, both in absolute frequency and frequency relative to the other channels. In absolute terms, at higher frequencies, distortion due to switching-time becomes significant, while at lower frequencies, the bandwidth of the amplifier suffers. In relative terms, interference between channels is most significant if the relative frequency difference is within the audible range.

Normally, when adjusting the self-oscillating frequency of the different channels, it is suggested to either match the frequencies accurately, or have them separated by at least 25kHz. Under the normal operating condition with no audio input signal, the switching-frequency is set around 400kHz in the IRAUDAMP11.

### Selectable Dead-time

The dead-time of the IRS2053 is set based on the voltage applied to the DT pin. Fig 19 lists the suggested component value for each programmable dead-time between 45 and 105 ns. All the IRAUDAMP11 models use DT1 (45ns) dead-time.

Dead-time Mode	R1	R2	DT/SD Voltage
DT1	<10k	Open	V <sub>cc</sub>
DT2	5.6kΩ	4.7kΩ	0.46 x V <sub>cc</sub>
DT3	8.2kΩ	3.3kΩ	0.29 x V <sub>cc</sub>
DT4	Open	<10k	COM

Recommended Resistor Values for Dead Time Selection

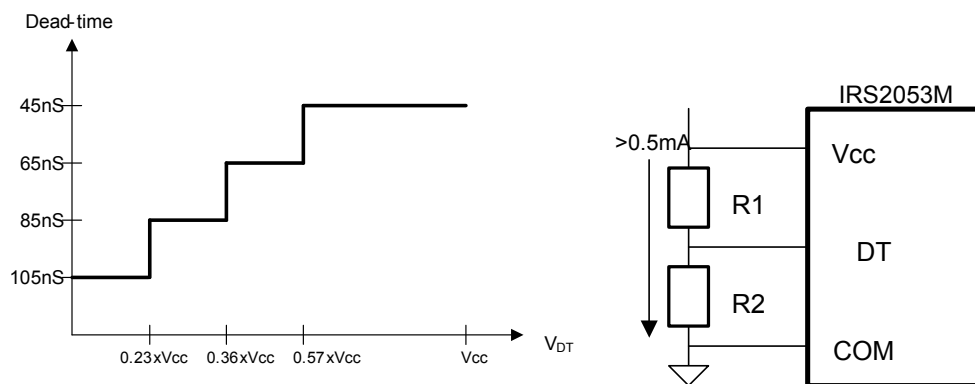
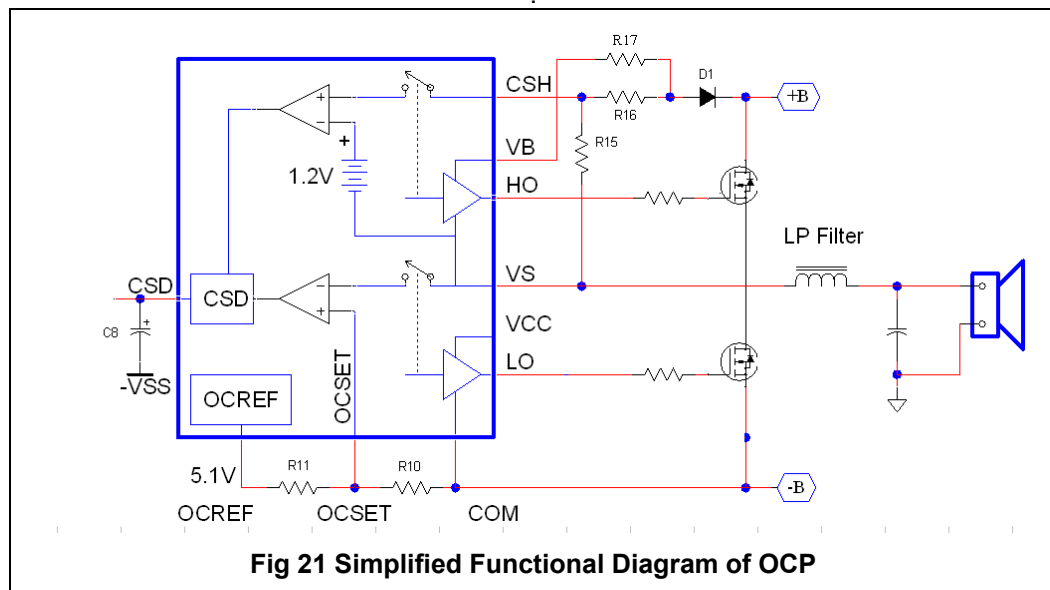
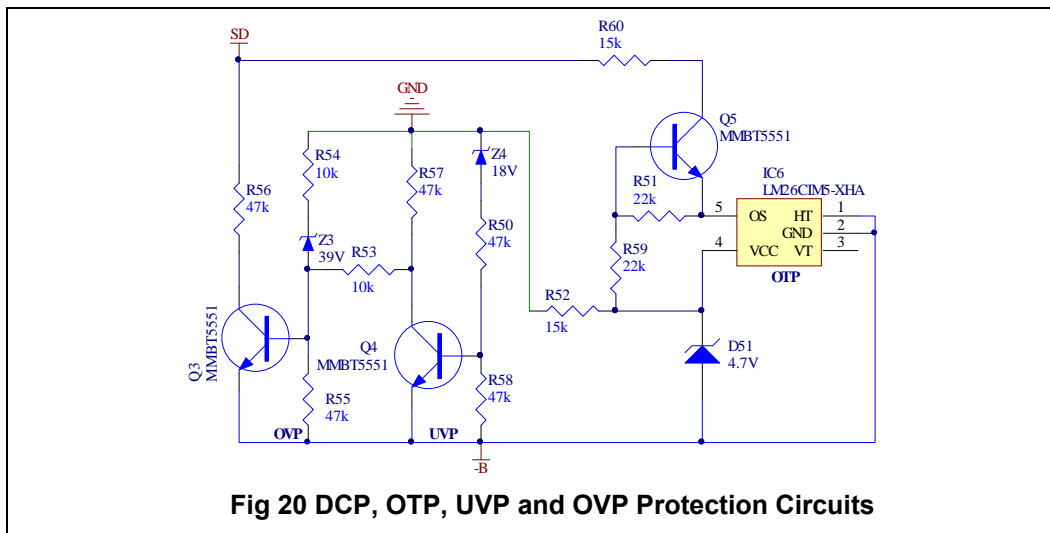

Fig 19 Dead-time Settings vs. V<sub>DT</sub> Voltage

## Protection System Overview

The IRS2053M integrates over current protection (OCP) inside the IC. The rest of the protections, such as over-voltage protection (OVP), under-voltage protection (UVP), and over temperature protection (OTP), are detected externally to the IRS2053M (Fig 20).

The external shutdown circuit will disable the output by pulling down CSD pins, (Fig 21). If the fault condition persists, the protection circuit stays in shutdown until the fault is removed.



## Over-Current Protection (OCP)

### Low-Side Current Sensing

The low-side current sensing feature protects the low side DirectFET from an overload condition from negative load current by measuring drain-to-source voltage across  $R_{DS(ON)}$  during its on state. OCP shuts down the switching operation if the drain-to-source voltage exceeds a preset trip level.

The voltage setting on the OCSET pin programs the threshold for low-side over-current sensing. When the VS voltage becomes higher than the OCSET voltage during low-side conduction, the IRS2053 turns the outputs off and pulls CSD down to -VSS.

### High-Side Current Sensing

The high-side current sensing protects the high side DirectFET from an overload condition from positive load current by measuring drain-to-source voltage across  $R_{DS(ON)}$  during its on state. OCP shuts down the switching operation if the drain-to-source voltage exceeds a preset trip level.

High-side over-current sensing monitors drain-to-source voltage of the high-side DirectFET during the on state through the CSH and VS pins. The CSH pin detects the drain voltage with reference to the VS pin, which is the source of the high-side DirectFET. In contrast to the low-side current sensing, the threshold of the CSH pin to trigger OC protection is internally fixed at 1.2V. An external resistive divider R15, R16 and R17 are used to program a threshold as shown in Fig 20. An external reverse blocking diode D1 is required to block high voltage feeding into the CSH pin during low-side conduction. By subtracting a forward voltage drop of 0.6V at D1, the minimum threshold which can be set for the high-side is 0.6V across the drain-to-source.

## Over-Voltage Protection (OVP)

OVP is provided externally to the IRS2053M. OVP shuts down the amplifier if the bus voltage between GND and -B exceeds 39V. The threshold is determined by a Zener diode Z3. OVP protects the board from harmful excessive supply voltages, such as due to bus pumping at very low frequency-continuous output in stereo mode.

## Under-Voltage Protection (UVP)

UVP is provided externally to the IRS2053M. UVP prevents unwanted audible noise output from unstable PWM operation during power up and down. UVP shuts down the amplifier if the bus voltage between GND and -B falls below a voltage set by Zener diode Z4.

### Offset Null (DC Offset) Adjustment

The IRAUDAMP11 requires no output-offset adjustment. DC offsets are tested to be less than  $\pm 20$  mV.

### Over-Temperature Protection (OTP)

A Preset Thermostat IC, IC6 in Fig 19, is placed in close proximity to the heatsink which has 6 DirectFETs under it; and monitors heatsink temperature. If the heatsink temperature rises above 100 °C, the OTP shuts down all 3 channels by pulling down the CSD pins of the IRS2053M. OTP recovers once the temperature has cooled down.

### Click and POP Noise Reduction

Thanks to the click and pop elimination function built into the IRS2053M, the IRAUDAMP11 does not require any additional components for this function.

### Power Supply Requirements

For convenience, the IRAUDAMP11 has all the necessary housekeeping power supplies onboard and only requires a pair of symmetric power supplies. Or use the IRAUDPS1 reference design which is a 12 volt systems Audio Power Supply for automotive applications designed to provide voltage rails (+B and -B) for Class D audio power amplifiers .

### House Keeping Power Supply

The internally-generated housekeeping power supplies include  $\pm 5$ V for analog signal processing, and +12V supply ( $V_{CC}$ ) referred to the negative supply rail -B for DirectFET gate drive. The gate driver section of the IRS2053M uses  $V_{CC}$  to drive gates of the DirectFETs.  $V_{CC}$  is referenced to -B (negative power supply). D2, R18 and C10 form a bootstrap floating supply for the HO gate driver.

### Bus Pumping

When the IRAUDAMP11 is running in stereo mode, the bus pumping effect takes place with low frequency, high output. Since the energy flowing in the Class D switching stage is bi-directional, there is a period where the Class D amplifier feeds energy back to the power supply. The majority of the energy flowing back to the supply is from the energy stored in the inductor in the output LPF.

Usually, the power supply has no way to absorb the energy coming back from the load. Consequently the bus voltage is pumped up, creating bus voltage fluctuations.

Following conditions make bus pumping worse:

1. Lower output frequencies (bus-pumping duration is longer per half cycle)
2. Higher power output voltage and/or lower load impedance (more energy transfers between supplies)
3. Smaller bus capacitance (the same energy will cause a larger voltage increase)

The OVP protects IRAUDAMP11 from failure in case of excessive bus pumping. One of the easiest counter measures of bus pumping is to drive both of the channels in a stereo configuration out-of-phase so that one channel consumes the energy flow from the other and does not return it to the power supply. Bus voltage detection monitors only +B supply, assuming the bus pumping on the supplies is symmetric in +B and -B supplies.

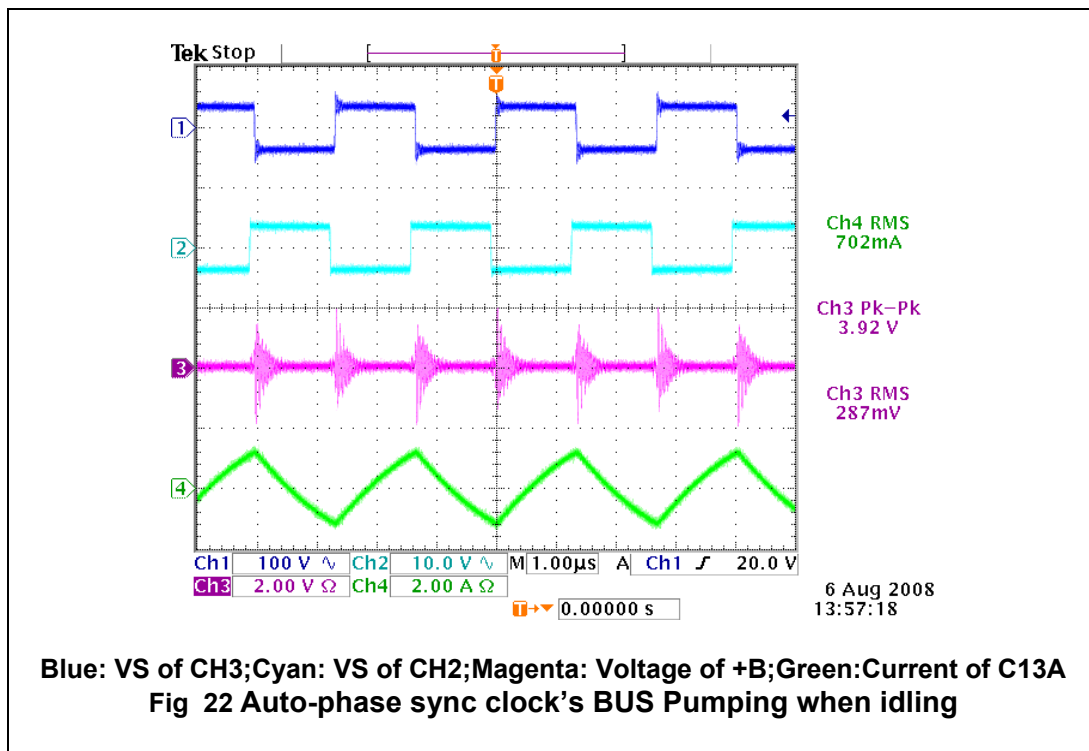

## Load Impedance

Each channel is optimized for a 4  $\Omega$  speaker load in half bridge.

## Input Signal and Gain Setting

A proper input signal is an analog signal ranging from 20Hz to 20kHz with up to 3 V<sub>RMS</sub> amplitude with a source impedance of no more than 600  $\Omega$ . Input signal with frequencies from 30kHz to 60kHz may cause LC resonance in the output LPF, causing a large reactive current flowing through the switching stage, especially with greater than 8  $\Omega$  load impedances, and the LC resonance can activate OCP.

The IRAUDAMP11 has an RC network called a Zobel network (R21 and C14) to damp the resonance and prevent peaking frequency response with light loading impedance. (Fig 23)

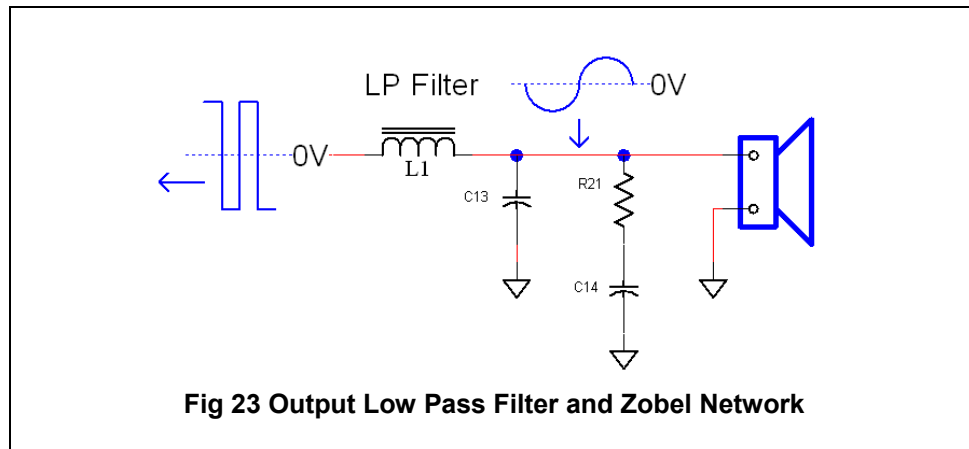

## Gain Setting

The ratio of resistors R4A~C/R1A~C in Fig 24 sets voltage gain. The IRAUDAMP11 has no on board volume control. To change the voltage gain, change the input resistor term R1A~C. Changing R4A~C affects PWM control loop design and may result poor audio performance.

**Schematic**

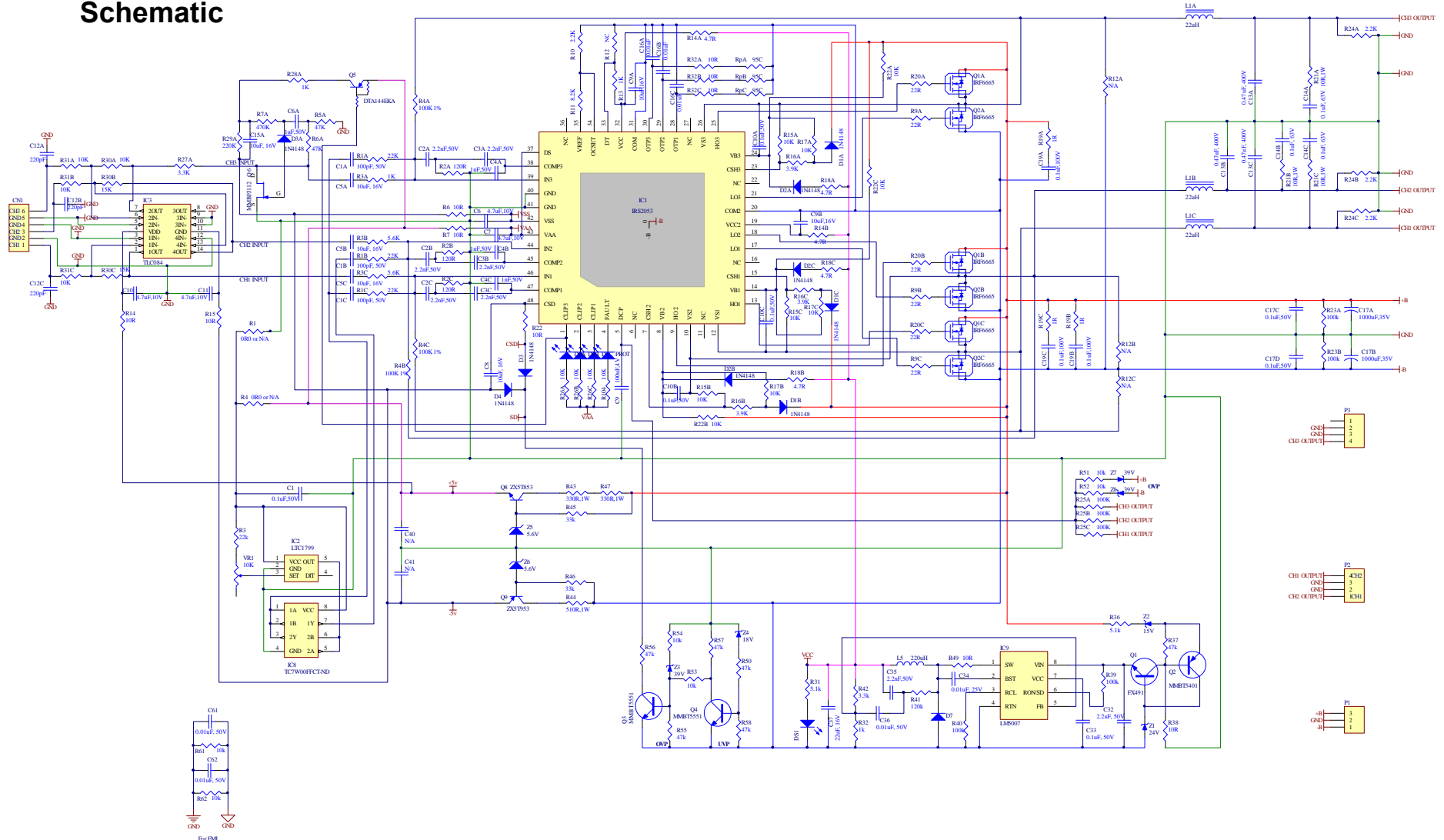

**Fig 24 IRAUDAMP11 Schematic**

## IRAUDAMP11 Fabrication Materials

Table 1 IRAUDAMP11 Electrical Bill of Materials

Quantity	Value	Description	Designator	Part Number	Vender
1	0.1uF,50V	CAP CER .1UF 50V 10% X7R 0603	C1	490-1519-1-ND	Murata Electronics North America
3	100pF, 50V	CAP CERAMIC 100PF 50V NP0 0603	C1A, C1B, C1C	399-1061-1-ND	Kemet
7	2.2nF,50V	CAP CER 2200PF 50V 10% X7R 0603	C2A, C2B, C2C, C3A, C3B, C3C, C35	490-1500-1-ND	Murata Electronics North America
3	1nF,50V	CAP 1000PF 50V CERAMICX7R 0603	C4A, C4B, C4C	399-1082-1-ND	Kemet
3	10uF, 16V	CAP 10UF 16V HA ELECT SMD	C5A, C5B, C5C	PCE4179CT-ND	Panasonic - ECG
4	4.7uF,10V	CAP CERM 4.7UF 10V Y5V 0805	C6, C7, C10, C11	478-1429-1-ND	AVX Corporation
1	1uF,50V	CAP CER 1UF 50V X7R 0805	C6A	490-4736-1-ND	Murata Electronics North America
2	10uF, 16V	CAP CER 10UF 16V X7R 20% 1206	C8, C15A	445-1601-1-ND	TDK Corporation
1	100uF,4V	CAP 100UF 4V ELECT WX SMD	C9	493-2079-1-ND	Nichicon
2	10uF,16V	CAP CER 10UF 16V Y5V 0805	C9A, C9B	490-3347-1-ND	Murata Electronics North America
3	0.1uF,50V	CAP .10UF 50V CERAMIC X7R 0805	C10A, C10B, C10C	311-1140-1-ND	Yageo
3	220pF	CAP CER 220PF 50V 10% X7R 0603	C12A, C12B, C12C	490-1483-1-ND	Murata Electronics North America
3	0.47uF, 400V	CAP .47UF 400V METAL POLYPRO	C13A, C13B, C13C	495-1315-ND	EPCOS Inc
3	0.1uF, 63V	CAP FILM MKP .1UF 63VDC 2%	C14A, C14B, C14C	BC2054-ND	Vishay/BC Components
4	0.01uF, 25V	CAP 10000PF 25V CERM X7R 0603	C16A, C16B, C16C,C34	PCC1763CT-ND	Panasonic - ECG
2	1000uF,35V	CAP 1000UF 35V ELECT SMG RAD	C17A, C17B	565-1086-ND	United Chemi-Con
2	0.1uF,50V	CAP .10UF 50V CERAMIC X7R 1206	C17C, C17D	399-1249-1-ND	Kemet
3	0.1uF,100V	CAP CER .10UF 100V X7R 10% 0805	C19A, C19B, C19C	445-1418-1-ND	TDK Corporation
1	2.2uF, 50V	CAP CER 2.2UF 50V X7R 1206	C32	490-3367-1-ND	Murata Electronics North America
1	0.1uF, 50V	CAP CER .1UF 50V 10% X7R 0805	C33	490-1666-1-ND	Murata Electronics North America
1	0.01uF, 50V	CAP CER 10000PF 50V 20% X7R 0603	C36	490-1511-1-ND	Murata Electronics North America
1	22uF, 16V	CAP CER 22UF 16V X7R 1210	C37	445-3945-1-ND	TDK Corporation
2	N/A		C40, C41	N/A	
2	0.01uF, 50V	CAP 10000PF 50V CERAMIC X7R 0603	C61, C62	399-1091-1-ND	Kemet
1	Header 6	TERMINAL BLOCK 3.5MM 6POS PCB	CN1	ED1518-ND	On Shore Technology Inc
9	1N4148	DIODE SWITCH 100V 400MW SOD-123	D1A, D1B, D1C, D2A, D2B, D2C, D3, D3A, D4	1N4148W-FDICT-ND	Diodes Inc
1	DIODE1	DIODE SCHOTTKY 100V 1.5A SMA	D7	10MQ100NPBFCT-ND	Vishay/Semiconductors
4	BLUE LED	LED 468NM BLUE CLEAR 0603 SMD	DS1, DSA, DSB, DSC	160-1646-1-ND	Lite-On Inc
1	IRS2053	3ch Audio Class D Controller	IC1	IR2053MPBF	International Rectifier
1	LTC1799	IC OSCILLATOR RES SET TSOT23-5	IC2	LTC1799CS5#TRMPBFCT-ND	Linear Technology
1	TLC084	IC OPAMP GP 10MHZ QUAD 14SOIC	IC3	296-7287-1-ND	Texas Instruments

1	TC7W00FFCT-ND	IC GATE NAND DUAL 2INPUT 8-SOP	IC8	TC7W00FFCT-ND	Toshiba National Semiconductor
1	LM5007	IC BUCK ADJ .5A 8LLP	IC9	LM5007SDCT-ND	Toshiba National Semiconductor
3	22uH	Class D inductor, 22uH	L1A, L1B, L1C	7G14A-220M-B	Inductors, Inc.
1	220uH	POWER INDUCTOR 220UH 0.49A SMD	L5	308-1538-1-ND	SUMIDA AMERICA COMPONENTS INC
1	Header 3	CONN TERM BLOCK PCB 5.0MM 3POS	P1	281-1415-ND	Weidmuller
2	SP OUT	TERMINAL BLOCK 3.5MM 4POS PCB	P2, P3	ED1516-ND	On Shore Technology Inc
1	RED LED	LED RED CLEAR 0603 SMD	PROT	160-1181-1-ND	Lite-On Inc
1	FX491	TRANS HP NPN 60V 1000MA SOT23-3	Q1	FMMT491CT-ND	Diodes/Zetex
6	IRF6665	MOSFET N-CH 100V 4.2A DIRECTFET	Q1A, Q1B, Q1C, Q2A, Q2B, Q2C	IRF6665	International Rectifier
1	MMBT5401	TRANS PNP 150V 350MW SMD SOT23-3	Q2	MMBT5401-FDICT-ND	Diodes Inc
2	MMBT5551	TRANS NPN 160V 350MW SMD SOT23-3	Q3, Q4	MMBT5551-FDICT-ND	Diodes Inc
1	DTA144EKA	TRAN DIGITL PNP 50V 30MA SOT-346	Q5	DTA144EKAT146CT-ND	Rohm Semiconductor
1	MMBFJ112	IC SWITCH ANALOG N-CH SOT-23	Q6	MMBFJ112CT-ND	Fairchild Semiconductor
1	ZX5T853	TRANSISTOR 4.5A 100V SOT-89	Q8	ZX5T853ZCT-ND	Diodes/Zetex
1	ZX5T953	TRANSISTOR PNP 3.5A 100V SOT-89	Q9	ZX5T953ZCT-ND	Diodes/Zetex
1	0R0	RES 0.0 OHM 1/10W 0603 SMD	R1	P0.0GCT-ND	Panasonic - ECG
4	22K	RES 22K OHM 1/10W 5% 0603 SMD	R1A, R1B, R1C, R3	RHM22KGCT-ND	Rohm Semiconductor
3	120R	RES 120 OHM 1/10W 5% 0603 SMD	R2A, R2B, R2C	RHM120GCT-ND	Rohm Semiconductor
3	1K	RES 1.0K OHM 1/10W 5% 0603 SMD	R3A, R13, R32	RHM1.0KGCT-ND	Rohm Semiconductor
2	5.6K	RES 5.6K OHM 1/10W 5% 0603 SMD	R3B, R3C	RHM5.6KGCT-ND	Rohm Semiconductor
3	100K 1%	RES 100K OHM 1/8W 1% 0805 SMD	R4A, R4B, R4C	RHM100KCRCT-ND	Rohm Semiconductor
8	47K	RES 47K OHM 1/10W 5% 0603 SMD	R5A, R6A, R37, R50, R55, R56, R57, R58	RHM47KGCT-ND	Rohm Semiconductor
10	10R	RES 10 OHM 1/10W 5% 0603 SMD	R6, R7, R14, R15, R22, R32A, R32B, R32C, R38, R49	RHM10GCT-ND	Rohm Semiconductor
1	470K	RES 470K OHM 1/10W 5% 0603 SMD	R7A	RHM470KGCT-ND	Rohm Semiconductor
6	22R	RES 22 OHM 1/10W 5% 0603 SMD	R9A, R9B, R9C, R20A, R20B, R20C	RHM22GCT-ND	Rohm Semiconductor
1	2.2K	RES 2.2K OHM 1/10W 5% 0603 SMD	R10	RHM2.2KGCT-ND	Rohm Semiconductor
1	8.2K	RES 8.2K OHM 1/10W 5% 0603 SMD	R11	RHM8.2KGCT-ND	Rohm Semiconductor
1	NC		R12	N/A	
3	N/A		R12A, R12B, R12C	N/A	
5	4.7R	RES 4.7 OHM 1/10W 5% 0603 SMD	R14A, R14B, R18A, R18B, R18C	RHM4.7GCT-ND	Rohm Semiconductor
25	10K	RES 10K OHM 1/10W 5% 0603 SMD	R15A, R15B, R15C, R17A, R17B, R17C, R22A, R22B, R22C, R28A, R29A, R30A, R31A, R31B, R31C, R51, R52,	RHM10KGCT-ND	Rohm Semiconductor

			R53, R54, R61, R62, R104, R26A, R26B, R26C		
3	3.9K	RES 3.9K OHM 1/10W 5% 0603 SMD	R16A, R16B, R16C	RHM3.9KGCT-ND	Rohm Semiconductor
3	1R	RES 1.0 OHM 1/8W 5% 0805 SMD	R19A, R19B, R19C	RHM1.0ARCT-ND	Rohm Semiconductor
3	10R,1W	RES 10 OHM 1W 1% 2512 SMD	R21A, R21B, R21C	PT10AECT-ND	Panasonic - ECG
7	100k	RES 100K OHM 1/10W 5% 0603 SMD	R23A, R23B, R25A, R25B, R25C, R39, R40	RHM100KGCT-ND	Rohm Semiconductor
3	2.2K	RES 2.2K OHM 1/8W 5% 0805 SMD	R24A, R24B, R24C	RHM2.2KARCT-ND	Rohm Semiconductor
2	3.3K	RES 3.3K OHM 1/10W 5% 0603 SMD	R27A, R42	RHM3.3KGCT-ND	Rohm Semiconductor
2	15K	RES 15K OHM 1/10W 5% 0603 SMD	R30B, R30C	RHM15KGCT-ND	Rohm Semiconductor
1	5.1k	RES 5.1K OHM 1/8W 5% 0805 SMD	R31	RHM5.1KARCT-ND	Rohm Semiconductor
1	5.1k	RES 5.1K OHM 1/10W 5% 0603 SMD	R36	RHM5.1KGCT-ND	Rohm Semiconductor
1	120k	RES 120K OHM 1/10W 5% 0603 SMD	R41	RHM120KGCT-ND	Rohm Semiconductor
2	330R,1W	RES 330 OHM 1W 5% 2512 SMD	R43, R47	PT330XCT-ND	Panasonic - ECG
1	510R,1W	RES 510 OHM 1W 5% 2512 SMD	R44	PT510XCT-ND	Panasonic - ECG
2	33k	RES 33K OHM 1/10W 5% 0603 SMD	R45, R46	RHM33KGCT-ND	Rohm Semiconductor
3	95C	THERMISTOR PTC 470 OHM 95C SMD	RpA, RpB, RpC	490-2465-1-ND	Murata Electronics North America
1	10K	TRIM POT ST-32TB 10 KOHMS	VR1	ST32ETB103CT-ND	Vishay/BC Components
1	24V	DIODE ZENER 24V 500MW SOD-123	Z1	BZT52C24-FDICT-ND	Diodes Inc
1	15V	DIODE ZENER 15V 500MW SOD-123	Z2	BZT52C15-FDICT-ND	Diodes Inc
3	39V	DIODE ZENER 39V 500MW SOD-123	Z3, Z7, Z8	BZT52C39-FDICT-ND	Diodes Inc
1	18V	DIODE ZENER 18V 500MW SOD-123	Z4	BZT52C18-FDICT-ND	Diodes Inc
2	5.6V	DIODE ZENER 5.6V 500MW SOD-123	Z5, Z6	MMSZ5V6T1GOSCT-ND	ON Semiconductor

**Table 2 IRAUDAMP11 Mechanical Bill of Materials**

Quantity	Value	Description	Designator	Digikey P/N	Vendor
7	Washer #4 SS	WASHER LOCK INTERNAL #4 SS	Lock washer 1, Lock washer 2, Lock washer 3, Lock washer 4, Lock washer 5, Lock washer 6 Lock washer 7	H729-ND	Building Fasteners
1	PCB	Print Circuit Board IRAUDAM11 Rev 3.0 .PCB	PCB 1		Custom
7	Screw 4-40X5/16	SCREW MACHINE PHILLIPS 4-40X5/16	Screw 1, Screw 2, Screw 3, Screw 4, Screw 5, Screw 6, Screw 7,	H343-ND	Building Fasteners
4	Stand off 0.5"	STANDOFF HEX 4-40THR .500"L ALUM	Stand Off 1, Stand Off 2, Stand Off 3, Stand Off 4	1893K-ND	Keystone Electronics
1/16	AAVID 4880G	THERMAL PAD .080" 4X4" GAPPAD	thermal pad under heatsink	BER164-ND	Thermal-alloy

IRAUDAMP11 Hardware

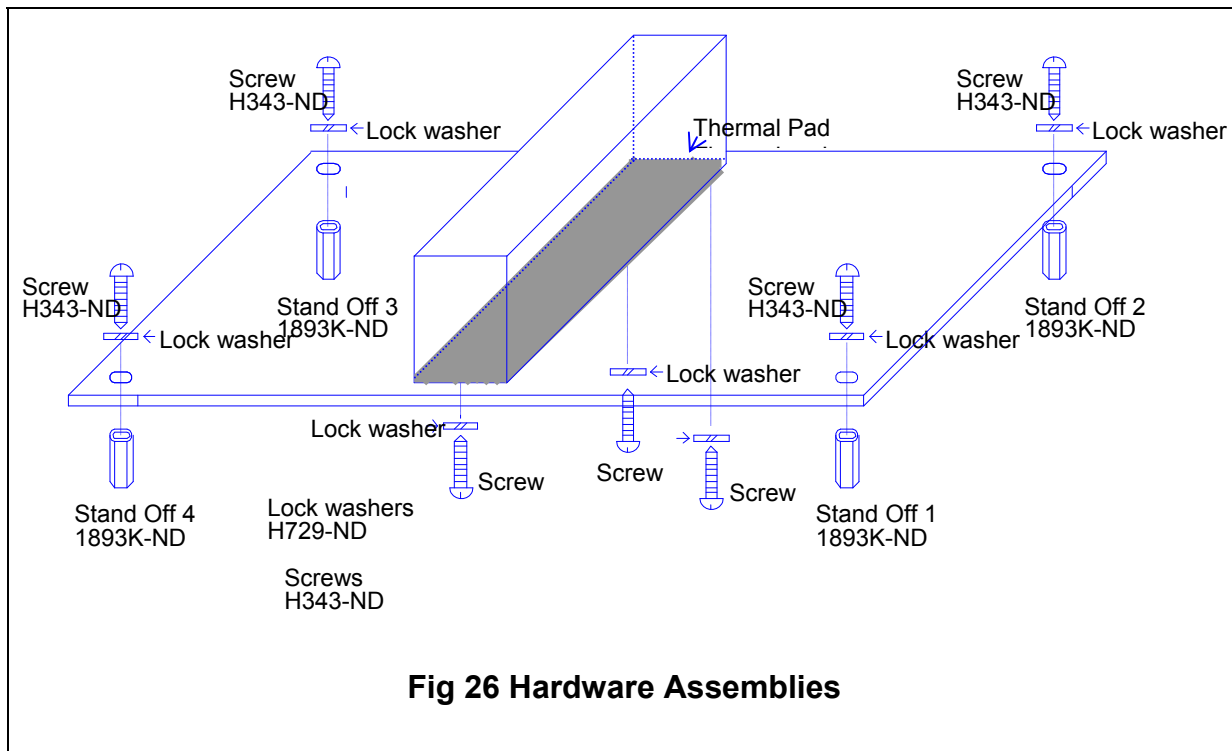
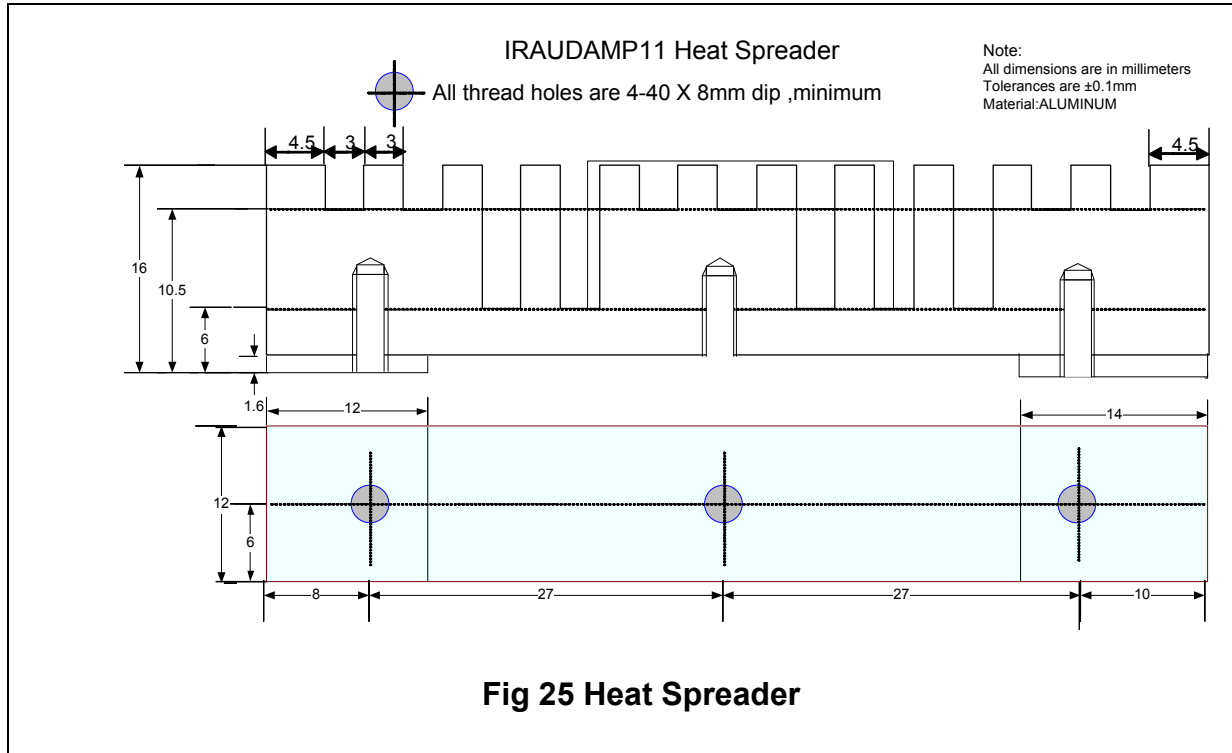

## IRAUDAMP11 PCB Specifications

PCB:

1. Two Layers SMT PCB with through holes
2. 1/16 thickness
3. 2/0 OZ Cu
4. FR4 material
5. 10 mil lines and spaces
6. Solder Mask to be Green enamel EMP110 DBG (CARAPACE) or Enthone Endplate DSR-3241 or equivalent.
7. Silk Screen to be white epoxy non conductive per IPC-RB 276 Standard.
8. All exposed copper must finished with TIN-LEAD Sn 60 or 63 for 100u inches thick.
9. Tolerance of PCB size shall be 0.010 -0.000 inches
10. Tolerance of all Holes is  $-.000 + 0.003$ "
11. PCB acceptance criteria as defined for class II PCB'S standards.

Gerber Files Apertures Description:

All Gerber files stored in the attached CD-ROM were generated from Protel Altium Designer Altium Designer 6. Each file name extension means the following:

1. .gtl Top copper, top side
2. .gbl Bottom copper, bottom side
3. .gto Top silk screen
4. .gbo Bottom silk screen
5. .gts Top Solder Mask
6. .gbs Bottom Solder Mask
7. .gko Keep Out,
8. .gm1 Mechanical1
9. .gd1 Drill Drawing
10. .gg1 Drill locations
11. .txt CNC data
12. .apr Apertures data

Additional files for assembly that may not be related with Gerber files:

13. .pcb PCB file
14. .bom Bill of materials
15. .cpl Components locations
16. .sch Schematic
17. .csv Pick and Place Components
18. .net Net List
19. .bak Back up files
20. .lib PCB libraries

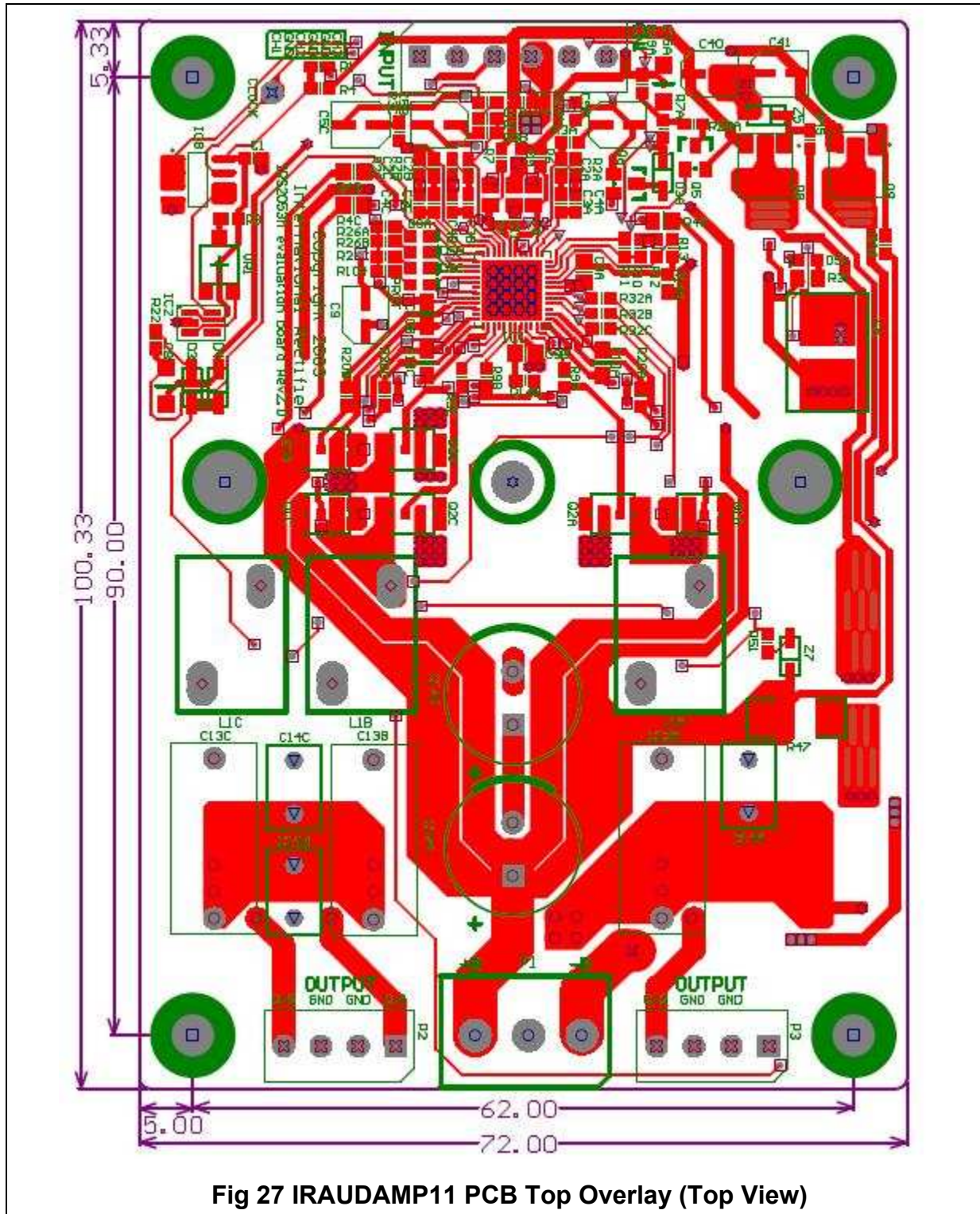
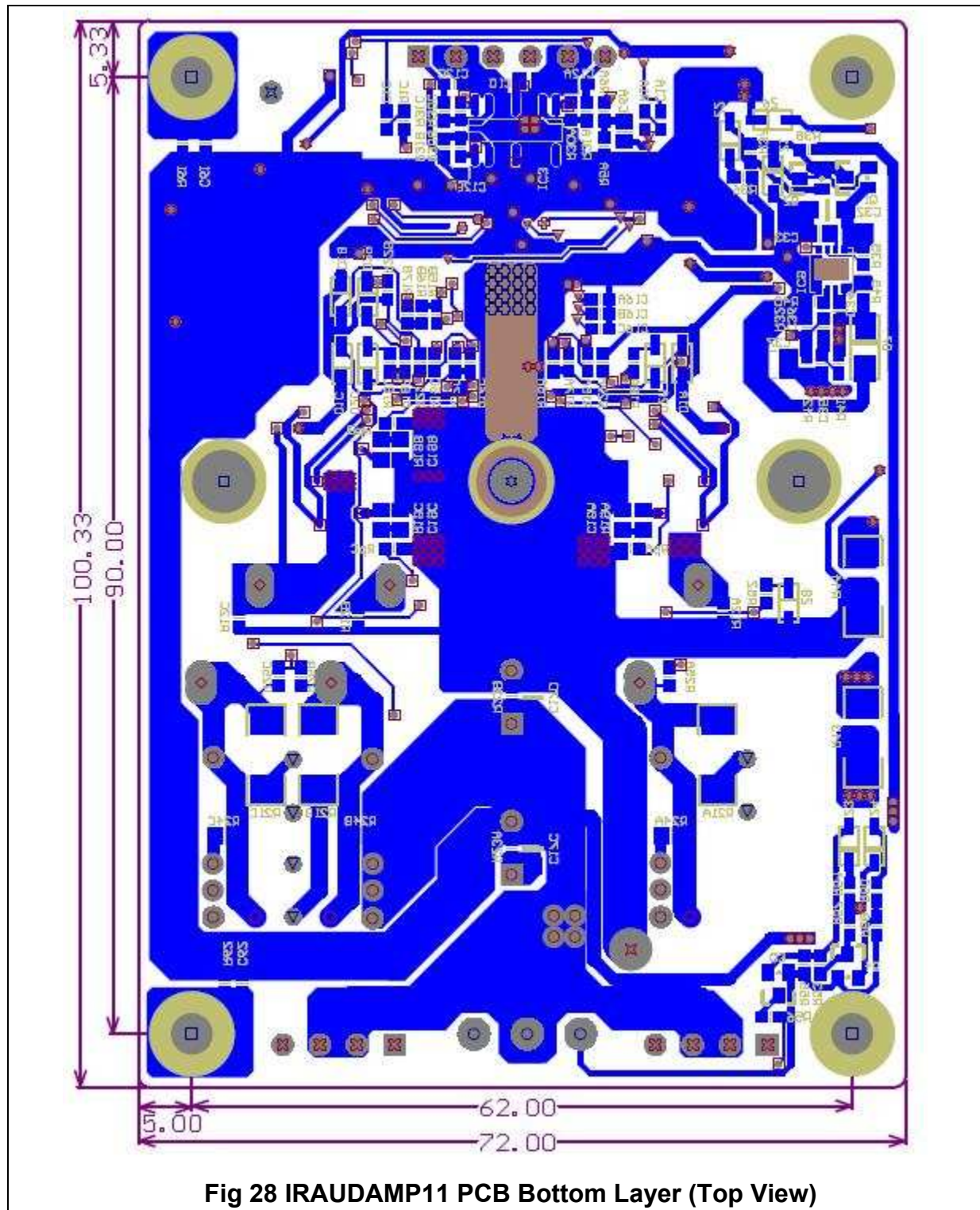

Fig 27 IRAUDAMP11 PCB Top Overlay (Top View)



## Revision changes descriptions

Revision	Changes description	Date
Rev 1.0	Released	Oct, 08 2010