

Heli-Max®



1Si Quadcopter Instruction Manual

WARNING

Please fully read and understand this manual and the operation and all safety aspects required of you for the safe operation of this product. Before use, if you feel this product is not for you please return it to your place of purchase.

Heli-Max products are to be used by ages 14 and over.

Manual Specifications and Description Changes

The instruction manual, warranties and other associated documentation is subject to change without notice. Hobbico assumes no responsibility for inadvertent errors to this manual.

Thank you for purchasing the Heli-Max 1Si Quadcopter. We are certain you will get many hours of enjoyment out of this model. If you should have any questions or concerns please feel free to contact us at: helihotline@hobbico.com. For the latest technical updates or manual corrections visit the Heli-Max web site at www.helimax-rc.com. If there is any new technical information, changes or important updates to this model a “tech notice” box will appear on the 1Si product page. Click the “tech notice” box to learn more about this important update.



When you see this symbol, please pay special attention and heed all warnings regarding the information within.

Please note that we cannot provide you information on the pricing you will find in your local retailer's store for any products.

If you need technical support or have any questions, you can reach us by one of the following means. When contacting us, please include the name of the product you are referring to, its stock number and as much information about your question or issue as possible.

For support outside the U.S. or Canada, please contact the distributor in your country. If unable to contact the appropriate distributor, please contact us. However, we are unable to respond to emails in languages other than English.

Email

Email us at helihotline@hobbico.com. Please try to include as much information as possible when asking your question. Also please be sure to list your full email address (ex: johndoe@aol.com) as well as at least one other means of daytime contact in your email.

Phone

1-217-398-8970 Select option 6. Available Monday-Friday, 8am-5pm U.S. Central Time.

Fax

1-217-398-7721 Please be sure to include a daytime telephone number or return fax number so that we can contact you.

Regular Mail

If you prefer, we can always respond with a regular mailed letter. Simply write to us, including a brief explanation of your problem or question along with the product name you are referring to. Use the Hobby Services address below.

Heli-Max guarantees this kit to be free from defects in both material and workmanship at the date of purchase. This warranty does not cover any component parts damaged by use or modification. **In no case shall Heli-Max's liability exceed the original cost of the purchased kit.** Further, Heli-Max reserves the right to change or modify this warranty without notice. In that Heli-Max has no control over the final assembly or material used for final assembly, no liability shall be assumed nor accepted for any damage resulting from the use by the user of the final user-assembled product. By the act of using the user assembled product, the user accepts all resulting liability. If the buyer is not prepared to accept the liability associated with the use of this product, the buyer is advised to return this kit immediately in new and unused condition to the place of purchase.

To make a warranty claim, **Hobby Services**
 send the defective part 3002 N. Apollo Dr., Suite 1
 or item to Hobby Services Champaign, IL 61822
 at this address. USA

Include a letter stating your name, return shipping address, as much contact information as possible (daytime telephone number, fax number, e-mail address), a detailed description of the problem and a photocopy of the purchase receipt. Upon receipt of the package the problem will be evaluated as quickly as possible.

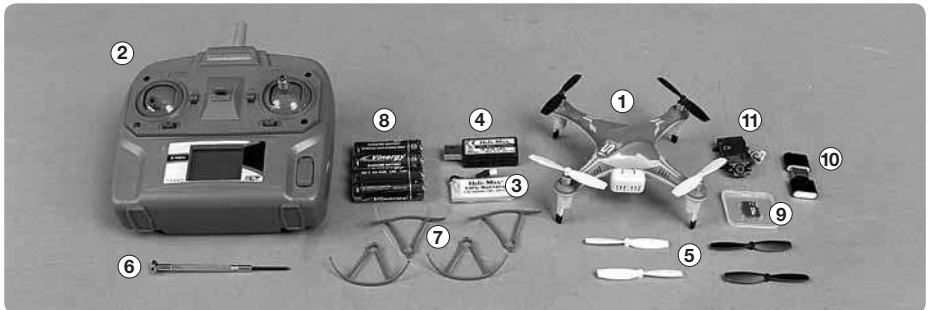

- | | | |
|---|---|---------------------------------------|
| 1. 1Si Quadcopter | 5. Extra set of blades, 2 black,
2 white | 9. 2G MicroSD card
(HMXE0832 only) |
| 2. HMX 465 SLT Transmitter | 6. Small Phillips screwdriver | 10. Card reader
(HMXE0832 only) |
| 3. Heli-Max 350mAh LiPo
Battery pack (1) | 7. 4 Blade Guards with screws,
2 gray, 2 white | 11. Camera
(HMXE0832 only) |
| 4. USB Charger | 8. AA Batteries (4) | |

Features

- Switchable TAGS-FX™ Sensor Fusion stabilization system
- On board micro digital video camera (HMXE0832 only)
- On board micro snap-shot digital picture camera (HMXE0832 only)
- USB MicroSD Card reader (HMXE0832 only)
- 2G MicroSD removable card (HMXE0832 only)
- LEDs for orientation built into frame
- Actual Direction Control flight mode
- Auto Return function
- Optional rotor blade guards

Product Specifications

Size: 125 mm (4.92") Quadcopter (Diagonal from motor center to motor center)

Motors: 20×7 Coreless (4)

Empty Weight: 31g (1.09 oz) 35g with camera

Weight RTF: 41g (1.62 oz) 45g with camera

Blade Length: 56 mm (2.20")

Overall Length: 138 mm (5.44")

Height: 45 mm (1.77")

Width: 138 mm (5.44")

Camera Specifications

Memory: Accepts MicroSD card

Size: 40 mm × 20 mm × 8 mm L×W×H

Codec Video: Motion JPEG, 1280 × 720, 30 fps, file extension .avi

Codec Audio: PCM S16 LE, mono

Still Image capture: 1280 × 720, 96 dpi, file extension .jpg

**Operational Warnings**

Failure to follow these safety precautions may result in injury to yourself and others.

- Keep your face and body as well as all spectators away from the rotating blades whenever the battery is connected.
- Keep loose clothing, shirt sleeves, ties, scarfs, long hair or loose objects such as pencils or screwdrivers that may fall out of shirt or jacket pockets

away from the rotors. The spinning blades of a model of this type can cause serious injury.

- When choosing a flying site stay clear of buildings, trees and power lines. AVOID flying in or near crowded areas.
- DO NOT fly close to people or pets. Maintain a safe distance from the quadcopter.
- Do not alter or modify the model. Doing so may result in an unsafe or un-flyable model.
- When and if repairs are necessary you must correctly install all components so that the model operates properly on the ground and in the air. Please check the operation of the model before every flight to insure that all equipment is operating and that the model has remained structurally sound.
- Please allow a 10 minute cool down period after each flight so the motor controller and motors can cool down. Failure to do so may cause loss of control due to the controller overheating and shutting down.
- Inspect the rotor blades before each flight for nicks. If any damage is found or if the blades have been damaged, replace the blades before flying the model again.
- After a crash you must inspect all plastic parts on the quadcopter for damage before attempting to fly the model again.



Battery Warnings and Usage Guidelines

Please read and understand the following regarding the usage of LiPo batteries.

- **NOTE:** Heli-Max Quadcopter battery packs are not cross compatible with Heli-Max NOVUS brand battery packs or chargers.
- Through the use of the included LiPo battery you have assumed all risk and responsibility regarding a LiPo battery and its use.
- ALWAYS unplug your battery from either the charger or Quadcopter after use. NEVER store your Quadcopter with the battery plugged into the Quadcopter.
- Do not attempt to charge your battery if it becomes swollen or hot.
- It's best to store your batteries charged and at room temperature. Storing a fully discharged battery may cause irreversible damage to the battery.
- Never disassemble, puncture or modify the battery pack in anyway.
- Never allow the battery temperature to exceed 150° F [65° C].
- If your battery begins to swell or “puff” during charge or discharge or becomes damaged in any way, stop using it and contact Hobby Services at 217-398-0007 to learn the proper way to dispose of your battery.





Charge Warnings

- Only use the included charger with the included LiPo battery. Do not attempt to use the provided charger with NiCd, NiMH or batteries with other chemistries.
- Do not leave the charger unattended while in use and always charge your battery in a fire-resistant location.
- Disconnect the battery and remove input power from the charger immediately if either becomes hot!
- Do not allow water or other foreign objects to enter the charger. Keep the charger away from moisture and do not submerge in water.
- Please keep all electronic components out of the reach of children!



● **WARNING!!** The charger supplied with the Heli-Max 1Si Quadcopter contains protective circuitry. If you experience any difficulties while charging the battery, please disconnect the battery from the charger and unplug the charger from the power source. Allow the battery and charger to rest for two hours as this will allow the charge protection circuit to reset. If this issue re-occurs during normal use, please contact technical support for further assistance.

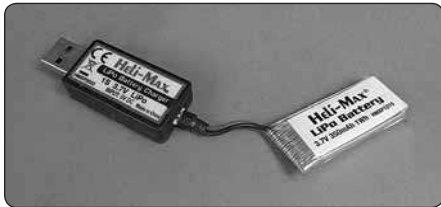

Plug the flight battery into the end of the USB charger.



Plug charger into a USB port. A steady red light will glow letting you know the battery is charging. The light will flash slowly when the charge is complete. Remove the battery from the charger. Under normal operating conditions, the battery may take up to 60 minutes to recharge. Never leave the battery attached to the charger after charging is complete.

NOTE: A fast flash indicates a charge error. This is usually an indication that your battery is defective and should be replaced.

Transmitter Setup



❑ Install 4 AA batteries in the transmitter by removing the battery cover from the back of the transmitter. Double-check the polarity of each battery before replacing the battery cover.

❑ Turn the Transmitter on and make sure that there is a blue light behind the Heli-Max panel at the top of the transmitter. The LCD screen should be on, with a throttle position indicator and other information.



❑ Make sure the electronic trim indicators on the display are centered.

Heli-Max[®] TRANSMITTER CONTROLS

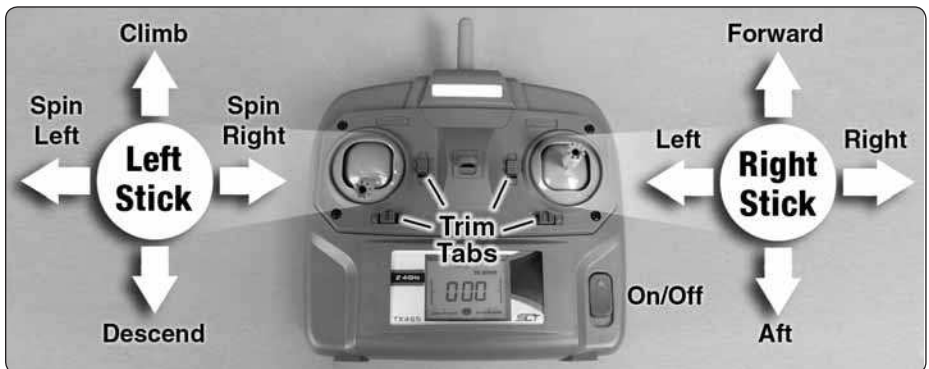

All controls are described with the tail pointing directly toward you. This is the best way to fly in the beginning since it keeps the control inputs oriented the same direction.

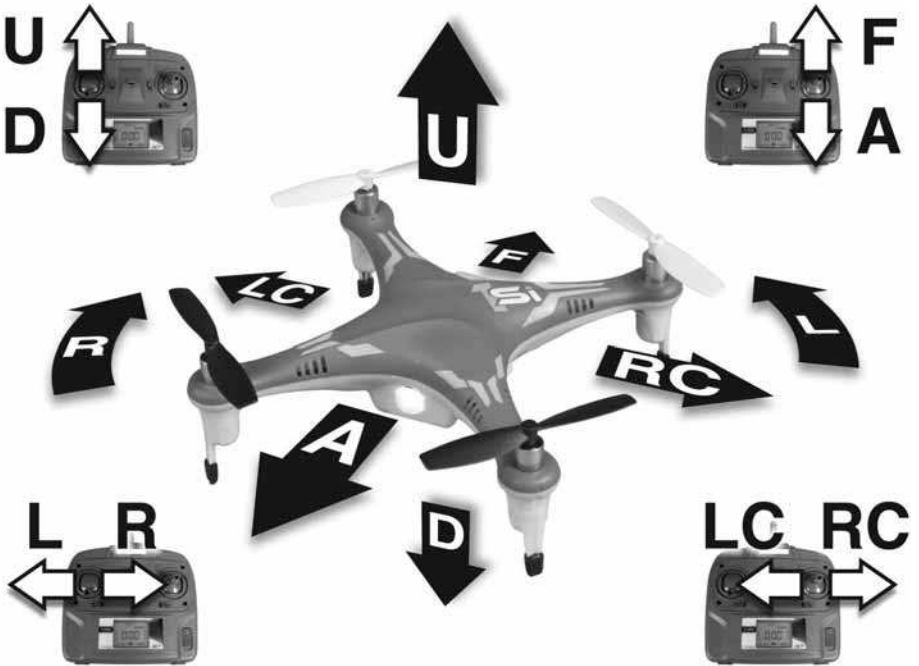
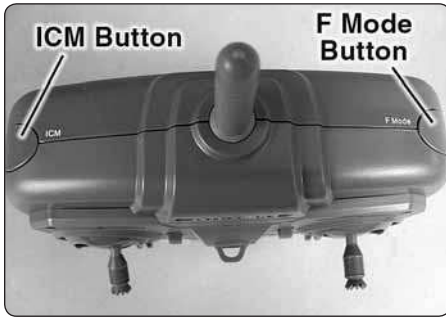

Heli-MAX®

INSTALLING THE BLADE GUARDS

Installing the optional rotor blade guards is recommended. Besides protecting the rotor blades from damage, these parts can also allow the 1Si to continue to fly if it brushes up against a wall or other solid object.

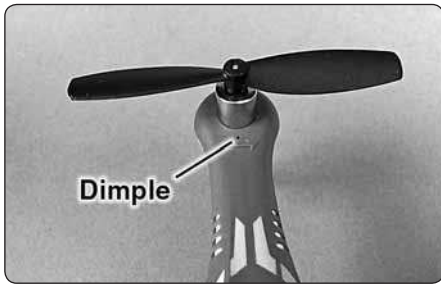

□ Slide the guard over the motor and position the hole for the mounting screw over the dimple on the top of the arm.

□ Secure the guard to the frame with the included screw.

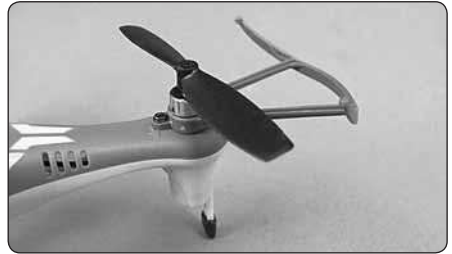

Heli-MAX[®] **FLYING YOUR 1Si QUADCOPTER**



Electric motors are very dangerous. Do not work on the model while the flight battery is plugged in as interference may cause the main rotor blades to spin, possibly causing injury.



Turn on the transmitter and lay it down so the antenna is pointed at the LED on the back of the 1Si as shown in the photo. Connect the flight battery to the quadcopter. Do not move the 1Si or the transmitter until the LED stops flashing and is steady. This procedure will help the 1Si to maintain the correct orientation while in flight or returning to home position.

NOTE: The 1Si will be “ON” at this point. Your quadcopter has a safe start feature built in that prevents the motor from activating unless the throttle stick has been lowered to the lowest position. If the motors won’t run, please make sure the throttle stick is all the way down and the throttle trim is at or below center. Wait a couple of seconds and try advancing the throttle again.

Takeoff

Advance the throttle until the model is at least a foot off the ground and out of ground effect. If flying outdoors it’s important to stick to light winds. If you plan to take off and land in grass, place a rubber mat or pad down on the grass so the small rotating parts don’t get hung up in the grass.

Hovering

Once the quad is in the air simply try to keep it in one spot. This will take some practice. Remember that even a light breeze will have an effect on the stability of the quad.

Landing

Level the quad into a steady hover and slowly decrease power until it lands. You might notice as the Quadcopter is ready to touch down it moves around a little. This is normal as the Quadcopter enters ground effect.



Once you are comfortable with hovering in one place start working on orientations. By this we mean, hover the Quadcopter in all positions, nose to the right, nose to the left and the nose pointing at you (nose-in). Getting good at this fundamental discipline will allow you to progress much faster in some of the more advanced flying maneuvers.

Slow Pirouettes

Move the left stick (left or right) you can rotate the Quadcopter around 360°, which is called a pirouette.

Forward Flight

Now it's time to work into basic forward flight. Just take the basic hovering maneuvers listed above and slowly fly out farther and faster and always bring the Quadcopter back after one pass. Practice controlled slow flight in close as well. The more time you spend practicing here, the easier things will be later on.



Before turning off the transmitter, make sure that all the trim indicators on the transmitter are centered. If you find that the model is consistently drifting in one direction, the sensors on the 1Si may need to be re-calibrated (see Troubleshooting).

Remove the battery from the 1Si. Allow it cool to room temperature and recharge it. Do not leave the battery connected to the 1Si after the flight is completed.

If the model is to be stored for a long time period, please remove the batteries from the transmitter to avoid damage to the contacts. If storing the model for several weeks, the batteries for the quadcopter should be charged to 50% of a full charge and checked after 3 to 4 months.

Heli-MAX® **FLIGHT MODE OPTIONS**



Dual Rate

The TX465 transmitter has a dual rate function. This feature toggles between a flight mode that reduces the model's range of motion to make the 1Si easier to fly and one that allows the full range of motion so the 1Si can fly in a more aggressive manner. To toggle between these two flight modes, press down on the right control stick and release

it. When the transmitter is in low rates, the ellipse in the lower center of the LCD screen will show a half ellipse and emit a single low pitch single beep. For high rates, the ellipse will be complete and the transmitter will emit a single high pitch beep.

Flight Control Sensitivity

You can also make the transmitter for the 1Si more or less sensitive by changing the control setting. To do this, press and hold the right stick down. When the transmitter starts to beep continuously, move the throttle up or down to adjust the sensitivity percentage which will be indicated on the LCD screen. A higher value will make the controls more sensitive. When you have the desired setting, release the right stick and return the throttle to 0%. We have found that 30% is good all-around setting. Warning: If this value gets bumped to 0 your quadcopter will respond very slowly to any right stick input.

Beginner/Expert Mode

When the 1si is turned on it will be in Beginner Mode. In this mode, the control board will apply "Braking" to slow the 1Si and bring the model to a hover when the right sticks are released. The quad will be very smooth and stable in this mode.

Press the "F Mode" button on the upper right corner of the transmitter to enter the Expert Mode. The LED on the back of the 1Si will flash twice, stay off for a second, flash twice again, and then remain on. When the quadcopter is in this mode, the accelerometers are disabled and the 1Si will not slow down when the right stick is centered. This mode also will allow the 1Si to fly more aggressively.

To return to the normal flight mode, press the “F Mode” button again. The rear LED will flash twice, stay on for a second, flash twice again, and then remain steady. This sequence indicates that the accelerometers and the Braking function are active again.

Actual Direction Control

When the “ICM” button on the upper left corner of the transmitter is pressed for at least 3 seconds, the 1Si will enter the “Actual Direction Control” flight mode and the LED on the back of quadcopter will flash slowly. In this mode, the 1Si will use the pilot’s position as a reference point for any signal received from the right stick on the transmitter. Moving stick forward or backward will move the quadcopter farther or close to the pilot. The direction that the front of the 1Si is facing will not have any effect while in this mode. The antenna on the transmitter must be pointed at the quadcopter at all times to help the model maintain its position while in flight.

To exit the “Actual Direction Control” mode, press the ICM button again for 3 seconds. The rear LED will become steady to indicate that it is now in the normal flight mode.



Adjustment Mode

The 1Si will have to be put in the Adjustment Mode before any adjustments to the return speed or the sensors can be performed.

1. Turn on the transmitter and connect the battery to the quad so it can link. Keep the antenna pointed at the LED on the 1Si until the linking process is completed.

2. Press down on the right stick and hold. Continue to hold down the right stick until the next step is completed.

3. Press down the left stick 4 times and then release both sticks. Push up on the elevator trim button once and release it. At the same time, watch the display for a change on the elevator trim indicator. If the indicator does not move, the transmitter and 1Si are in the Adjustment Mode. Note: Pressing down on the left stick at any time will cause the transmitter to exit the Adjustment Mode.

Auto Return

To make the 1Si return to you, press the ICM on the upper left corner of the transmitter quickly and release it. The rear LED will flash quickly and model will start to fly toward the transmitter. The pilot can use the throttle to control the altitude, but any movement with the right stick will cause the model to return to the normal flight mode. When the model gets close, the pilot should expect to use the transmitter to slow the 1Si and bring it to a hover. **Note:** The transmitter antenna should point at the quadcopter at all times to help keep the 1Si on course.

This procedure should be used if the return speed of the 1Si needs to be changed.

1. Enter the Adjustment Mode as described earlier.
2. Push the rudder trim button to the left increase the return speed. The longer the button is held to the left, the LED on the 1Si will flash faster and the tone will increase in pitch to indicate that a higher return speed is being selected. When the LED remains steady, the highest speed has been selected. Moving the button to the right will reduce the return speed. The LED will flash slower and the pitch will be lower to indicate the speed that is being selected. When the LED turns off, the lowest speed has been selected.
3. Press down on the left stick to exit the Adjustment Mode when the desired speed has been selected.

Heli-Max[®] ***CAMERA OPERATION***

The camera will be in VIDEO mode when it is first powered up. Press the VIDEO button to start recording a video. You will see the LED on the side of the camera flash slowly while the video is being captured. To stop recording and store the video, press the VIDEO button again. The LED will stop flashing to indicate that the camera is ready for use. If the card is removed or the battery unplugged while the camera is recording, the video will NOT be saved on the card.

Before the camera can take a photo, it must be in the Picture mode. Press the PICTURE button one time, to change the mode. The LED on the camera will remain steady while the camera mode is changed. Press the PICTURE button to take a photo. You will notice that the LED will flash rapidly as the picture is recorded and stored on the microSD card. When the LED stops flashing, the camera is ready to take another photo. If the Picture button is pressed while the LED is flashing, the camera will not capture another photo. The VIDEO button must be pressed once to change modes before the camera will capture a video.

Installing the MicroSD Card

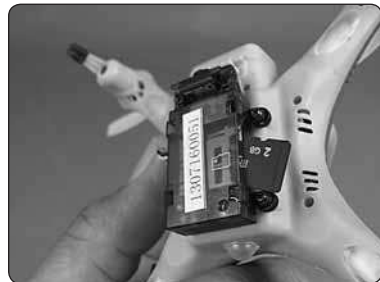

To minimize any chance of data being lost on the microSD card, do not insert or remove the card from the camera until the battery has been unplugged from the quadcopter. Remove the SD card from the protective case. Flip the model over and push the card into the slot on the side of the camera module. When the card is correctly installed, it will click. To remove the card, simply press

on the card again and the inner spring system will help eject the card. Note: The card must be in place to capture video or Pictures. The camera has no internal memory.

Downloading the video and pictures from the camera:

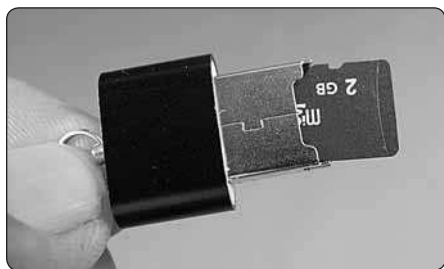

Install the MicroSD card into the reader. Plug the reader into the USB port of your computer.

The USB connection will be auto recognized and the files ready to be transferred.

At this point you can copy or transfer your files to your folder structure.



PROBLEM: 1Si does not react to any stick movements.

Solution 1: Make sure that the battery voltage is above 4.0 volts

Solution 2: If the LED on the rear of the model is not steady, unplug the battery and turn off the transmitter to allow the control board to reset itself. After about a minute, turn on the transmitter and reconnect the battery.

PROBLEM: Flies with poor power or buzzes.

Solution: One of the props may be bent. Carefully bend it straight.

PROBLEM: You notice that one of the motors spins noticeably slower or feels tight.

Solution: Replace the motor. This is done by removing all 4 props and loosening the screws holding the frame together. Remove the top of the frame and unplug the defective motor wire from the control board. The LED board can be popped off the alignment posts with a small screwdriver. The motor will slide out of the frame and the new motor/ LED board can now be installed. A couple of small pieces of tape will hold the LED board in place.

PROBLEM: The 1Si will not return directly to you in Auto Return mode.

Solution: Calibrate the transmitter and or the control board.

Control Board Sensor Calibration

1. Enter the Adjustment Mode as described on page 12.
2. Press up on the throttle trim button and the rear LED on the 1Si will start flashing rapidly.
3. When the LED stops flashing, press down on the left stick to exit.

If you still have problems, try the tip on page 17.

Transmitter Calibration

Press on the ICM button while turning on the transmitter. The display will show a "1" briefly then display a "2".

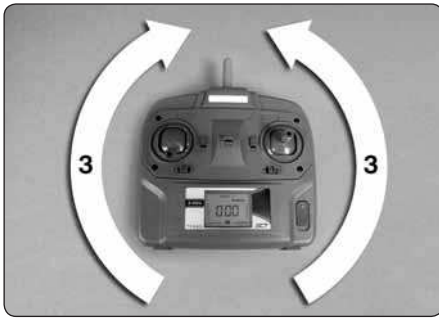

Place the transmitter down on its back with the antenna pointed away from you. Slowly rotate the transmitter clockwise three times, then three times counter-clockwise.

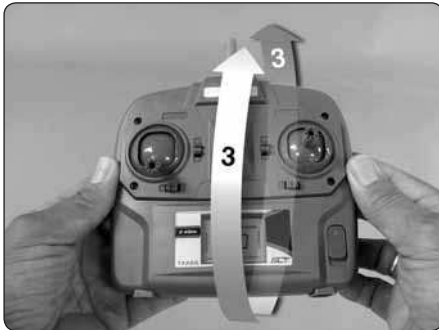

Pick the transmitter up by the sides and rotate it so the antenna moves toward you. Rotate it three times, then three more times in the opposite direction.



Hold the transmitter by the antenna and bottom with antenna pointed away from you. Rotate the transmitter left to right three times. Rotate it three more times from right to left.

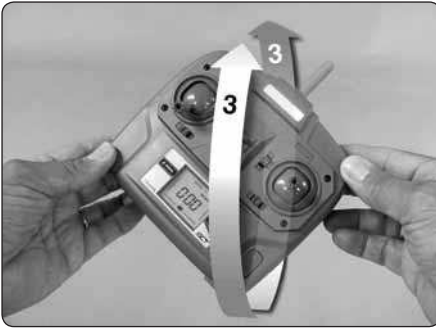

Hold the transmitter by the upper right corner and lower left corner so the antenna is pointed 45 degrees to the right. Rotate the transmitter three times with the antenna moving toward you, then three more times in the opposite direction.

Put the transmitter down with the antenna pointed away from you and push the ICM button. The display should read "0".

Press the F Mode button. The display will indicate 90 and the transmitter should be rotated so the antenna is at 90 degrees. Each time the F Mode button is pressed, the display will increase 90 degrees and the transmitter should be rotated to that position before the button is pressed again. When the display reads "0", press the F Mode button to exit the calibration mode.

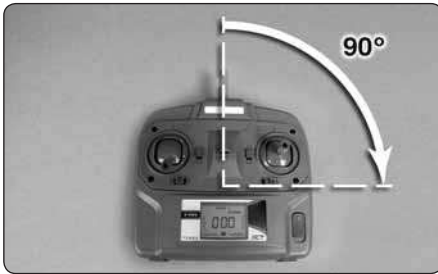

This procedure will usually correct problems with the Auto Return or Actual Direction Control modes. If you continue to have problems, please try the model in another area. There may be some interference in your flying location that is affecting the sensors.

REAR LED CODES	
THIS SIGNAL	MEANS THAT THE
1 Long, 3 Short, Off, 1 Long, 3 Short ...	Control board is not linked with transmitter
Steady	1Si is ready for flight
1 Short, Off (rapidly flashing)	Auto Return mode is active
1 Long, Off (slowly flashing)	Active Direction Control mode is active
2 Short, Off, 2 Short, Remains ON	1Si is changing to Manual Flight mode
2 Short, 1 Long, 2 Short, Remains On	1Si is changing to Normal Flight mode

PROBLEM: The Camera System will not take a photo or start recording a video.

Solution 1: Install the microSD card if it is not in the slot.

Solution 2: Eject the card and check for any debris on the contacts.

Solution 3: Make sure card is OK by putting the card in reader and checking on your PC.

PROBLEM: 1Si drifts while hovering.

Solution: Use the following procedure to re-calibrate the neutral setting on the 1Si.

1. Enter the Adjustment mode as described on page 12.
2. The quadcopter should be hovered about 3 feet above the floor in a calm area without any wind or drafts. Release both sticks for a second or two and observe the 1Si's behavior. If the quadcopter drifts forward or backward, move the elevator trim in the opposite direction until the model remains in place. Use the aileron trim below the right stick in the same manner to correct for any drifting side to side.
3. Press down on the left stick to exit the Adjustment mode when the quadcopter has been trimmed.

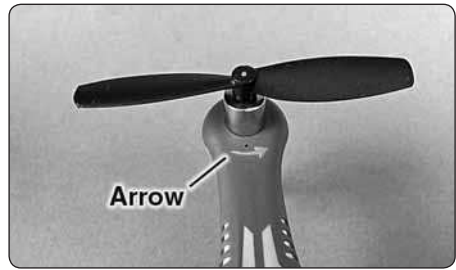

When installing the rotor blades on the 1Si, please use this photo as a guide. There is also an arrow molded on the frame to show the direction the rotor blades will spin.

Key	Part No.	Description
1	HMXE2203	Blade Guard (4)
2	HMXE2202	Rotor Blades Black / White
3	HMXE2244	Body / Frame Gray
4	HMXM2053	TAGS-FX Controller Board
5	HMXE2241	Motor/LED Right Front CCW 1Si
6	HMXE2240	Motor/LED Left Front CW 1Si
7	HMXE2243	Motor/LED Right Rear CW 1Si
8	HMXE2242	Motor/LED Left Rear CCW 1Si
9	HMXE2180	Control Board Dampeners
10	HMXE2245	Receiver Mount
11	HMXP1015	LiPo 1S 3.7V 350mAh
12	HMXZ0001	Video / Picture Camera
13	HMXE7339	Screw Set
14	HMXE2246	Landing Pads (4)
	HMXJ2029	TX465 Transmitter SLT
	HMXP2023	USB Charger
	HMXZ0002	USB MicroSD Reader

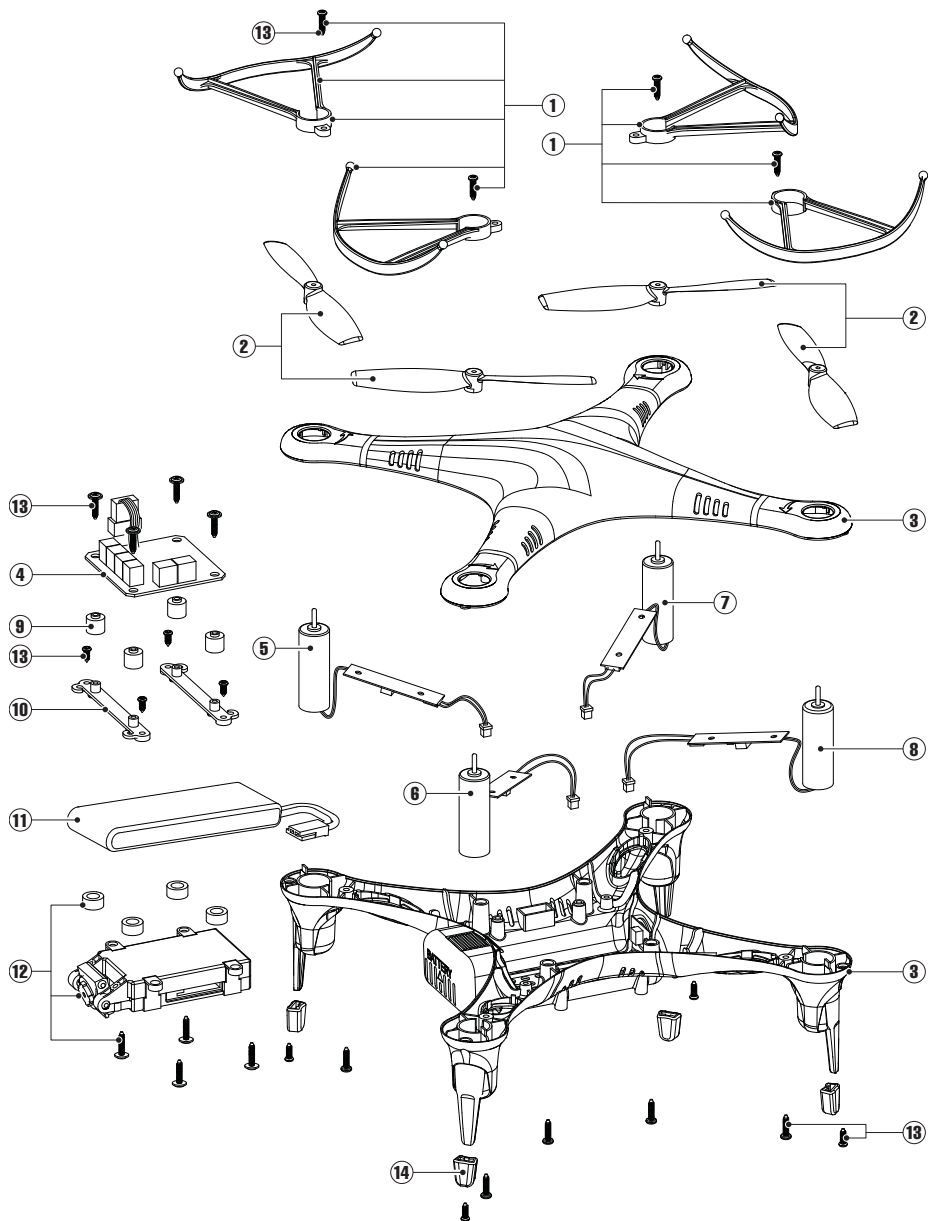

Heli-Max[®]