

## IRS21571D FULLY INTEGRATED BALLAST CONTROL IC

### IC Features

- Programmable preheat time and frequency
- Programmable ignition ramp
- Protection from failure-to-strike
- Lamp filament sensing and protection
- Protection from operation below resonance -
- 0.2V CS threshold sync'd to falling edge on LO
- Protection from low-line condition
- Automatic restart for lamp exchange
- Thermal overload protection
- Programmable deadtime
- Integrated 600V level-shifting gate driver
- Integrated bootstrap MOSFET
- Integrated 15.6V zener clamp diode on VCC
- Low micro-power start-up
- Latch immunity and ESD on all pins

### Typical Application

- Fluorescent lamp ballast

### Product Summary

Topology	Half-Bridge
$V_{\text{OFFSET}}$	600 V
$I_{\text{O+}}$ & $I_{\text{O-}}$ (typical)	180 mA & 260 mA
Oscillator Frequency	+/- 5%
Start-up current (typical)	150 $\mu\text{A}$

### Package Options



16-Lead SOIC (Narrow Body)

### Typical Connection Diagram

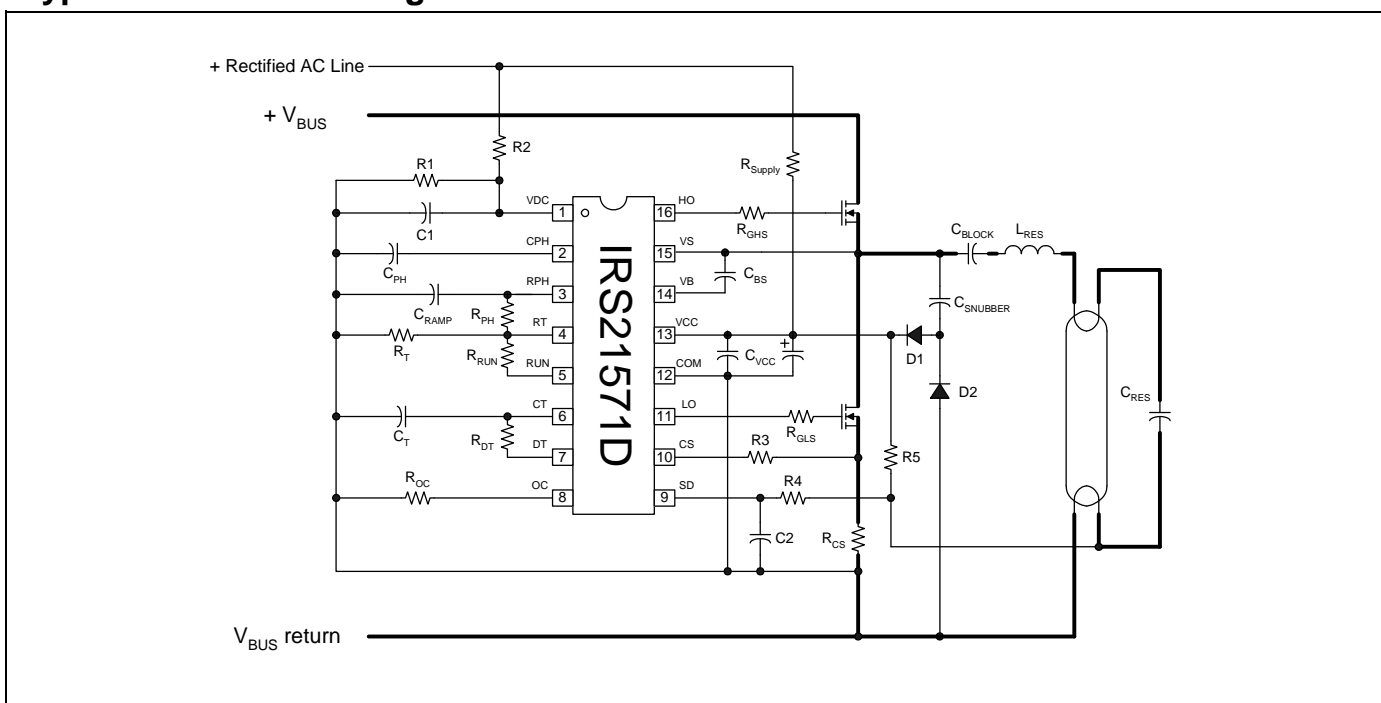



<b>Table of Contents</b>	<b>Page</b>
Typical Connection Diagram	1
Qualification Information	4
Absolute Maximum Ratings	5
Recommended Operating Conditions	6
Electrical Characteristics	7
Functional Block Diagram	9
Input/Output Pin Equivalent Circuit Diagrams	10
Lead Definitions	11
Lead Assignments	12
State Diagram	13
Application Information and Additional Details	14
Package Details	25
Part Marking Information	26
Ordering Information	27
Change History	28



## Description

The IRS21571D is a fully integrated, fully protected 600V ballast control IC designed to drive virtually all types of rapid start fluorescent lamp ballasts. Externally programmable features such as preheat time and frequency, ignition ramp characteristics, and running mode operating frequency provide a high degree of flexibility for the ballast design engineer. Comprehensive thermal overload, or lamp failure during normal operation, as well as an automatic restart function, have been included in the design. The heart of this control IC is a variable frequency, 50% duty cycle oscillator with externally programmable deadtime. An integrated bootstrap MOSFET is also included to supply the high-side gate drive circuitry. The IRS21571D is available in 16 pin narrow body SOIC package.



Qualification Information<sup>†</sup>

<b>Qualification Level</b>		Industrial <sup>††</sup>	
		Comments: This family of ICs has passed JEDEC's Industrial qualification. IR's Consumer qualification level is granted by extension of the higher Industrial level.	
<b>Moisture Sensitivity Level</b>		SOIC16N	MSL2 <sup>†††</sup> (per IPC/JEDEC J-STD-020)
<b>ESD</b>	<b>Machine Model</b>	Class C (per JEDEC standard EIA/JESD22-A115)	
	<b>Human Body Model</b>	Class 3A (per EIA/JEDEC standard JESD22-A114)	
<b>IC Latch-Up Test</b>		Class , Level A (per JESD78)	
<b>RoHS Compliant</b>		Yes	

† Qualification standards can be found at International Rectifier's web site <http://www.irf.com/>

†† Higher qualification ratings may be available should the user have such requirements. Please contact your International Rectifier sales representative for further information.

††† Higher MSL ratings may be available for the specific package types listed here. Please contact your International Rectifier sales representative for further information.



## Absolute Maximum Ratings

Absolute Maximum Ratings indicate sustained limits beyond which damage to the device may occur. All voltage parameters are absolute voltages referenced to COM, all currents are defined positive into any lead. The Thermal Resistance and Power Dissipation ratings are measured under board mounted and still air conditions.

Symbol	Definition	Min.	Max.	Units
$V_B$	High Side Floating Supply Voltage	-0.3	625	V
$V_S$	High Side Floating Supply Offset Voltage	$V_B - 25$	$V_B + 0.3$	V
$V_{HO}$	High-Side Floating Output Voltage	$V_S - 0.3$	$V_B + 0.3$	V
$V_{LO}$	Low-Side Output Voltage	-0.3	$V_{CC} + 0.3$	V
$I_{OMAX}$	Maximum Allowable Output Current (Either Output) Due to External Power Transistor Miller Effect	-500	500	mA
$I_{RT}$	RT Pin Current	-5	5	mA
$V_{CT}$	CT Pin Voltage	-0.3	5.5	V
$V_{DC}$	VDC Pin Voltage	-0.3	$V_{CC} + 0.3$	V
$I_{CPH}$	CPH Pin Current	-5	5	mA
$I_{RPH}$	RPH Pin Current	-5	5	mA
$I_{RUN}$	RUN Pin Current	-5	5	mA
$I_{DT}$	Deadtime Pin Current	-5	5	mA
$V_{CS}$	Current Sense Pin Voltage	-0.3	5.5	V
$I_{CS}$	Current Sense Pin Current	-5	5	mA
$I_{OC}$	Over-Current Threshold Pin Current	-5	5	mA
$I_{SD}$	Shutdown Pin Current	-5	5	mA
$I_{CC}$	Supply Current <sup>†</sup>	-20	20	mA
$dV/dt$	Allowable Offset Voltage Slew Rate	-50	50	V/ns
$P_D$	Package Power Dissipation @ $T_A \leq +25^\circ\text{C}$ (16-Pin DIP)	---	1.60	W
$P_D$	Package Power Dissipation @ $T_A \leq +25^\circ\text{C}$ (16-Pin SOIC)	---	1.25	W
$R_{\theta JA}$	Thermal Resistance, Junction to Ambient (16-Pin DIP)	---	75	$^\circ\text{C}/\text{W}$
$R_{\theta JA}$	Thermal Resistance, Junction to Ambient (16-Pin SOIC)	---	100	$^\circ\text{C}/\text{W}$
$T_J$	Junction Temperature	-55	150	$^\circ\text{C}$
$T_S$	Storage Temperature	-55	150	
$T_L$	Lead Temperature (Soldering, 10 seconds)	---	300	

† This IC contains a zener clamp structure between the chip  $V_{CC}$  and COM which has a nominal breakdown voltage of 15.6V. Please note that this supply pin should not be driven by a DC, low impedance power source greater than the  $V_{CLAMP}$  specified in the Electrical Characteristics section.

## Recommended Operating Conditions

For proper operation the device should be used within the recommended conditions.

Symbol	Definition	Min.	Max.	Units
$V_{BS}$	High Side Floating Supply Voltage	$V_{BSUV+}$	$V_{CLAMP}$	V
$V_S$	Steady State High Side Floating Supply Offset Voltage	-3.0	600	V
$V_{CC}$	Supply Voltage	$V_{CCUV+}$	$V_{CLAMP}$	V
$I_{CC}$	Supply Current	†	10	mA
$V_{DC}$	VDC Pin Voltage	0	$V_{CC}$	V
$C_T$	CT Pin Capacitance	220	---	pF
$R_{DT}$	Deadtime Resistance	1.0	---	k $\Omega$
$R_{OC}$	Over-Current (CS+) Threshold Programming Resistance	---	50	k $\Omega$
$I_{RT}$	$R_T$ Pin Current ††	-500	-50	$\mu$ A
$I_{RPH}$	$R_{PH}$ Pin Current ††	0	450	$\mu$ A
$I_{RUN}$	RUN Pin Current ††	0	450	$\mu$ A
$I_{SD}$	Shutdown Pin Current	-1	1	mA
$I_{CS}$	Current Sense Pin Current	-1	1	mA
$T_J$	Junction Temperature	-40	125	$^{\circ}$ C

† Enough current should be supplied into the VCC pin to keep the internal 15.6V zener clamp diode on this pin regulating its voltage.

†† Due to the fact that the RT input is a voltage-controlled current source, the total RT pin current is sum of all of the parallel current sources connected to that pin. For optimum oscillator current mirror performance, this total current should be kept between 50 $\mu$ A and 500 $\mu$ A. During the preheat mode, the total current flowing out of the RT pin consists of the RPH pin current plus the current due to the RT resistor. During the run mode, the total RT pin current consists of the RUN pin current plus the the current due to the RT resistor.

**Electrical Characteristics**

$V_{CC} = V_{BS} = V_{BIAS} = 14V \pm 0.25V$ ,  $R_T = 16.9k\Omega$ ,  $C_T = 470 pF$ ,  $R_{PH}$  and  $RUN$  pins no connection,  $V_{CPH} = 0V$ ,  $R_{DT} = 6.1 k\Omega$ ,  $R_{OC} = 20.0 k\Omega$ ,  $V_{CS} = 0.5 V$ ,  $V_{SD} = 0 V$ ,  $C_L = 1000pF$  and  $T_A = 25 \text{ }^\circ\text{C}$  unless otherwise specified.

Symbol	Definition	Min	Typ	Max	Units	Test Conditions
<b>Supply Characteristics</b>						
$V_{CCUV+}$	$V_{CC}$ Supply Undervoltage Positive Going Threshold	11.5	12.5	13.5	V	$V_{CC}$ rising from 0V
$V_{UVHYS}$	$V_{CC}$ Supply Undervoltage Lockout Hysteresis	---	2.0	---		
$I_{QCCUV}$	UVLO Mode Quiescent Current	---	150	300	$\mu A$	$V_{CC} = V_{CCUV+} - 100mV$
$I_{QCCFLT}$	Fault-Mode Quiescent Current	---	400	600		$SD = 5V$ , $CS = 2V$ , or $T_j > T_{SD}$
$I_{QCC}$	Quiescent $V_{CC}$ Supply Current		2	4.3	mA	CT connected to COM
$I_{QCC40k}$	$V_{CC}$ Supply Current, $f = 40kHz$	4.0	5.5	7.0		
$V_{CLAMP}$	$V_{CC}$ Zener Clamp Voltage	---	15.6	---	V	$I_{CC} = 5mA$
<b>Floating Supply Characteristics</b>						
$I_{QBS0}$	Quiescent $V_{BS}$ Supply Current	---	50	100	$\mu A$	$V_{HO} = V_S$
$I_{QBS1}$	Quiescent $V_{BS}$ Supply Current	---	72	140		$V_{HO} = V_B$
$V_{BSUV+}$	$V_{BS}$ Supply Undervoltage Positive Going Threshold	---	9.0	---	V	$V_{BS}$ rising from 0V
$V_{BSUV-}$	$V_{BS}$ Supply Undervoltage Negative Going Threshold	---	8.0	---		$V_{BS}$ falling from 14V
$I_{LK}$	Offset Supply Leakage Current	---	---	50	$\mu A$	$V_B = V_S = 600V$
<b>Oscillator I/O Characteristics</b>						
$f_{OSC}$	Oscillator Frequency	43.7	46	48.3	kHz	
$d$	Oscillator Duty Cycle		50			%
$V_{CT+}$	Upper $C_T$ Ramp Voltage Threshold	---	4.0	---	V	
$V_{CT-}$	Lower $C_T$ Ramp Voltage Threshold	---	2.0	---		
$V_{CTFLT}$	Fault-Mode $C_T$ Pin Voltage	---	0	---	mV	$SD = 5V$ , $CS = 2V$ , or $T_j > T_{SD}$
$V_{RT}$	$R_T$ Pin Voltage	---	2.0	---	V	
$V_{RTFLT}$	Fault-Mode $R_T$ Pin Voltage	---	0	---	mV	$SD = 5V$ , $CS = 2V$ , or $T_j > T_{SD}$
$td_{LO}$	LO Output Deadtime	---	2.3	---	$\mu sec$	
$td_{HO}$	HO Output Deadtime	---	2.3	---	$\mu sec$	
<b>Preheat Characteristics</b>						
$I_{CPH}$	CPH Pin Charging Current			0.98	$\mu A$	$V_{CPH} = 0V$
$V_{CPHIGN}$	CPH Pin Ignition Mode Threshold Voltage	3.7	4.0	4.3	V	
$V_{CPHRUN}$	CPH Pin Run Mode Threshold Voltage	4.6	5.0	5.4		
$V_{CPHFLT}$	Fault-Mode CPH Pin Voltage	---	0	---	mV	$SD = 5V$ , $CS = 2V$ , or $T_j > T_{SD}$

**Electrical Characteristics**

$V_{CC} = V_{BS} = V_{BIAS} = 14V \pm 0.25V$ ,  $R_T = 16.9k\Omega$ ,  $C_T = 470 pF$ ,  $R_{PH}$  and  $RUN$  pins no connection,  $V_{CPH} = 0V$ ,  $R_{DT} = 6.1 k\Omega$ ,  $R_{OC} = 20.0 k\Omega$ ,  $V_{CS} = 0.5 V$ ,  $V_{SD} = 0 V$ ,  $C_L = 1000pF$  and  $T_A = 25 \text{ }^\circ\text{C}$  unless otherwise specified.

Symbol	Definition	Min	Typ	Max	Units	Test Conditions
<b>RPH Characteristics</b>						
$I_{RPHLK}$	Open Circuit RPH Pin Leakage Current	---	---	0.1	$\mu A$	$V_{RPH} = 5V$ , $V_{PH} = 6V$
$V_{RPHFLT}$	Fault-Mode RPH Pin Voltage	---	---	50	mV	$SD = 5V$ , $CS = 2V$ , or $T_j > T_{SD}$
<b>RUN Characteristics</b>						
$I_{RUNLK}$	Open Circuit RUN Pin Leakage Current	---	---	0.1	$\mu A$	$V_{RUN} = 5V$
$V_{RUNFLT}$	Fault-Mode RUN Pin Voltage	---	0	---	mV	$SD = 5V$ , $CS = 2V$ , or $T_j > T_{SD}$
<b>Protection Circuitry Characteristics</b>						
$V_{SD+}$	Rising Shutdown Pin Threshold Voltage	2.0	2.2	2.4	V	
$V_{SDHYS}$	Shutdown Pin Threshold Hysteresis	270	395	520	mV	
$V_{CS+}$	Over-Current Sense Threshold Voltage	0.99	1.1	1.21	V	
$V_{CS-}$	Under-Current Sense Threshold Voltage	0.15	0.2	0.26	V	
$t_{cs}$	Over-Current Sense Propagation Delay		250	400	nsec	Delay from CS to LO
$V_{DC+}$	Low $V_{BUS}$ /Rectified Line Input Upper Threshold	5.0	5.2	5.6	V	
$V_{DC-}$	Low $V_{BUS}$ /Rectified Line Input Lower Threshold	2.8	3.1	3.4	V	
$T_{SD}$	Thermal Shutdown Junction Temperature	---	160	---	$^\circ\text{C}$	†
<b>Gate Driver Output Characteristics</b>						
$V_{OL}$	Low-Level Output Voltage		0	100	mV	$I_O = 0$
$V_{OH}$	High-Level Output Voltage		0	100		$V_{BIAS} - V_O$ , $I_O = 0$
$t_r$	Turn-On Rise Time		120	220	nsec	
$t_f$	Turn-Off Fall Time		50	220		
$I_{O+}$	Output source current	---	180	---	mA	
$I_{O-}$	Output sink current	---	260	---		

† When the IC senses an overtemperature condition ( $T_j > 175^\circ\text{C}$ ), the IC is latched off. In order to reset this Fault Latch, the SD pin must be cycled high and then low, or the  $V_{CC}$  supply to the IC must be cycled below the falling undervoltage lockout threshold ( $V_{CCUV-}$ ).

## Functional Block Diagram

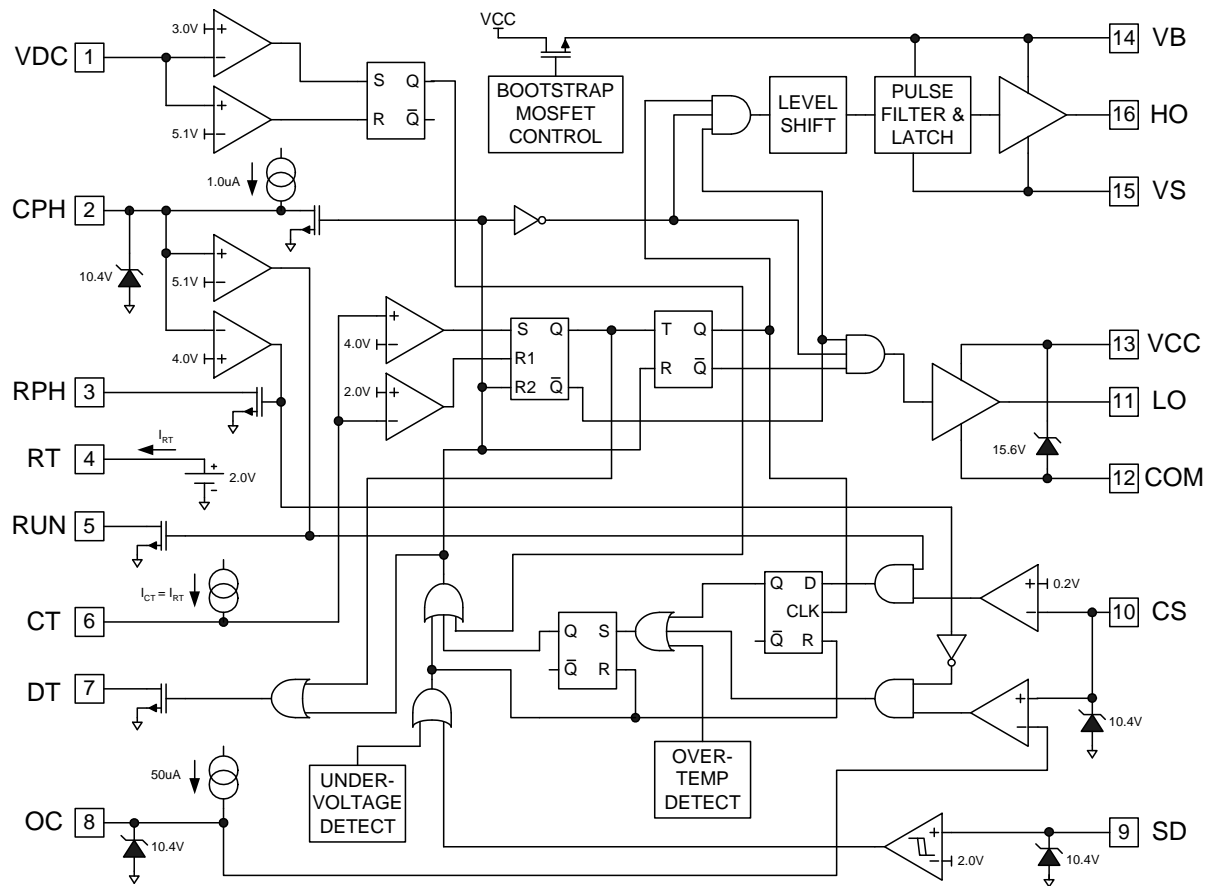

## Input/Output Pin Equivalent Circuit Diagrams

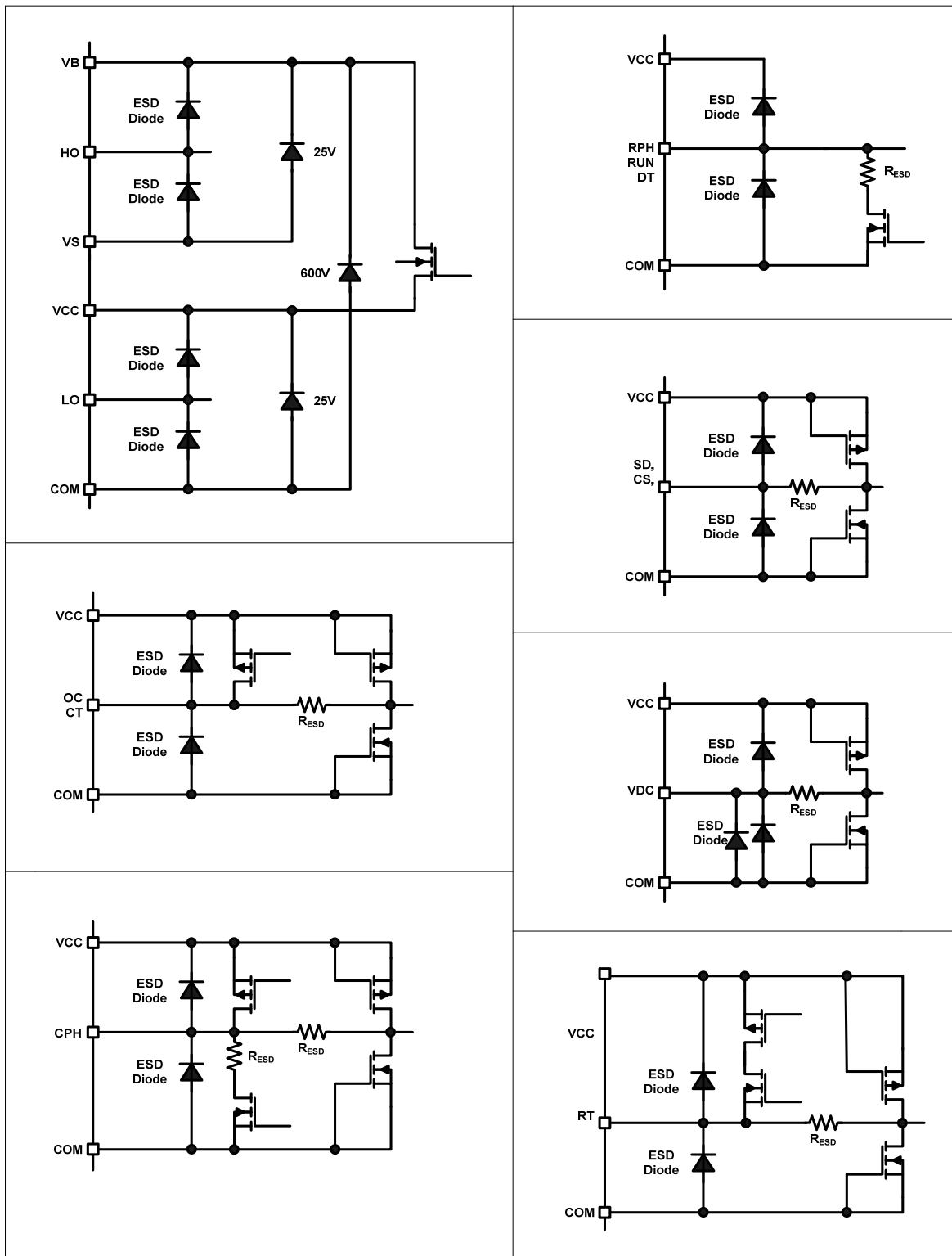



## Lead Definitions

<b>Symbol</b>	<b>Description</b>
VDC	DC Bus Sensing Input
CPH	Preheat Timing Capacitor
RPH	Preheat Frequency Resistor & Ignition Capacitor
RT	Oscillator Timing Resistor
RUN	Run Frequency Resistor
CT	Oscillator Timing Capacitor
DT	Deadtime Programming
OC	Over-current (CS+) Threshold Programming
SD	Shutdown Input
CS	Current Sensing Input
LO	Low-Side Gate Driver Output
COM	IC Power & Signal Ground
VCC	Logic & Low-side Gate Driver Floating Supply
VB	High-Side Gate Driver Floating Supply
VS	High Voltage Floating Return
HO	High-Side Gate Driver Output

## Lead Assignments

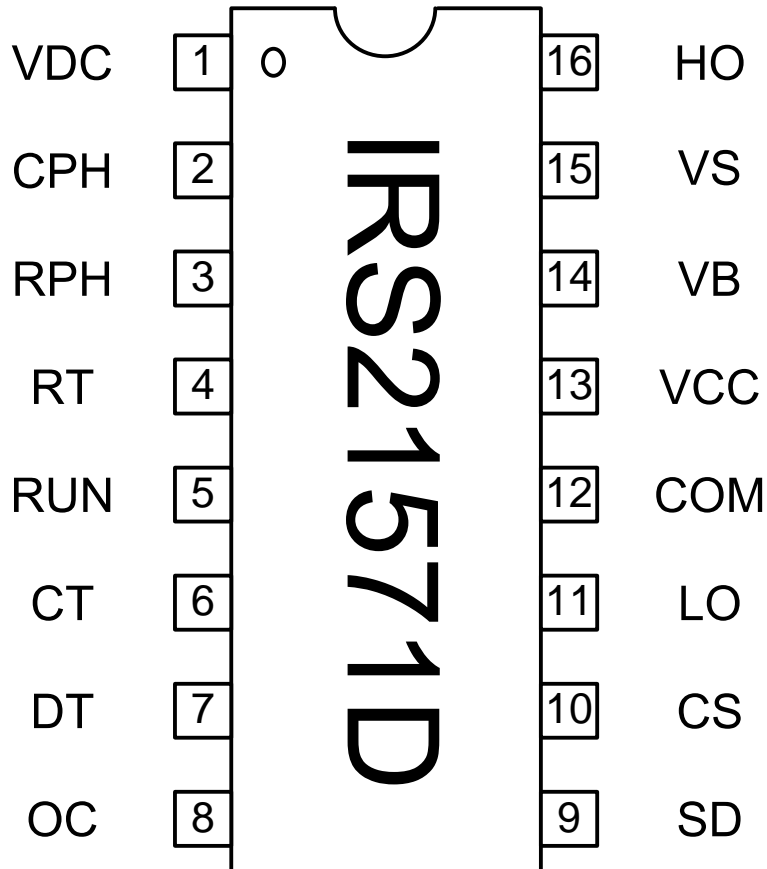

## State Diagram

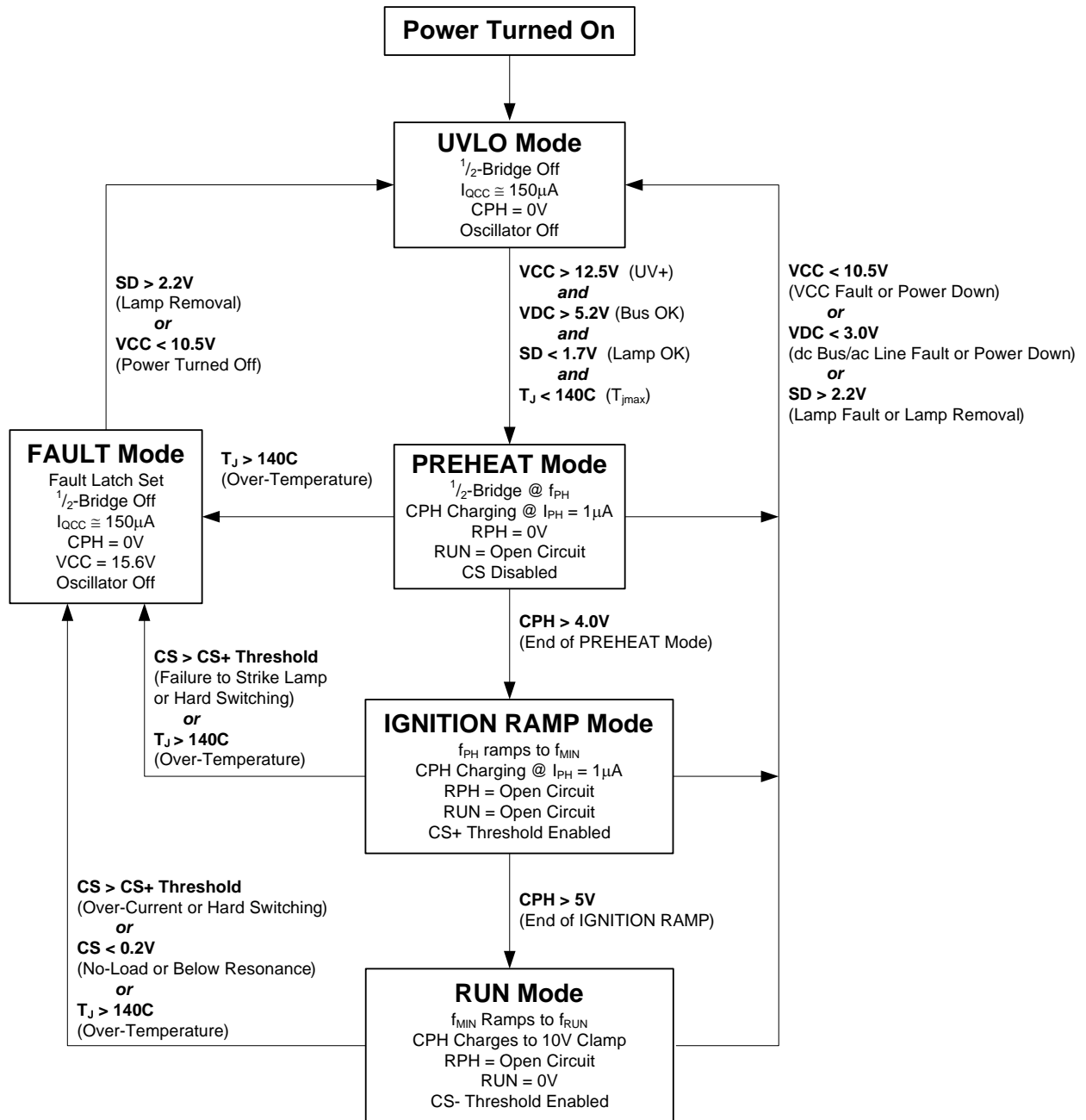

## Application Information and Additional Details

### Supply Bypassing and PCB Layout Rules

Component selection and placement on the pc board is extremely important when using power control ICs.  $V_{CC}$  should be bypassed to COM as close to the IC terminals as possible with a low ESR/ESL capacitor, as shown in Figure 1 below.

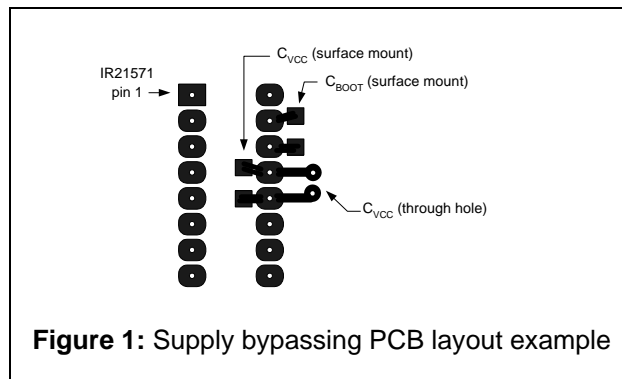

A rule of thumb for the value of this bypass capacitor is to keep its minimum value at least 2500 times the value of the total input capacitance ( $C_{iss}$ ) of the power transistors being driven. This decoupling capacitor can be split between a higher valued electrolytic type and a lower valued ceramic type connected in parallel, although a good quality electrolytic (e.g.,  $10\mu F$ ) placed immediately adjacent to the VCC and COM terminals will work well.

In a typical application circuit, the supply voltage to the IC is normally derived by means of a high value startup resistor ( $1/4W$ ) from the rectified line voltage, in combination with a charge pump from the output of the half-bridge. With this type of supply arrangement, the internal  $15.6V$  zener clamp diode from VCC to COM will determine the steady state IC supply voltage.

### Connecting the IC Ground (COM) to the Power Ground

Both the low power control circuitry and low side gate driver output stage grounds return to this pin within the IC. The COM pin should be connected to the bottom terminal of the current sense resistor in the source of the low side power MOSFET using an individual pc board trace, as shown in Figure 2. In addition, the ground return path of the timing components and  $V_{CC}$  decoupling capacitor should be connected directly to the IC COM pin, and not via separate traces or jumpers to other ground traces on the board.

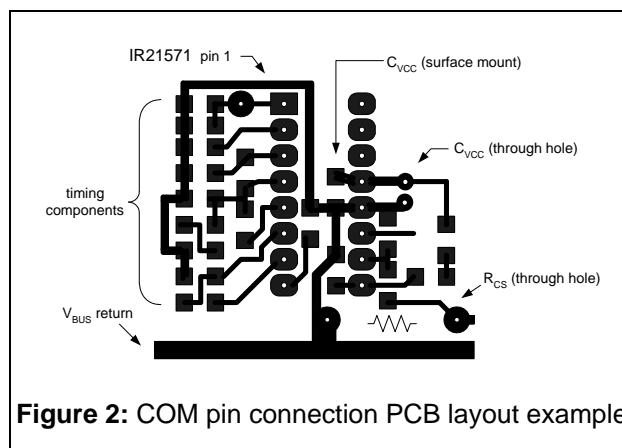

These connection techniques prevent high current ground loops from interfering with sensitive timing component operation, and allows the entire control circuit to reject common-mode noise due to output switching.

## The Control Sequence and Timing Component Selection

The IRS21571D uses the following control sequence (Figure 3) to drive rapid start fluorescent lamps.

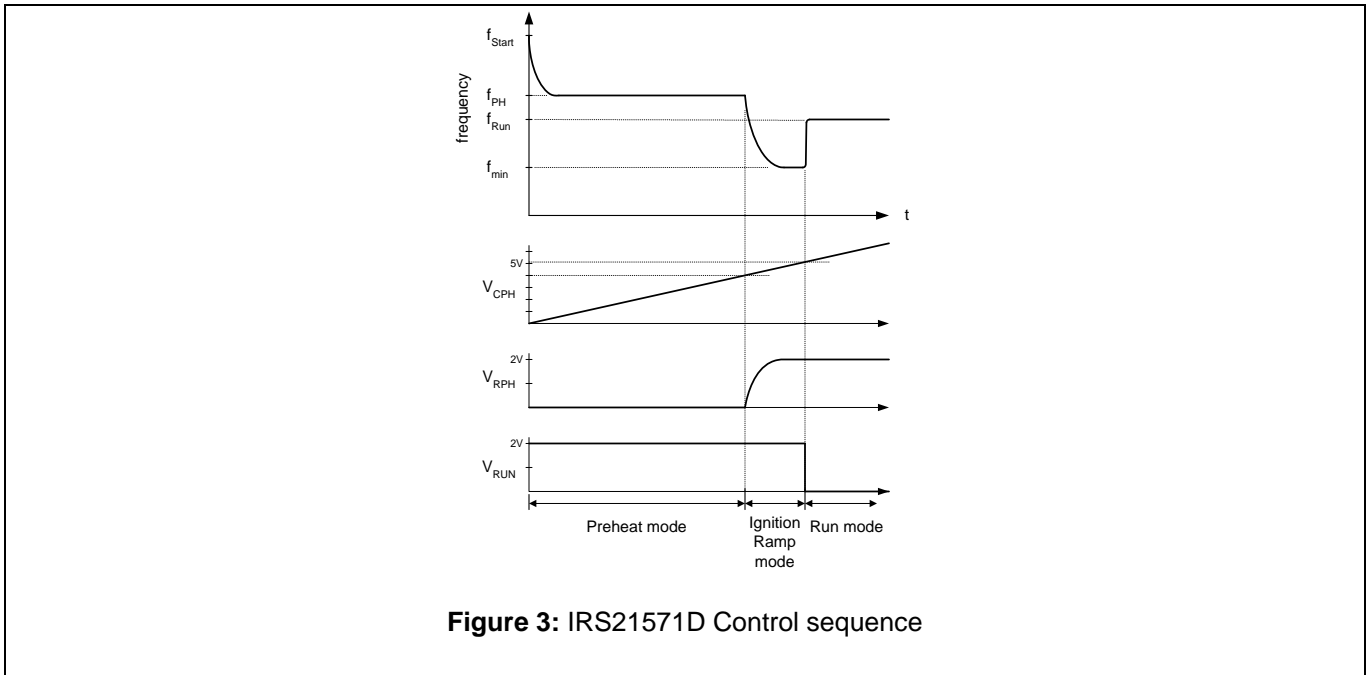
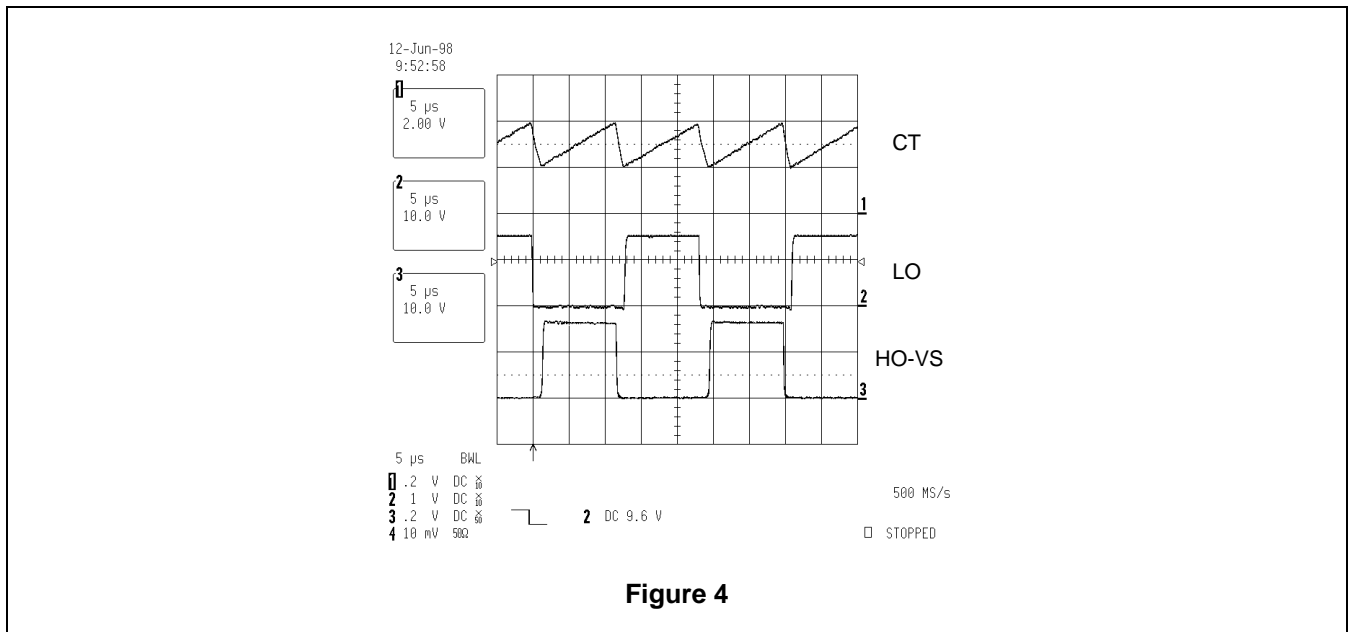

**Figure 3:** IRS21571D Control sequence

The control sequence used in the IRS21571D allows the **Run Mode** operating frequency of the ballast to be higher than the ignition frequency (i.e.,  $f_{start} > f_{ph} > f_{run} > f_{ign}$ ). This control sequence is recommended for lamp types where the ignition frequency is too close to the run frequency to ensure proper lamp striking for all production resonant LC component tolerances (please note that it is possible to use the IRS21571D in systems where  $f_{start} > f_{ph} > f_{ign} > f_{run}$ , simply by leaving the RUN pin open).

Six pins in the IC are used to control the **Startup, Preheat, Ignition Ramp, and Run** modes of operation, and to allow ballast and lamp engineers the flexibility to optimize their designs for virtually any lamp type.

The heart of this controller is an oscillator which resembles those found in many popular PWM voltage regulator ICs. In its simplest form, this oscillator consists of a timing resistor and capacitor connected to ground. The voltage across the timing capacitor  $C_T$  is a sawtooth, where the rising portion of the ramp is determined by the current in the  $R_T$  pin, and the falling portion of the ramp is determined by an external deadtime resistor  $R_{DT}$ . The oscillograph in Figure 4 illustrates the relationship between the oscillator capacitor waveform and the gate driver outputs.



The deadtime can be programmed by means of the external  $R_{DT}$  resistor, given a certain range of  $C_T$  capacitor values, using the graph shown in Figure 5.

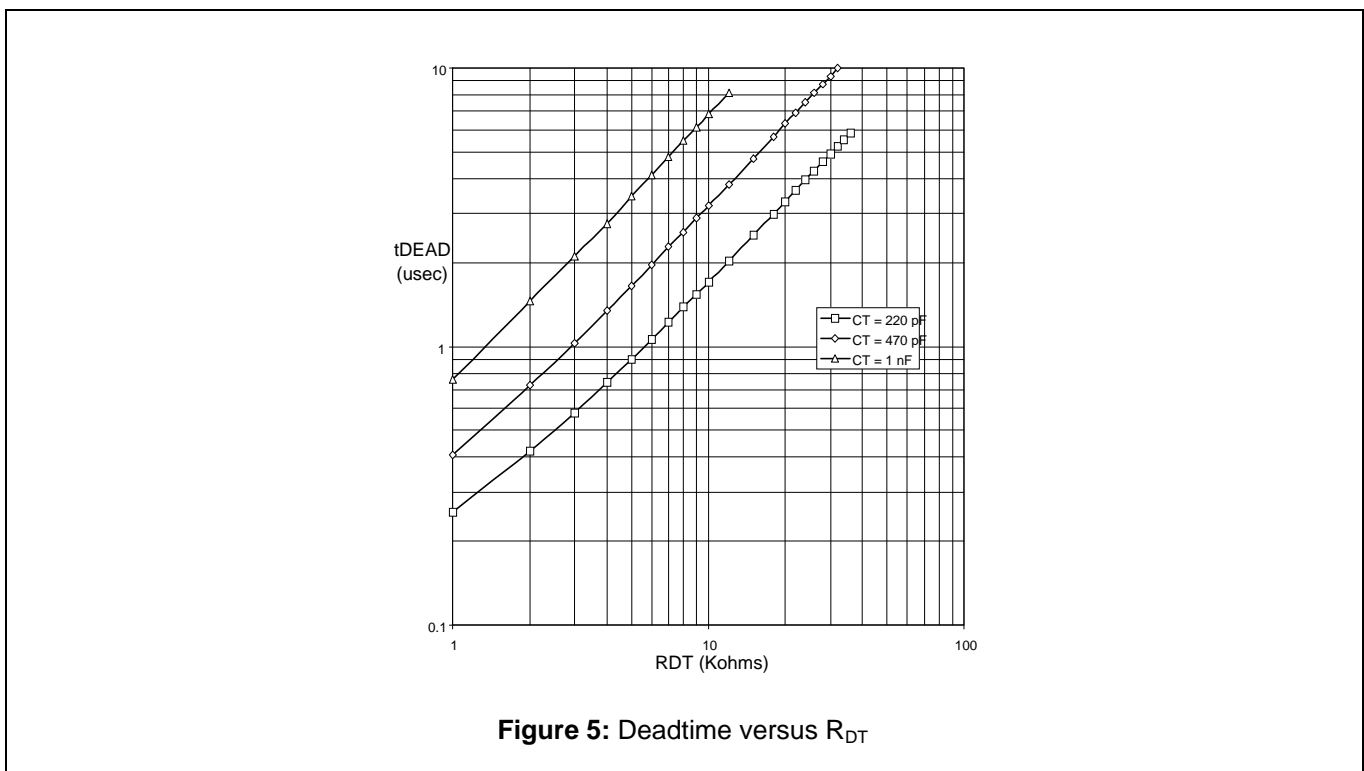

The  $R_T$  input is a voltage-controlled current source, where the voltage is regulated to be approximately 2.0V. In order to maintain proper linearity between the  $R_T$  pin current and the  $C_T$  capacitor charging current, the value of the  $R_T$  pin current should be kept between 50 $\mu$ A and 500 $\mu$ A. The  $R_T$  pin can also be used as a feedback point for closed loop control.

During the **Startup Mode**, the operating frequency is determined by the parallel combination of  $R_{PH}$  and  $R_T$ , combined with the values of  $C_T$  and  $R_{DT}$ , and the voltage at the  $R_T$  pin, as shown in Figure 6. The voltage at the  $R_T$  pin starts at an initial value above 2V, causing the initial start frequency to be higher than the preheat frequency. This frequency is high enough to ensure that the instantaneous voltage across the lamp during the first few cycles of operation does not exceed the strike potential of the lamp. As the voltage at the  $R_T$  pin decreases to the final value of 2V, the output frequency ramps down to the preheat frequency.

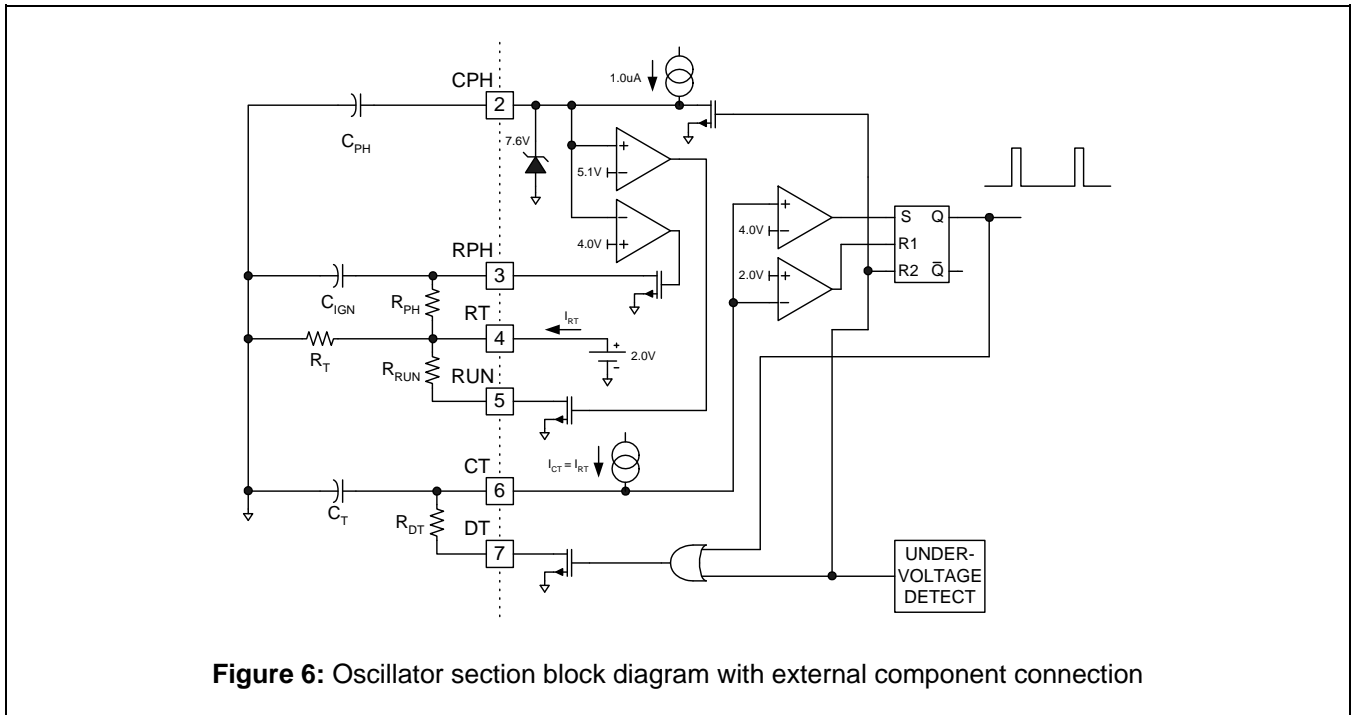

**Figure 6:** Oscillator section block diagram with external component connection

During the **Preheat Mode**, the operating frequency is determined by the parallel combination of  $R_{PH}$  and  $R_T$ , combined with the value of  $C_T$  and  $R_{DT}$ . This frequency, along with the **Preheat Time**, is normally chosen to ensure that adequate heating of the lamp filaments occurs. Typically, a 4.5:1 ratio of the hot filament-to-cold filament resistance is desired for maximum lamp life, as shown in Figure 7 below

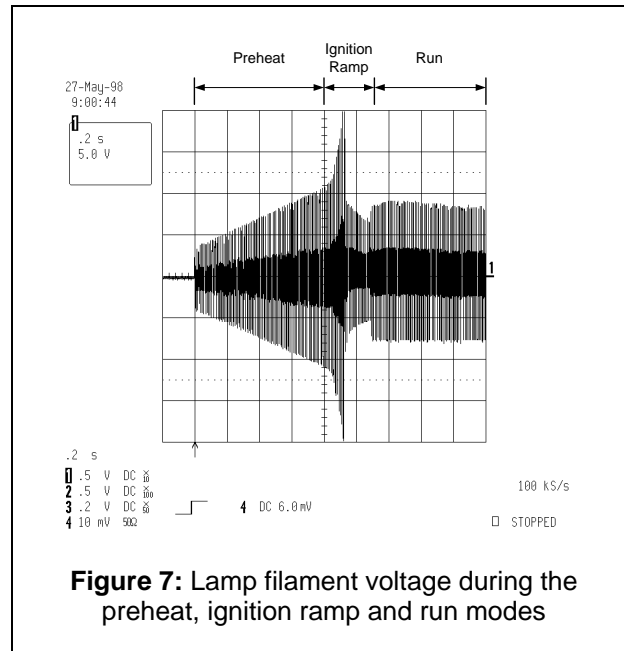

The **Preheat Time** is programmed by means of the preheat capacitor,  $C_{PH}$ , an internal  $1\mu A$  current source, and an internal threshold on the CPH pin of 4.0V, according to the following formula:

$$t_{PH} = 4E6 \cdot C_{PH}, \quad \text{or}$$

$$C_{PH} = 250E-9 \cdot t_{PH}$$

At the end of the **Preheat Time**, the internal, open-drain transistor holding the RPH pin to ground turns off, and the voltage on this pin charges exponentially up to the  $R_T$  pin potential. During this **Ignition Ramp Mode**, the output frequency exponentially decays to a minimum value. The rate of decay of this frequency is a function of the  $R_{PH} * C_{RAMP}$  time constant. Because the **Ignition Ramp Mode** ends when the voltage on the CPH pin reaches 5.15V, the **Ignition Ramp Mode** is always 1/4th as long as the preheat time.

When the CPH pin reaches 5.15V, an open-drain transistor on the RUN pin turns on, and the external  $R_{RUN}$  resistor is then in parallel with the  $R_T$  resistor. The **Run Mode** operating frequency is therefore a function of the parallel combination of  $R_{RUN}$  and  $R_T$ , and this means that the operating power of the lamp can be programmed by means of  $R_{RUN}$ .

The following graphs, Figures 8 and 9, illustrate the relationship between the effective  $R_T$  resistance (i.e., the parallel combination of resistors which programs the  $C_T$  capacitor charging current) and the operating frequency.

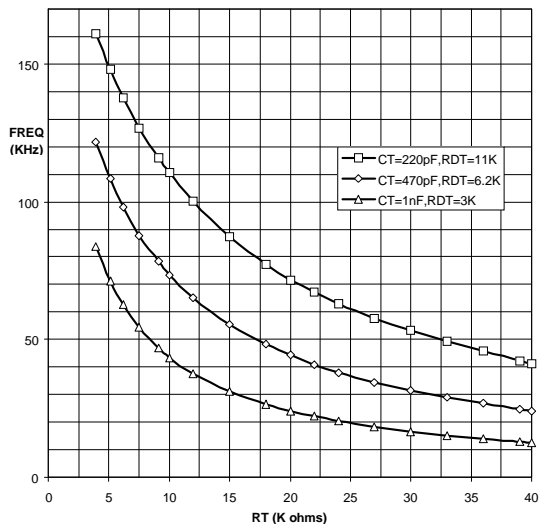

**Figure 8:**  $f_{OSC}$  versus effective  $R_T$   
( $t_{DEAD} = 2.0 \mu\text{sec}$ )

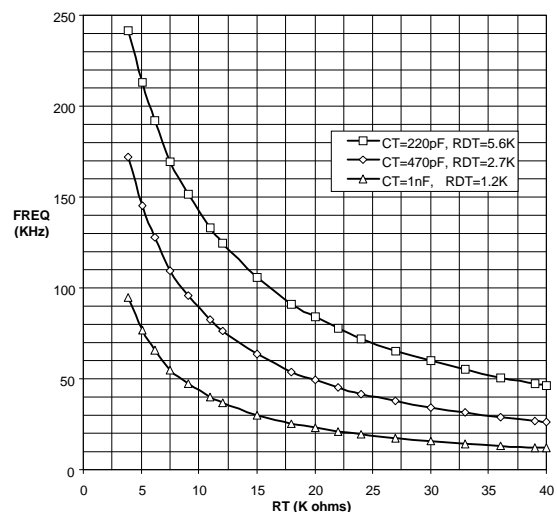

**Figure 9:**  $f_{OSC}$  versus effective  $R_T$   
( $t_{DEAD} = 1.0 \mu\text{sec}$ )

## Lamp Protection & Automatic Restart Circuitry Operation

Four pins on the IRS21571D are used for protection, as shown in Figure 10 below. These are VDC (dc bus monitor), SD (unlatched shutdown), CS (latched shutdown) and OC (CS+ threshold programming).

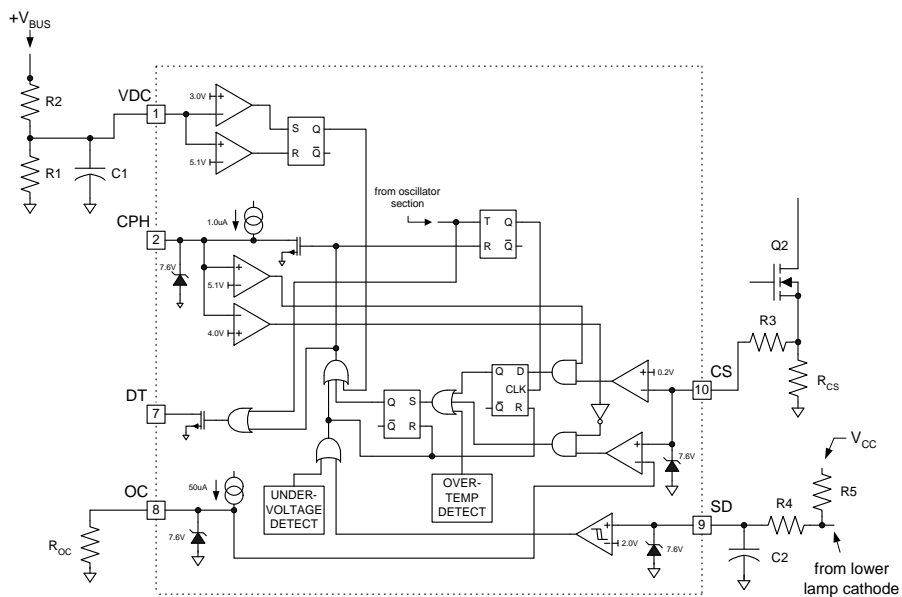
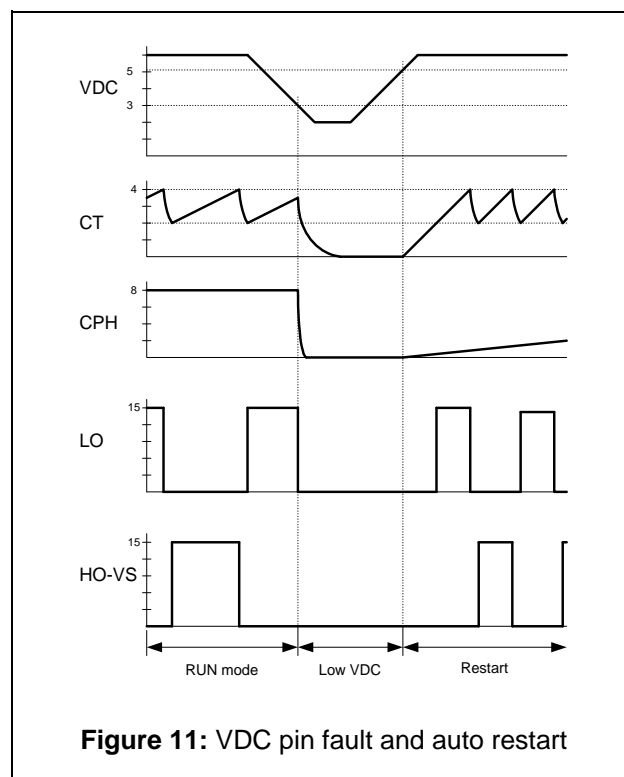

**Figure 10:** Lamp Protection & Automatic Restart circuitry block diagram with external component connection

## Sensing The DC Bus Voltage

The first of these protection pins senses the voltage on the DC bus by means of an external resistor divider and an internal comparator with hysteresis.

When power is first supplied to the IC at system startup, 3 conditions are required before oscillation is initiated: 1.) the voltage on the VCC pin must exceed the rising undervoltage lockout threshold (12.5V), 2.) the voltage at the VDC pin must exceed 5.1V, and 3.) the voltage on the SD pin must be below approximately 1.85V. If a low dc bus condition occurs during normal operation, or if power to the ballast is shut off, the dc bus will collapse prior to the VCC of the chip (assuming the VCC is derived from a charge pump off of the output of the half-bridge). In this case, the voltage on the VDC pin will shut the oscillator off, thereby protecting the power transistors from potentially hazardous hard switching. Approximately 2V of hysteresis has been designed into the internal comparator sensing the VDC pin, in order to account for variations in the dc bus voltage under varying load conditions. When the dc bus recovers, the chip restarts from the beginning of the control sequence, as shown in timing diagram Figure 11 below.



## Lamp Presence Detection and Automatic Restart

The second protection pin, SD, is used for both unlatched shutdown and automatic restart functions. The SD pin would normally be connected to an external circuit which senses the presence of the lamp (or lamps). A example circuit for a single lamp is shown in Figure 12.

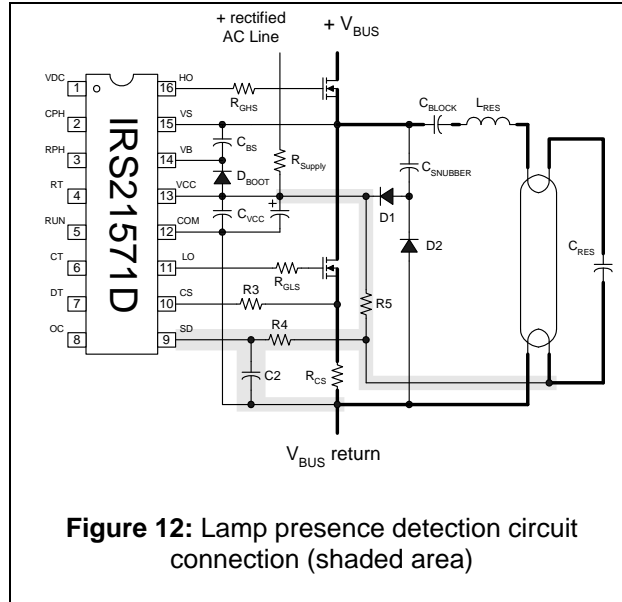

When the SD pin exceeds 2.0V (approximately 150mV of hysteresis is included to increase noise immunity), signaling either a lamp fault or lamp removal, the oscillator is disabled, both gate driver outputs are pulled low, and the chip is put into the micropower mode. Since a lamp fault would normally lead to a lamp exchange, when a new lamp is inserted into the fixture, the SD pin would be pulled back to near the ground potential. Under these conditions a reset signal would restart the chip from the beginning of the control sequence, as shown in the timing diagram in Figure 13.

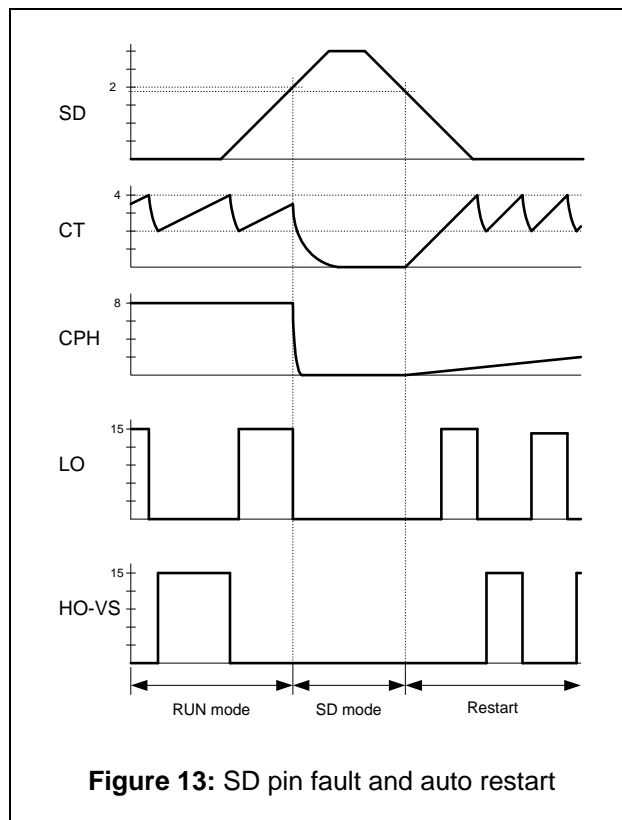

Thus, for a lamp removal and replacement, the ballast automatically restarts the lamp in the proper manner, maximizing lamp life and minimizing stress on the power MOSFETs or IGBTs.

## Half-Bridge Current Sensing and Protection

The third pin used for protection is the CS pin, which is normally connected to a resistor in the source of the lower power MOSFET, as shown in Figure 14.

The CS pin is used to sense fault conditions such as failure of a lamp to strike, over-current during normal operation, hard switching, no load, and operation below resonance. If any one of these conditions is sensed, the fault latch is set, the oscillator is disabled, the gate driver outputs go low, and the chip is put into the micropower mode. The CS pin performs its sensing functions on a cycle-by-cycle basis in order to maximize ballast reliability.

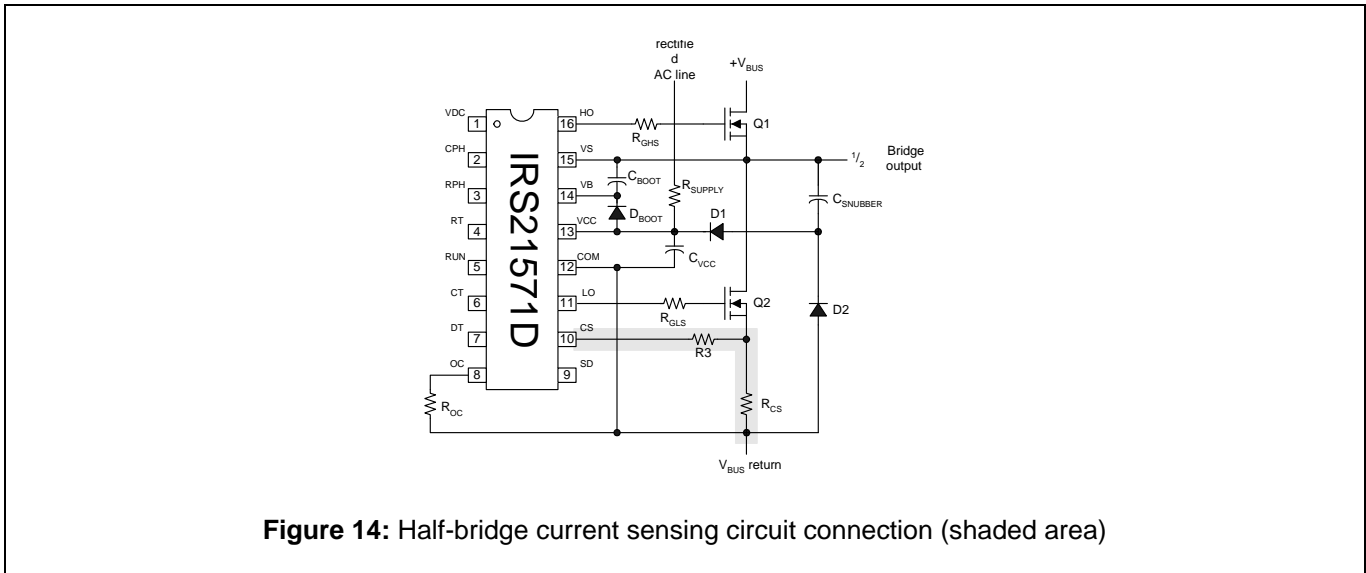

For the over-current, failure-to-strike, and hard switching fault conditions, an externally programmable, positive-going CS+ threshold is enabled at the end of the preheat time. The level of this positive-going threshold is determined by the value of the resistor ROC. The value of the resistor ROC is determined by the following formula:

$$R_{OC} = \frac{V_{CS+}}{50E-6}, \quad \text{or}$$

$$V_{CS+} = 50E-6 \cdot R_{OC}$$

For the under-current and under-resonance conditions, there is a negative-going CS- threshold of 0.2V which is enabled at the onset of the run mode. The sensing of this CS- threshold is synchronized with the falling edge of the LO output.

Figures 15, 16 and 17 are oscillographs of fault conditions. Figure 15 shows a failure of the lamp to strike, Figure 16 shows a hard switching condition and Figure 17 shows an under-current condition.

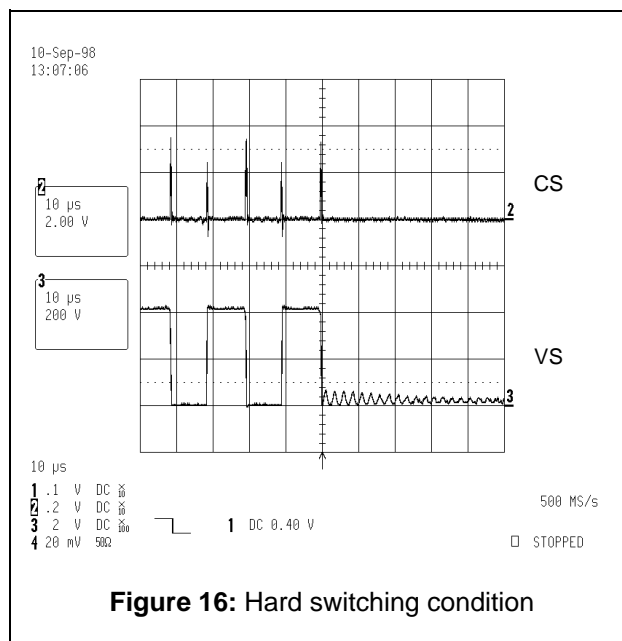
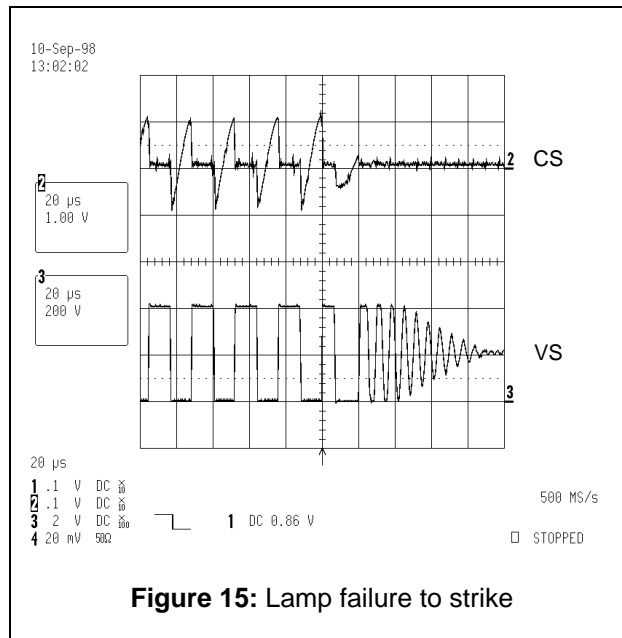

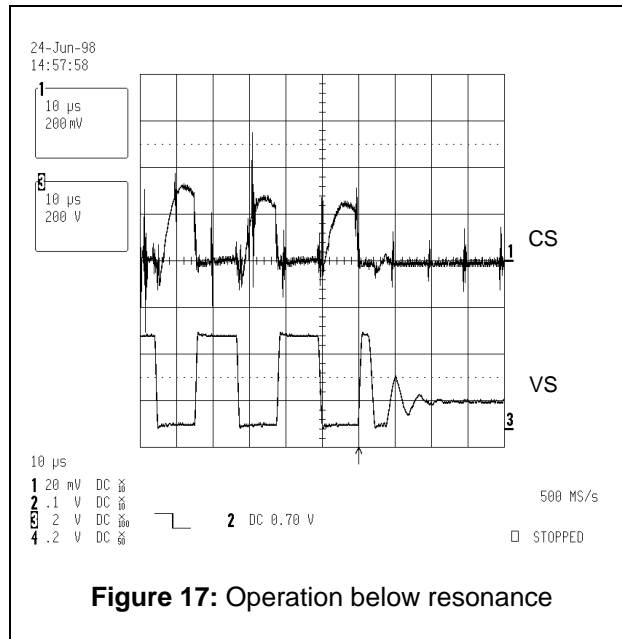

Recovery from such a fault condition is accomplished by cycling either SD pin or the VCC pin. When a lamp is removed, the SD pin goes high, the fault latch is reset, and the chip is held off in an unlatched state. Lamp replacement causes the SD pin to go low again, reinitiating the startup sequence. The fault latch can also be reset by the undervoltage lockout signal, if VCC falls below the lower undervoltage threshold.

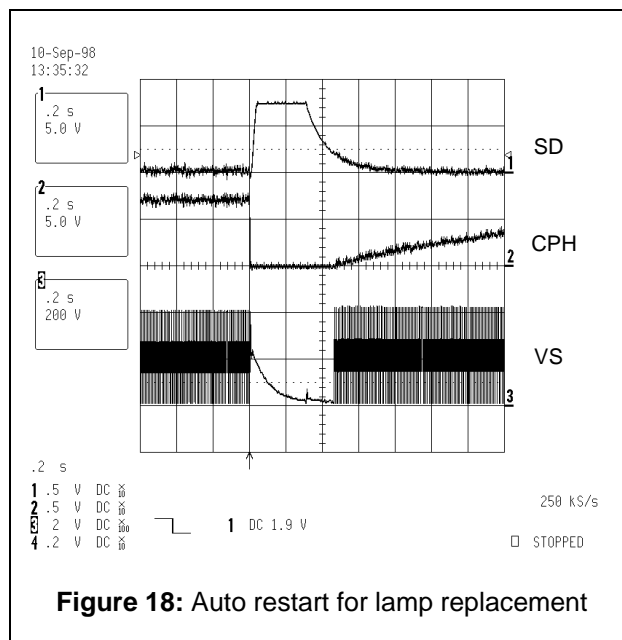

## Package Details: SO16N

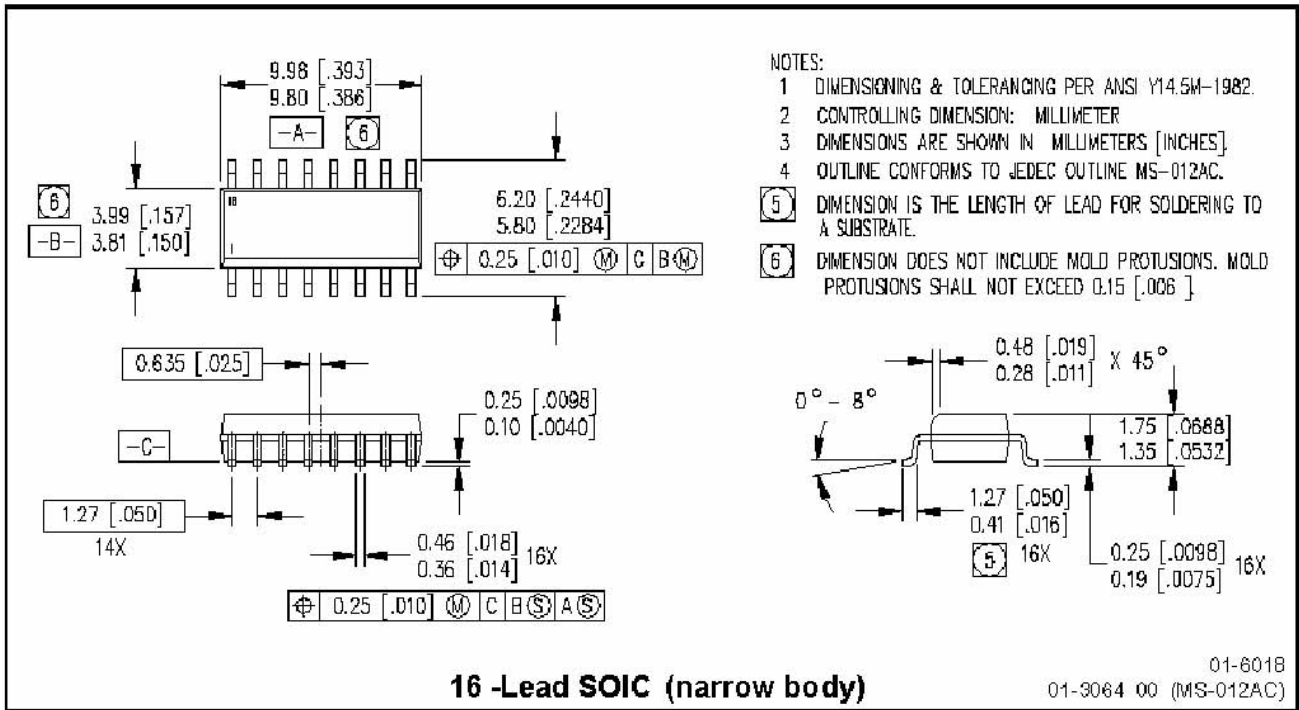

## Package Details: SOIC16N, Tape and Reel

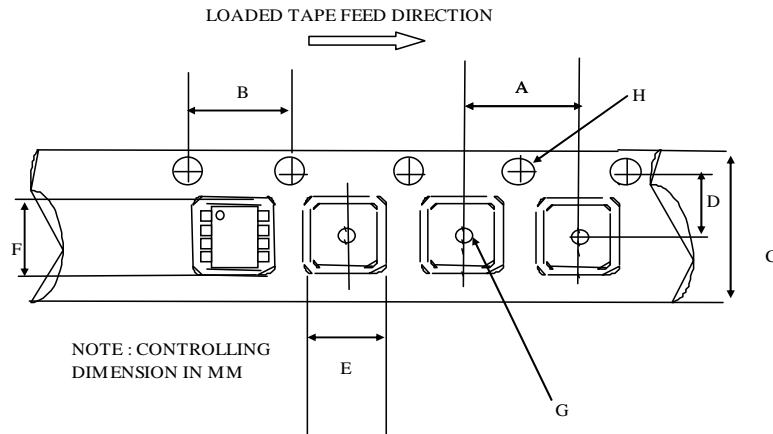

CARRIER TAPE DIMENSION FOR 16SOICN

Code	Metric		Imperial	
	Min	Max	Min	Max
A	7.90	8.10	0.311	0.318
B	3.90	4.10	0.153	0.161
C	15.70	16.30	0.618	0.641
D	7.40	7.60	0.291	0.299
E	6.40	6.60	0.252	0.260
F	10.20	10.40	0.402	0.409
G	1.50	n/a	0.059	n/a
H	1.50	1.60	0.059	0.062

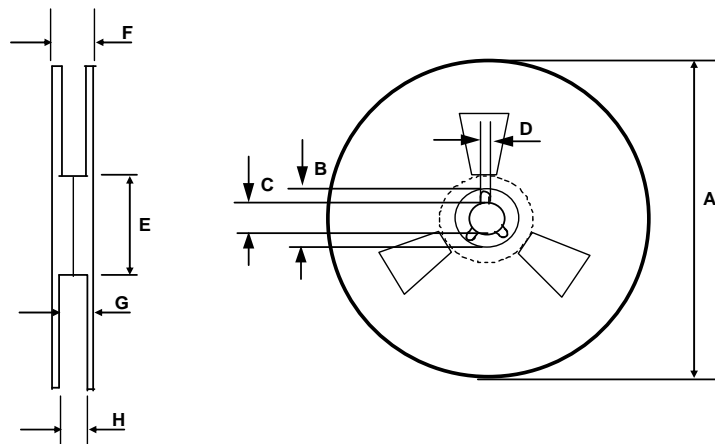

REEL DIMENSIONS FOR 16SOICN

Code	Metric		Imperial	
	Min	Max	Min	Max
A	329.60	330.25	12.976	13.001
B	20.95	21.45	0.824	0.844
C	12.80	13.20	0.503	0.519
D	1.95	2.45	0.767	0.096
E	98.00	102.00	3.858	4.015
F	n/a	22.40	n/a	0.881
G	18.50	21.10	0.728	0.830
H	16.40	18.40	0.645	0.724



Part Marking Information

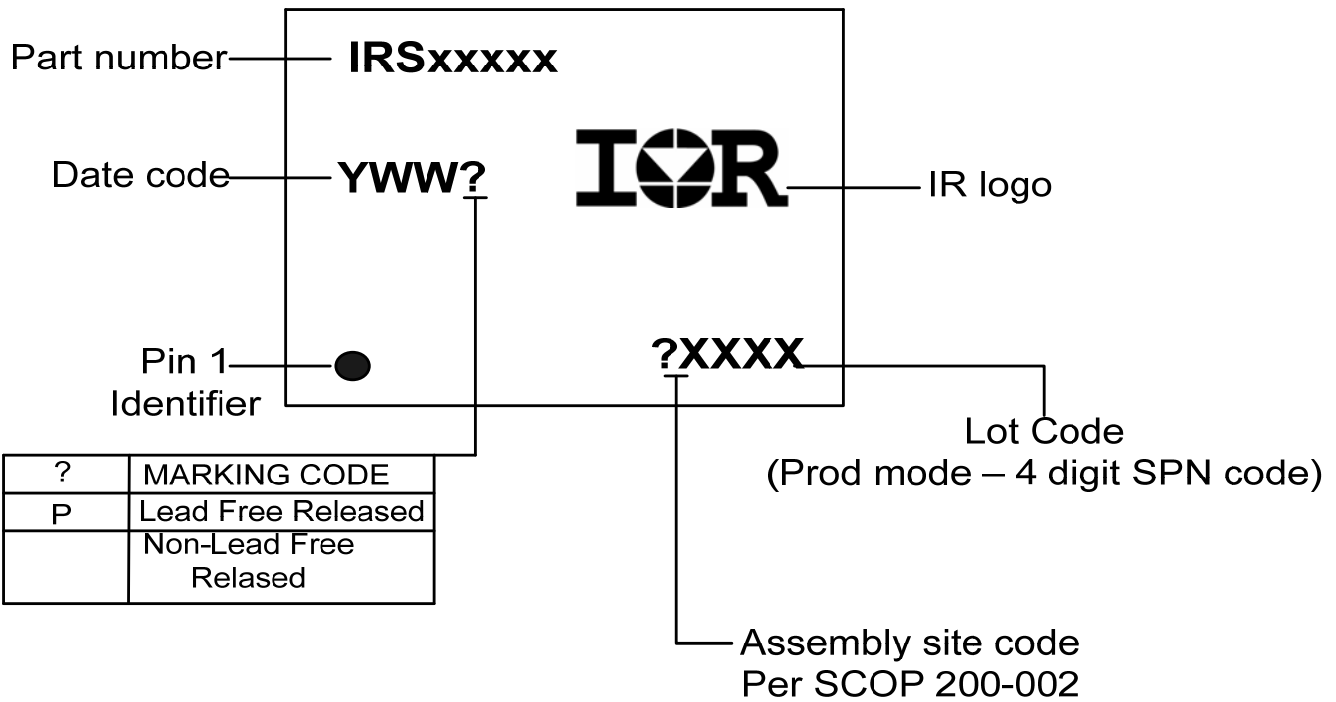



Ordering Information

Base Part Number	Package Type	Standard Pack		Complete Part Number
		Form	Quantity	
IRS21571D	SOIC16N	Tube/Bulk	48	IRS21571DSPBF
	SOIC16N	Tape and Reel	2500	IRS21571DSTRPBF

The information provided in this document is believed to be accurate and reliable. However, International Rectifier assumes no responsibility for the consequences of the use of this information. International Rectifier assumes no responsibility for any infringement of patents or of other rights of third parties which may result from the use of this information. No license is granted by implication or otherwise under any patent or patent rights of International Rectifier. The specifications mentioned in this document are subject to change without notice. This document supersedes and replaces all information previously supplied.

For technical support, please contact IR's Technical Assistance Center  
<http://www.irf.com/technical-info/>

**WORLD HEADQUARTERS:**  
233 Kansas St., El Segundo, California 90245  
Tel: (310) 252-7105