

Version	Date	Author	Change Note	Note
V00	20150130	HWQ	The first edit	
V01	20150312	HWQ	Increase pull-up resistor for adcin1.	
V10	20150611	HWQ	L5 and L6's package was changed.	

		www.t-firefly.com	
Title: Change List			
File: FirePrime			REV: V10
Create Date: Monday, June 01, 2015		Page Num: 2	
Modify Date: Monday, June 15, 2015		Page Total: 16	

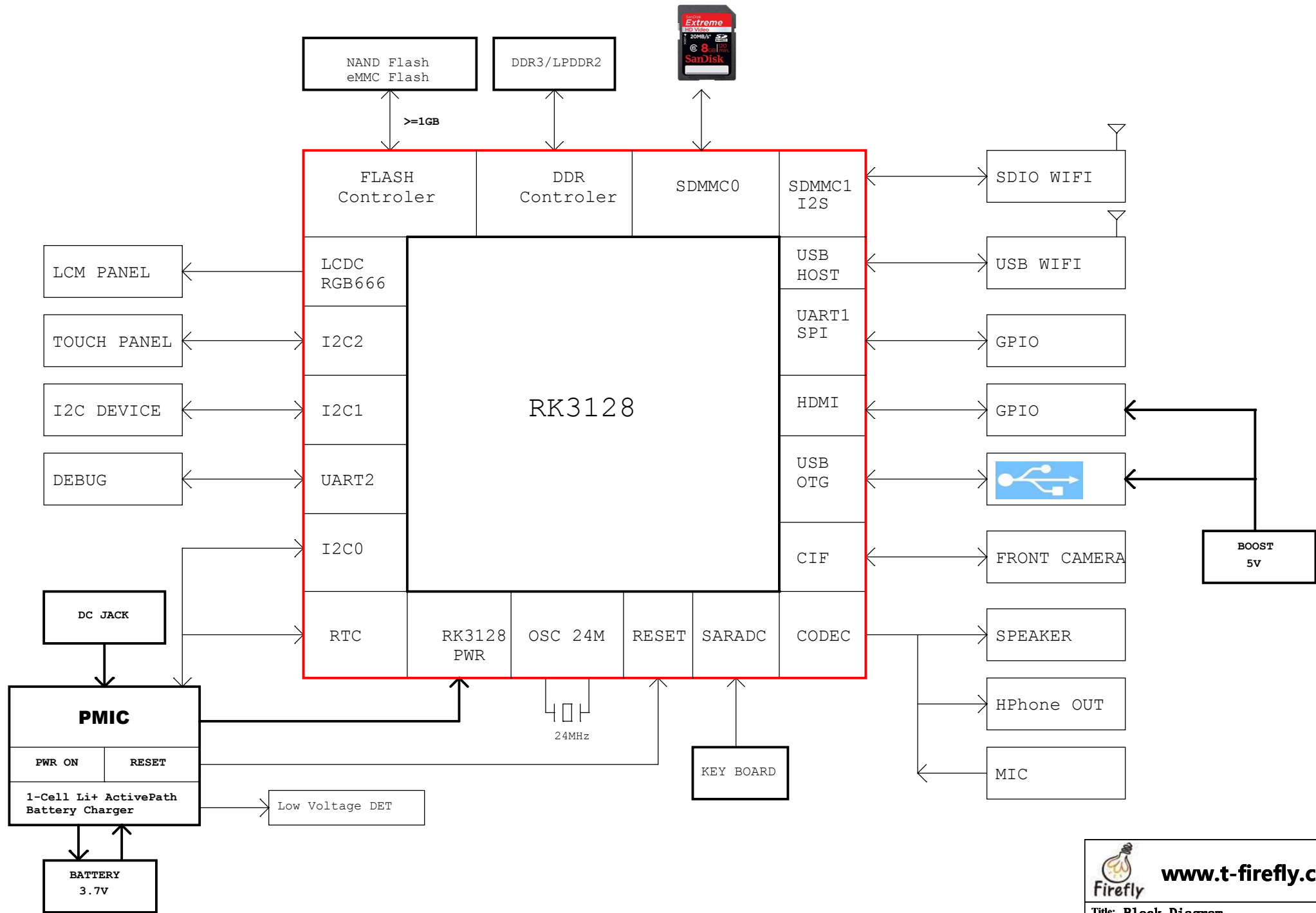

POWER DIAGRAM

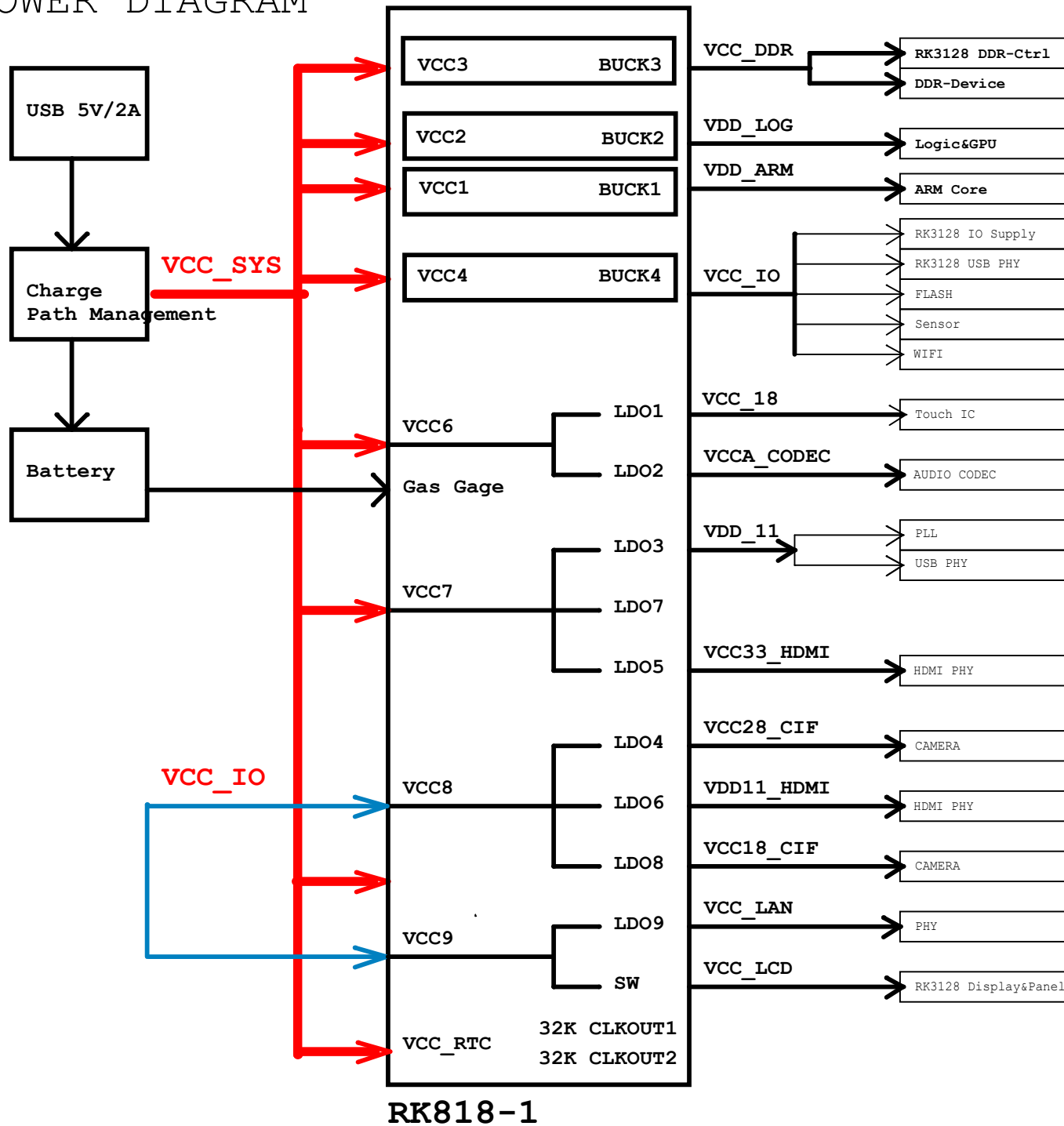

PowerName	PMU Channel	TIMER (2mS)	default ON/OFF	default voltage	sleep ON/OFF
VDD_ARM	DCDC1	solt:3	ON	1.1V	ON
VDD_LOG	DCDC2	solt:1	ON	1.1V	ON
VCC_DDR	DCDC3	solt:4	ON	DDR3 1.5V DDR3L 1.35V LPDDR 1.2V	ON
VCC_IO	DCDC4	solt:1	ON	3.0V	ON
VCC_18	VLD01	X	OFF	3.3V	OFF
VCCA_CODEC	VLD02	X	OFF	3.0V	OFF
VDD_11	VLD03	solt:1	ON	1.1V	ON
VCC28_CIF	VLD04	solt:2	ON	2.5V	OFF
VCC33_HDMI	VLD05	solt:1	ON	3.0V	ON
VDD11_HDMI	VLD06	X	OFF	1.2V	OFF
VCCi8_CIF	VLD07	solt:2	ON	1.8V	OFF
VCC_LAN	VLD08	X	OFF	1.8V	OFF
VCC_LCD	VLD09	solt:4	ON	3.0V	OFF
VCC_LCD	VSWOUT1	X	OFF	X	OFF



www.t-firefly.com

Title: Power Tree-RK818	
File: FirePrime	REV: V10
Create Date: Monday, June 01, 2015	Page Num: 4
Modify Date: Wednesday, June 10, 2015	Page Total: 16

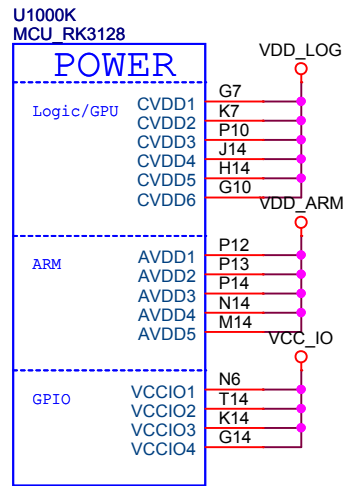

RK3128-K

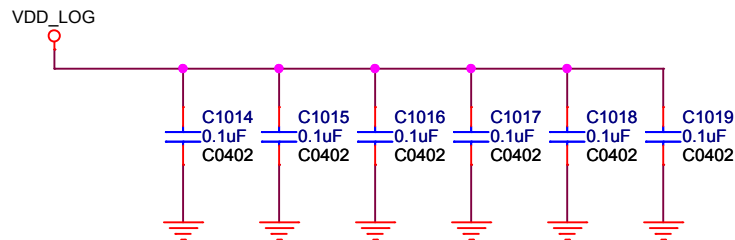
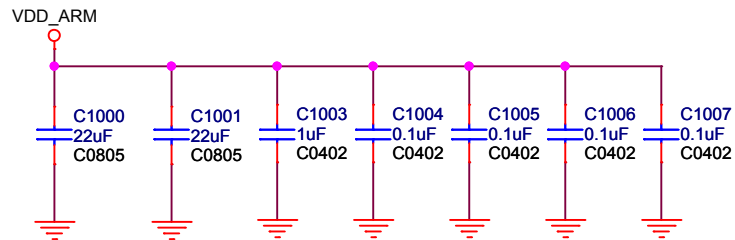

Note:
Place these filter capacitors under CPU.

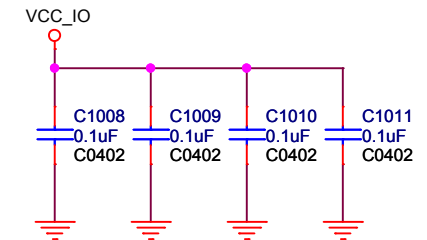
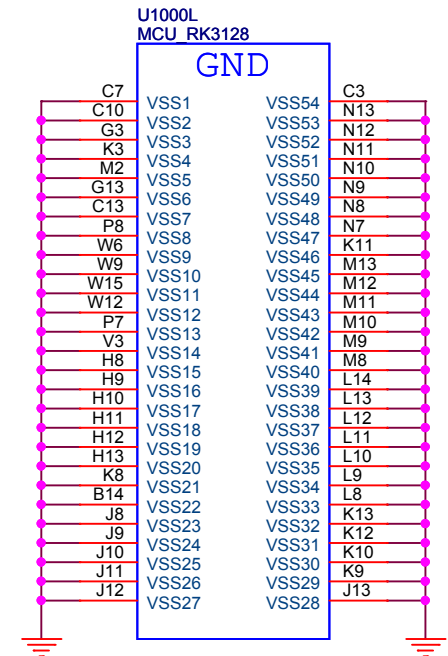

RK3128-L

www.t-firefly.com

Title: RK3128 Power

File: FirePrime REV: V10

Create Date: Monday, June 01, 2015 Page Num: 5

Modify Date: Wednesday, June 10, 2015 Page Total: 16

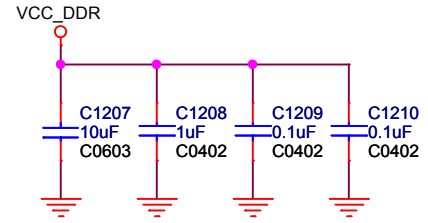
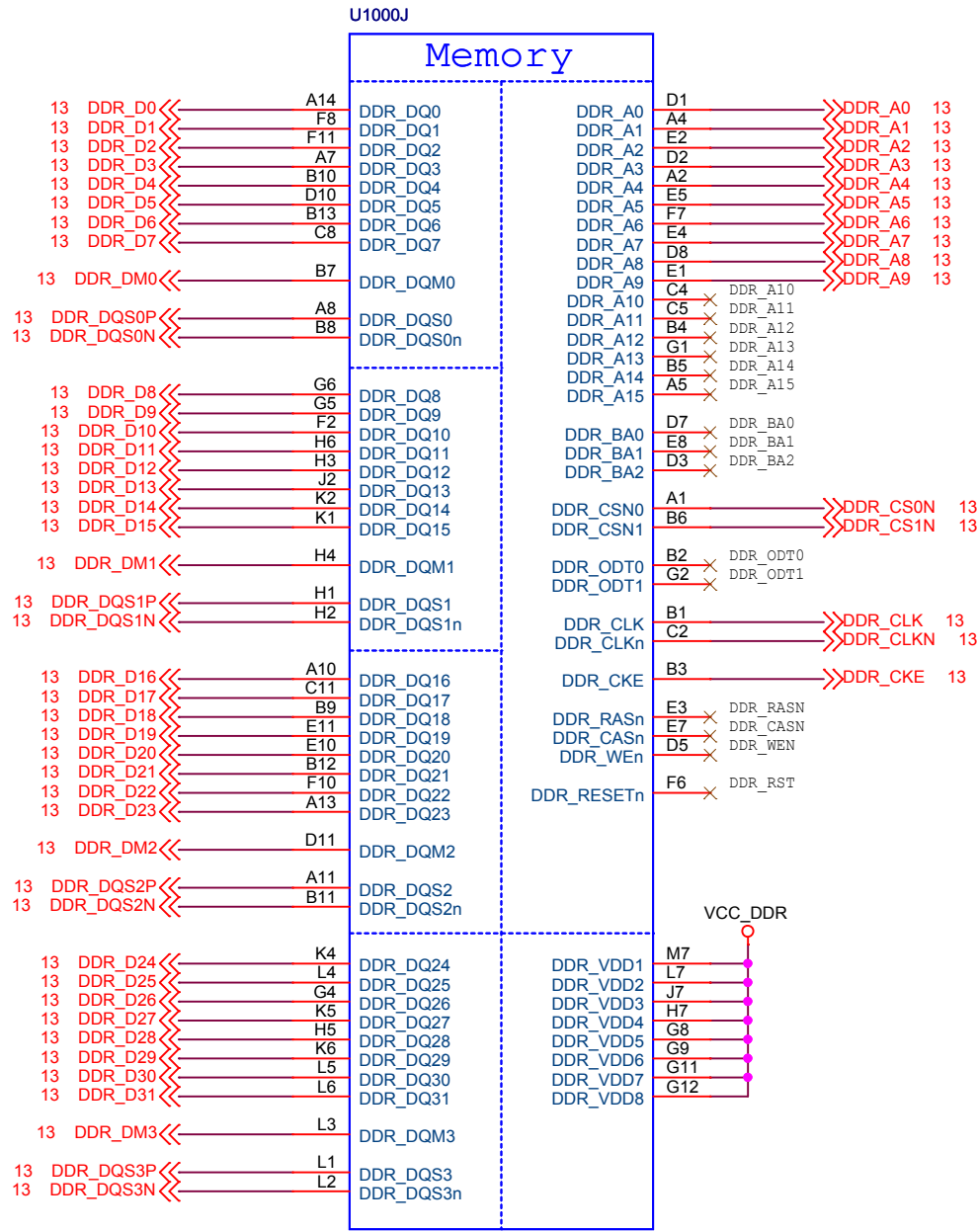



www.t-firefly.com

Title: RK3128 DDR Controller

File: FirePrime		REV: V10
Create Date: Monday, June 01, 2015	Page Num: 6	
Modify Date: Wednesday, June 10, 2015	Page Total: 16	

RK3128-E

U1000E
MCU_RK3128

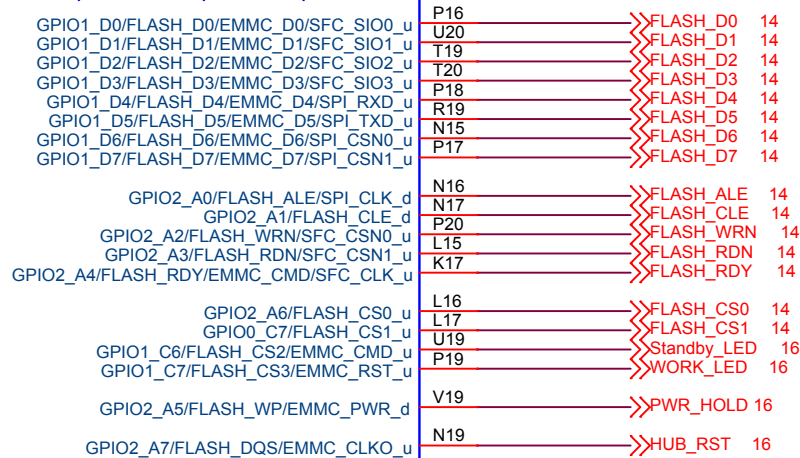

Nand Flash/eMMC/SFC/SPI



RK3128-D

U1000D
MCU_RK3128

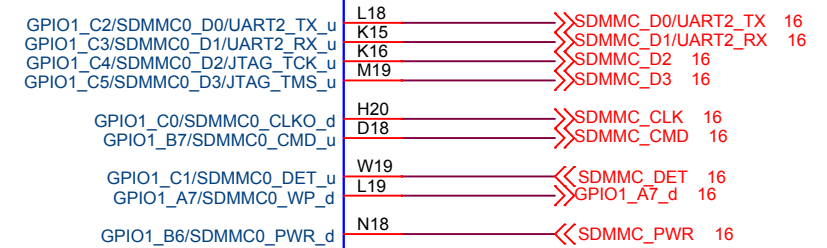
SDMMC0

www.t-firefly.com

Title: RK3128 Flash/SD Controller

File: FirePrime REV: V10

Create Date: Monday, June 01, 2015	Page Num: 7
Modify Date: Wednesday, June 10, 2015	Page Total: 16

RK3128-C

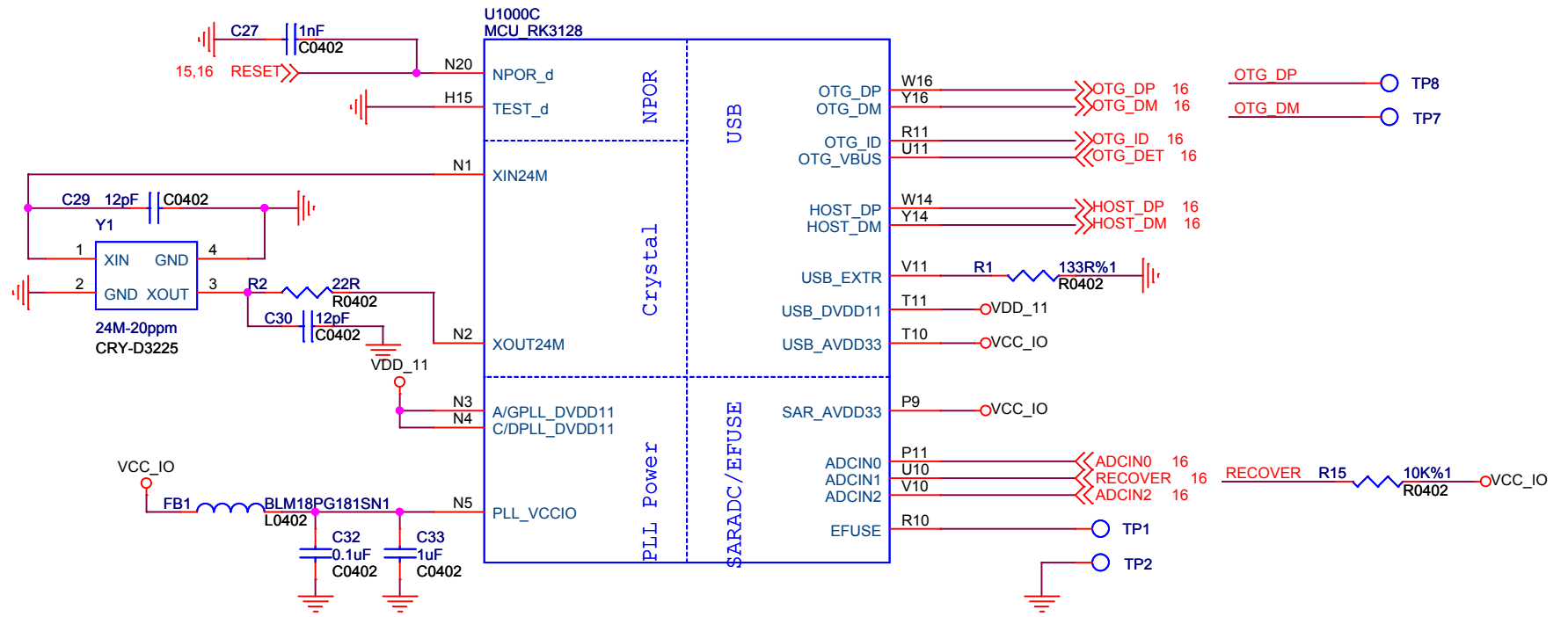

Note: All the capacitor should be place close to the power pin of RK3128.

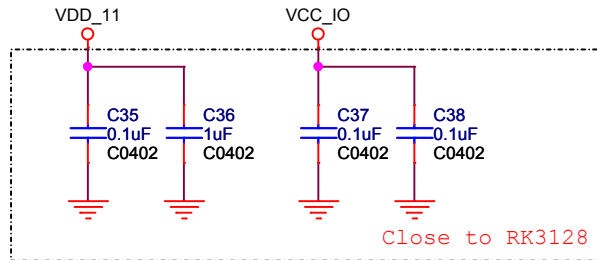



www.t-firefly.com

Title: RK3128 MISC&USB	
File: FirePrime	REV: V10
Create Date: Monday, June 01, 2015	Page Num: 8
Modify Date: Wednesday, June 10, 2015	Page Total: 16

U1000A
MCU RK3128

LCDC/LVDS/MIPI/GMAC/EMAC

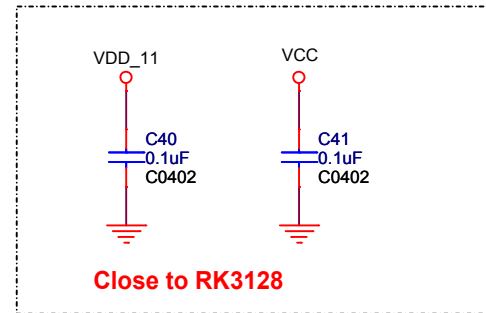
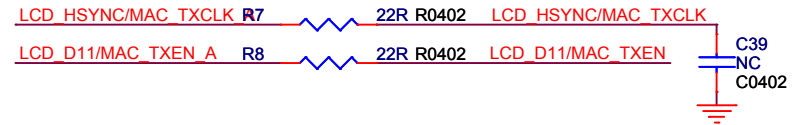
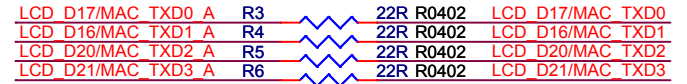
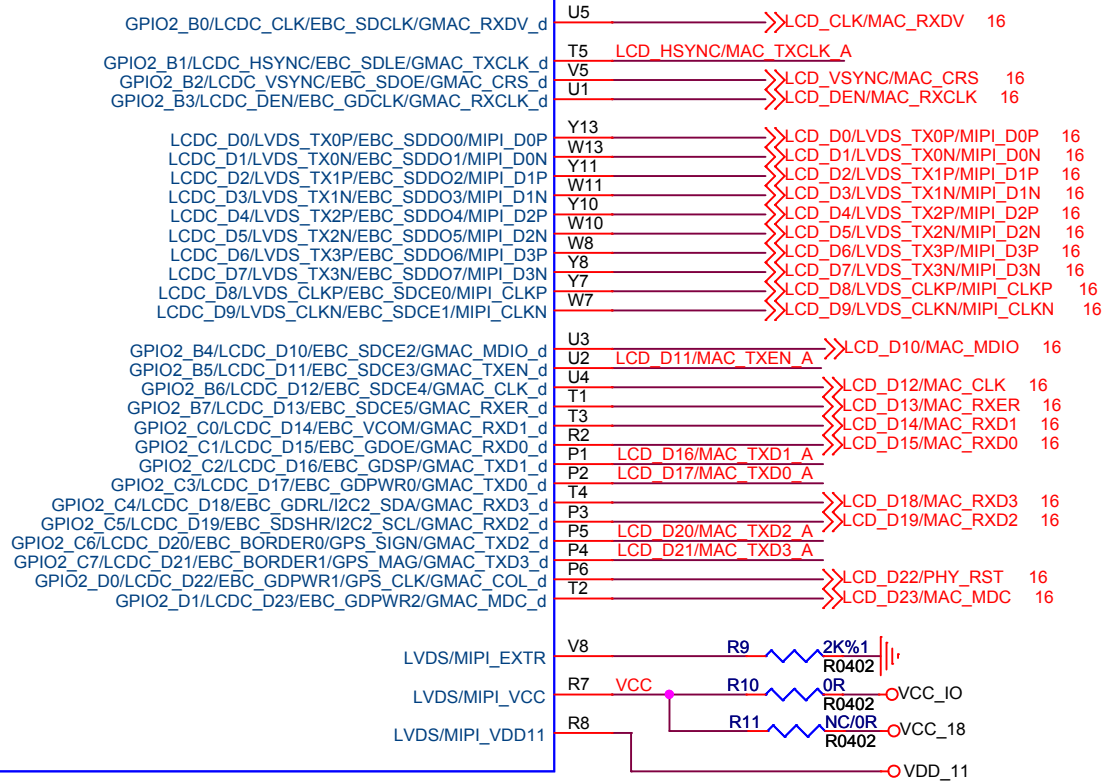

www.t-firefly.com

Title: **RK3128DISPLAY/GMAC Controller**

File: **FirePrime** REV: V10

Create Date: **Monday, June 01, 2015** Page Num: **9**

Modify Date: **Wednesday, June 10, 2015** Page Total: **16**

RK3128-B

U1000B
MCU_RK3128

CIF/TS

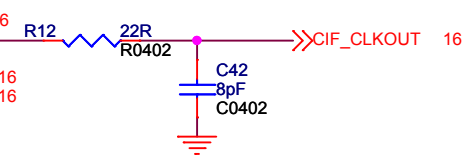
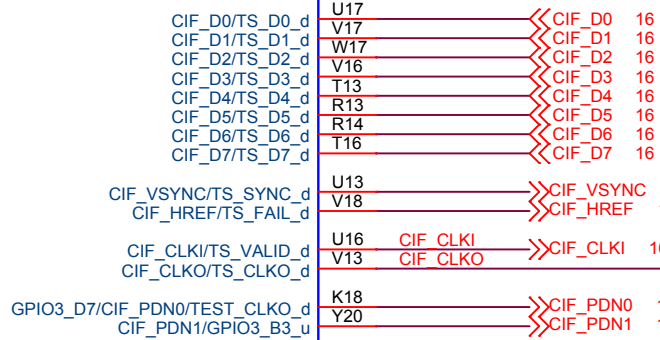

RK3128-H

U1000H

HDMI TX

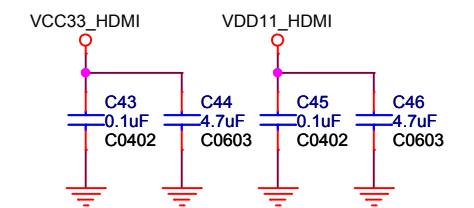
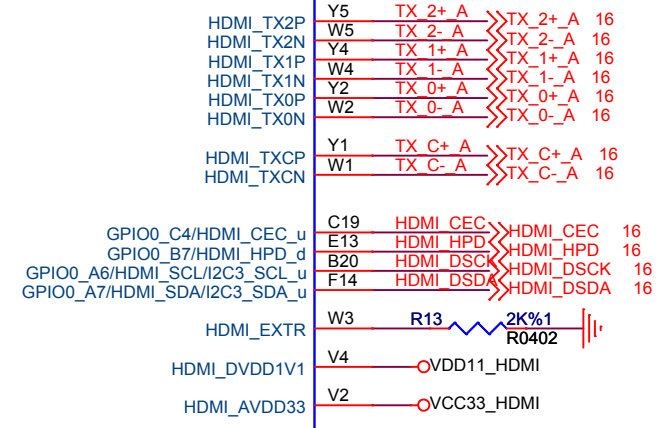

MCU_RK3128



www.t-firefly.com

Title: RK3128 CAMERA/HDMI Controller

File: FirePrime REV: V10

Create Date: Monday, June 01, 2015 Page Num: 10

Modify Date: Wednesday, June 10, 2015 Page Total: 16

RK3128-F

U1000F
MCU_RK3128

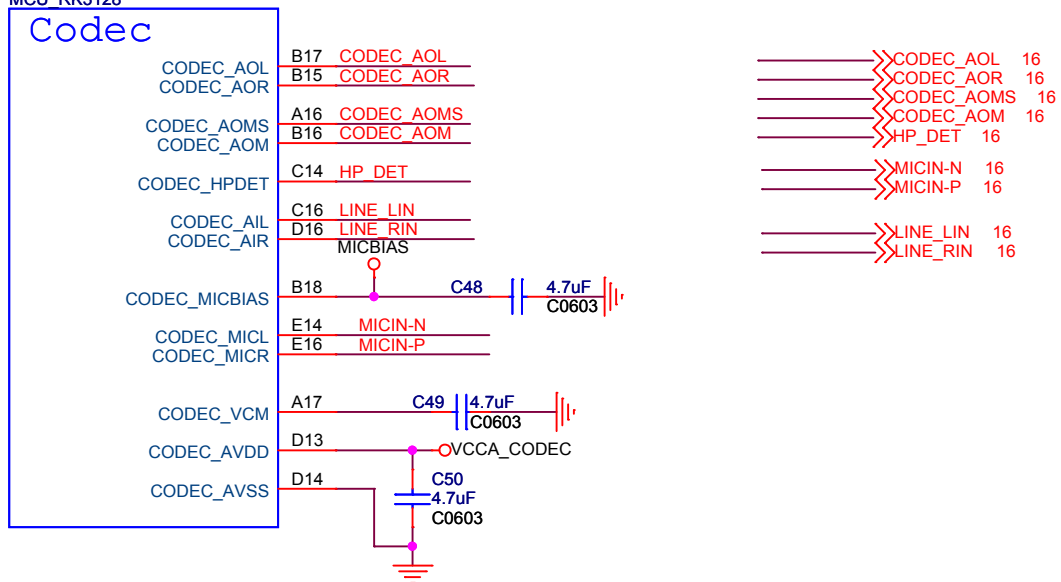

RK3128-G

U1000G

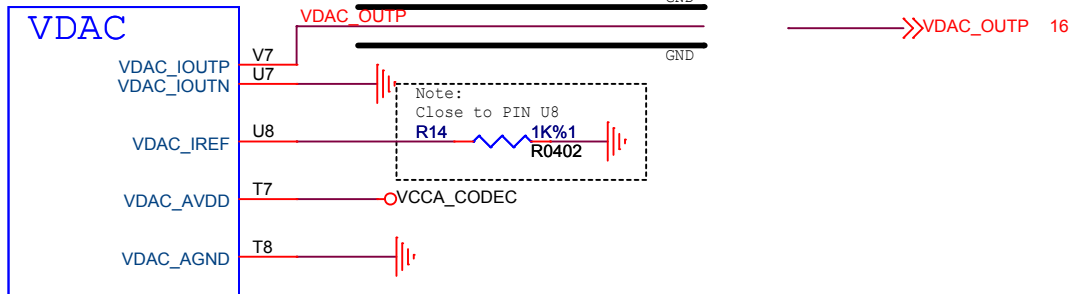

MCU_RK3128

VCCA_CODEC

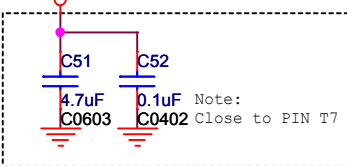

Title: RK3128 CODEC/VDAC	
File: FirePrime	REV: V10
Create Date: Monday, June 01, 2015	Page Num: 11
Modify Date: Wednesday, June 10, 2015	Page Total: 16

U10001
MCU_RK3128

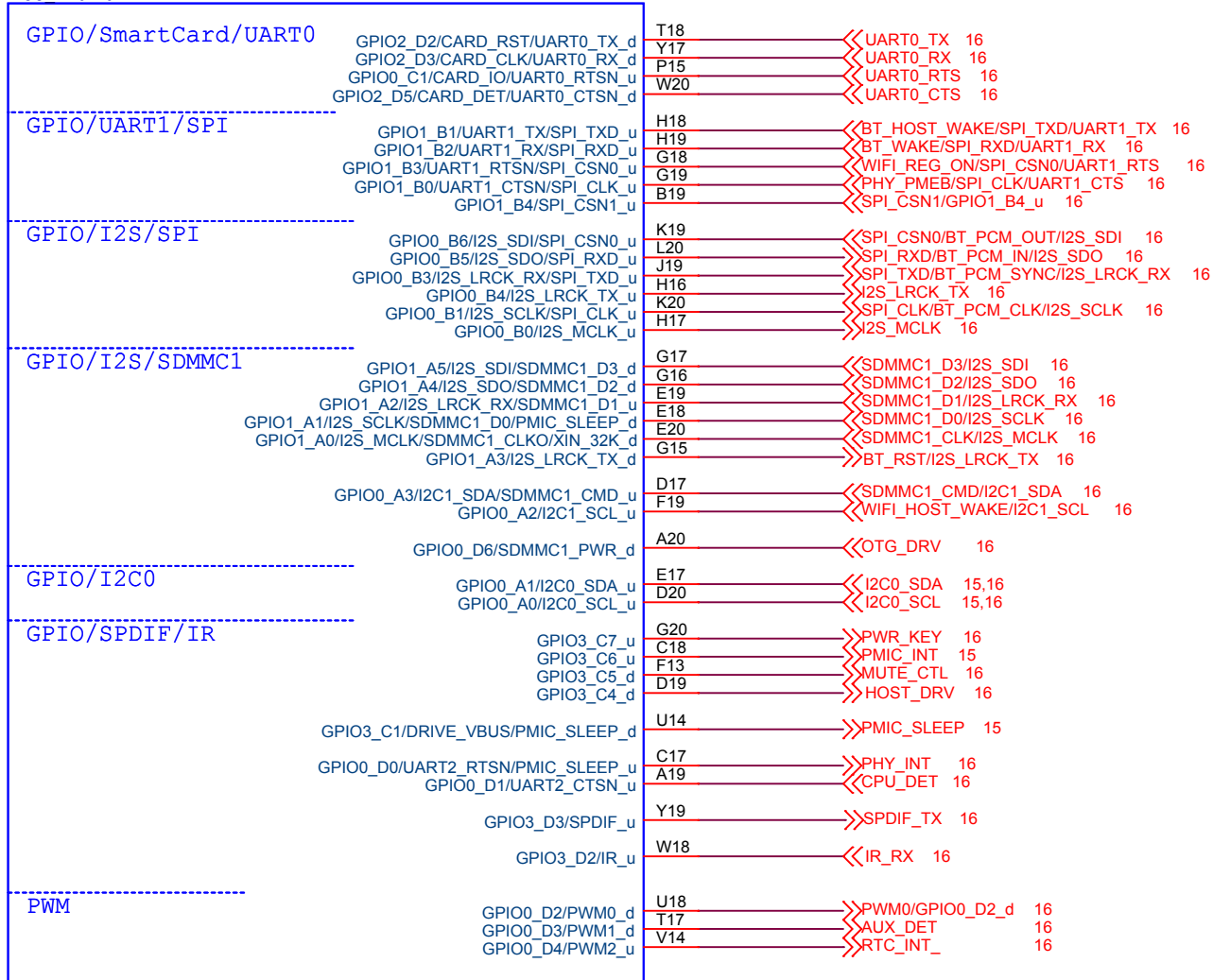



www.t-firefly.com

Title: RK3128 GPIO	
File: FirePrime	REV: V10
Create Date: Monday, June 01, 2015	Page Num: 12
Modify Date: Wednesday, June 10, 2015	Page Total: 16

LPDDR2

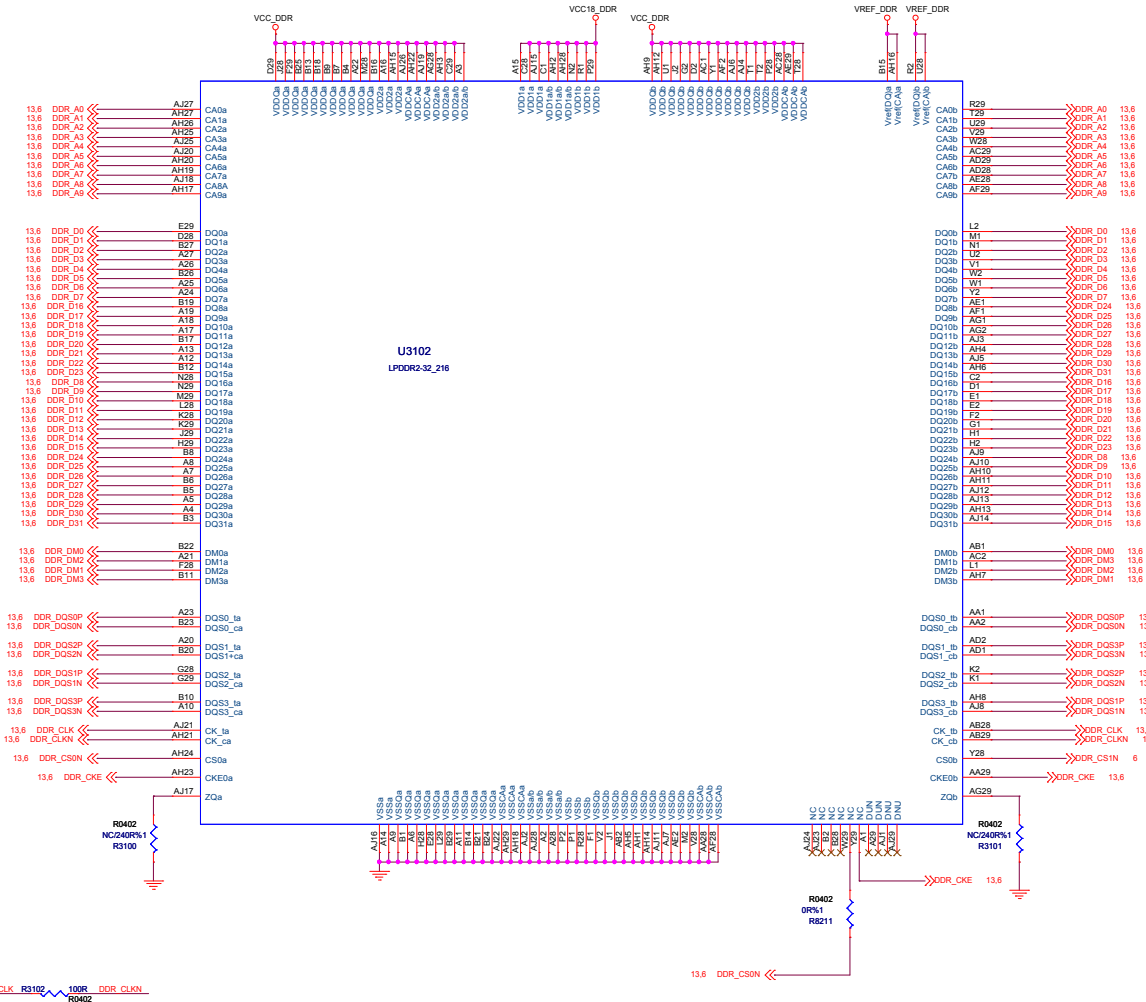

LPDDR2 Power Filter

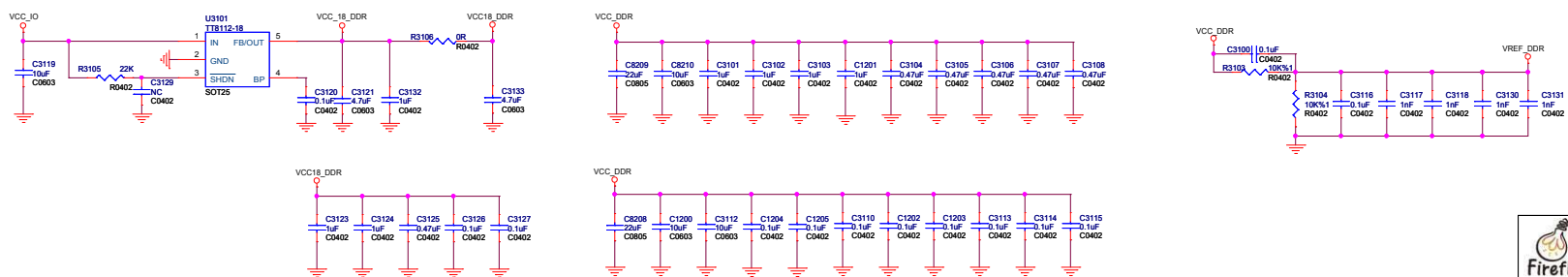

 **www.t-firefly.com**

Title: RAM-LPDDR2

File: FirePrimo

REV: V10

Client Date: Monday, June 01, 2015

Page Num: 13

Modify Date: Wednesday, June 10, 2015

Page Total: 16

NAND FLASH

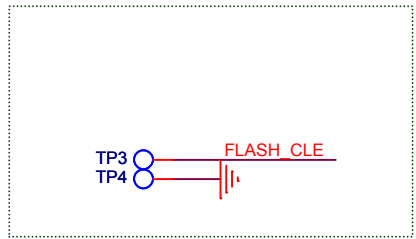
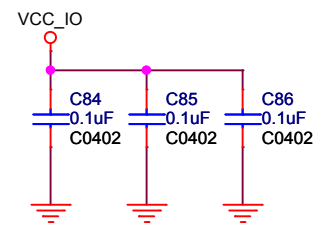
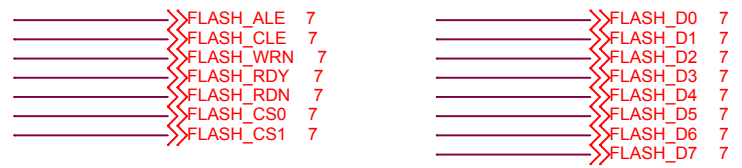
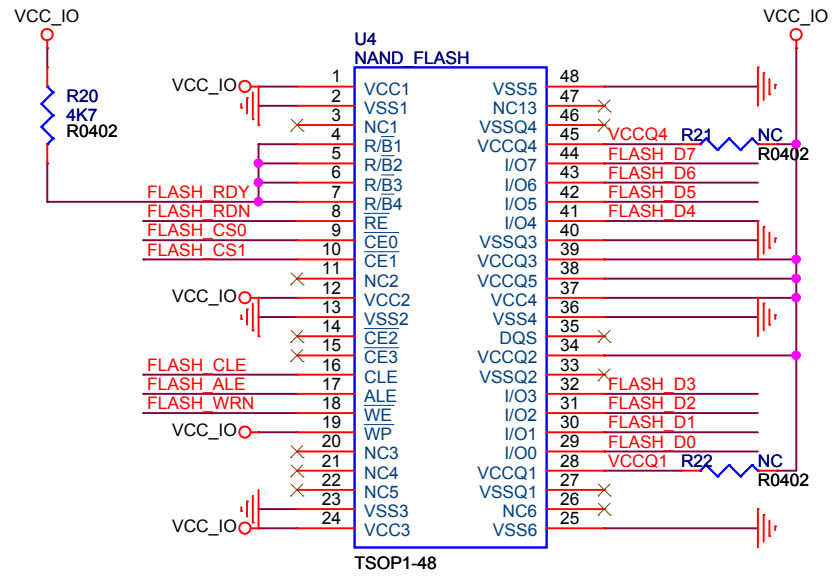



www.t-firefly.com

Title: Memory-Nand Flash

File: FirePrime REV: V10

Create Date: Monday, June 01, 2015 Page Num: 14

Modify Date: Wednesday, June 10, 2015 Page Total: 16

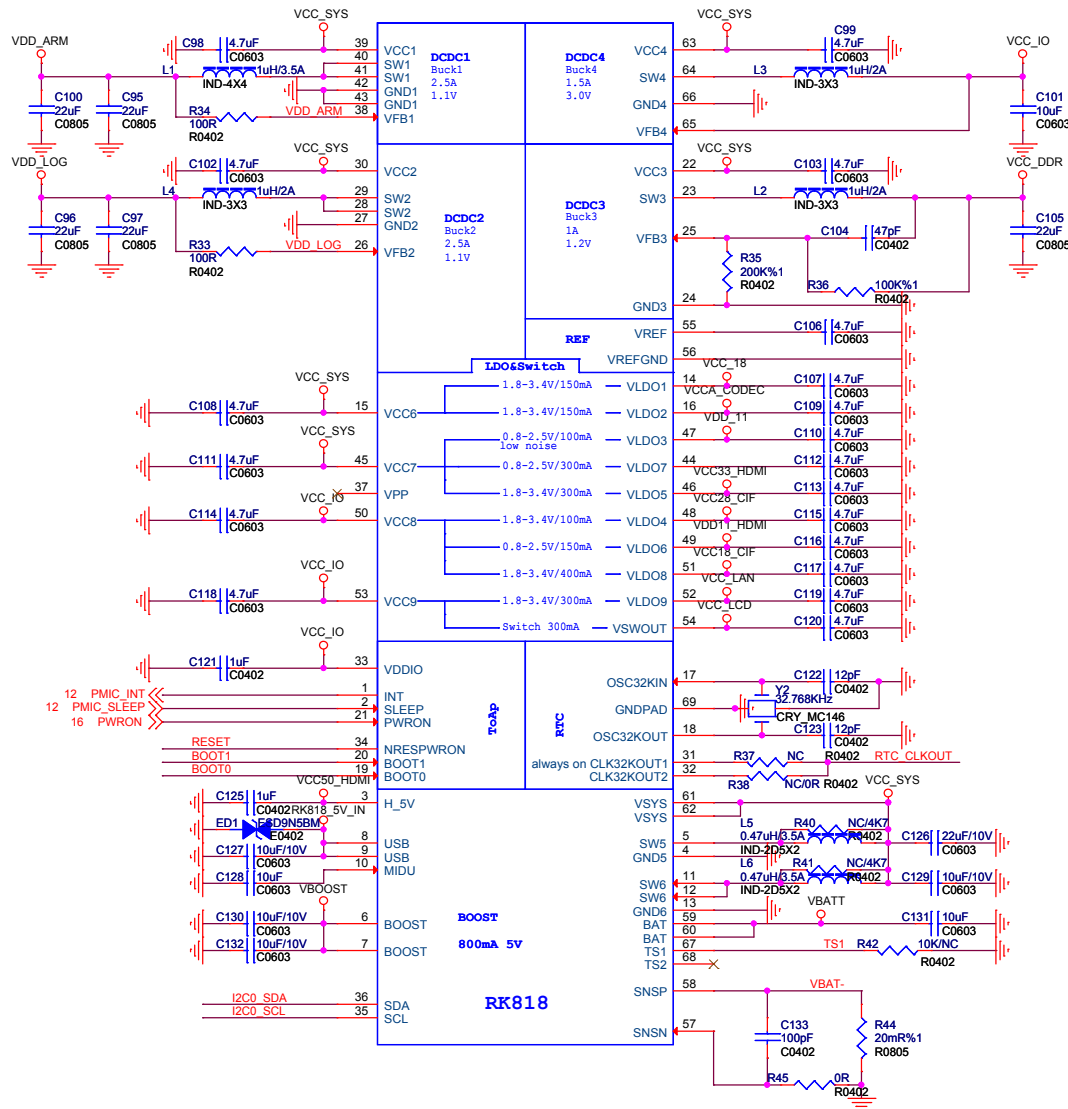

PCB POWER WIRE WIDTH INDICATE

	above 80 miles
	above 50 miles
	above 30 miles
	above 12 miles
	Under needs

PowerName	PMU Channel	TIMER (2ms)	Default ON/OFF	default voltage	sleep ON/OFF
VDD_ARM	DCDC1	soltt:3	ON	1.1V	ON
VDD_LOG	DCDC2	soltt:1	ON	1.1V	ON
VCC_DDR	DCDC3	soltt:4	ON	DDR3 1.35V LPDDR 1.2V	ON
VCC_IO	DCDC4	soltt:1	ON	3.0V	ON
VCC_18	VLD01	X	OFF	3.3V	OFF
VCC8_CODEC	VLD02	X	OFF	3.0V	OFF
VDD_11	VLD03	soltt:1	ON	1.1V	ON
VCC28_CIF	VLD04	soltt:2	ON	2.5V	OFF
VCC33_HDMI	VLD05	soltt:1	ON	3.0V	ON
VDD11_HDMI	VLD06	X	OFF	1.2V	OFF
VCC18_CIF	VLD07	soltt:2	ON	1.8V	OFF
VCC18_CIF	VLD08	X	OFF	1.8V	OFF
VCC_LAN	VLD09	soltt:4	ON	3.0V	OFF
VCC_LCD	VSR0U1	X	OFF	X	OFF

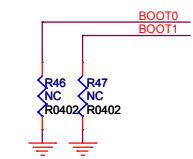
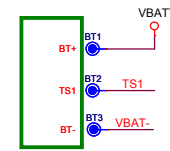
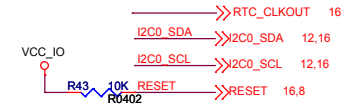

www.t-firefly.com

Title: **Power-RK818**

File: **FirePrime** REV: V10

Create Date: Monday, June 01, 2015 Page Num: 15

Modify Date: Wednesday, June 10, 2015 Page Total: 16

Connector

J15
2013311-2

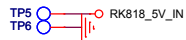
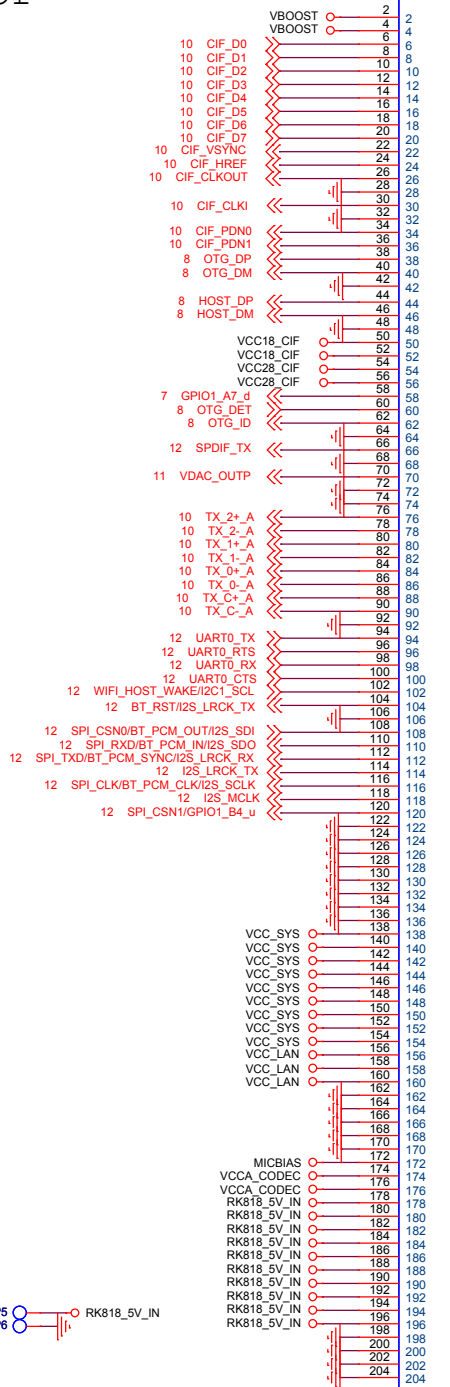

J16
2013311-1

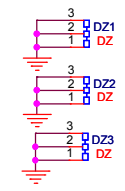
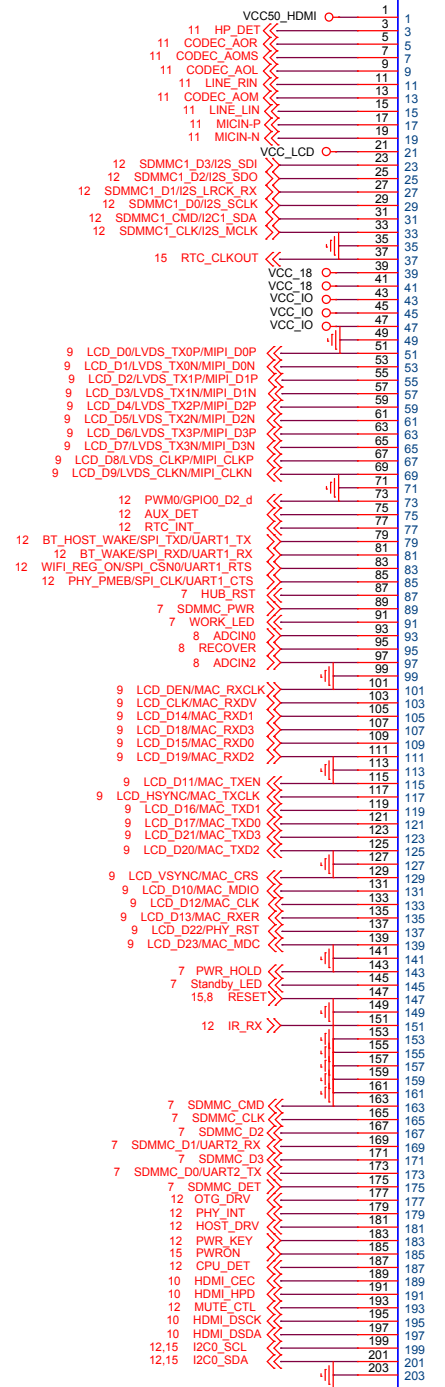

- ⊗ MASK1
- ⊗ MASK2
- ⊗ MASK3
- ⊗ MASK8
- ⊗ MASK9
- ⊗ MASK10

U50
Firefly
T-CHIP_LOGO

www.t-firefly.com

Title: Connector

File: FirePrime REV: V10

Create Date: Monday, June 01, 2015	Page Num: 16
Modify Date: Wednesday, June 10, 2015	Page Total: 16