

CONTENT INDEXING

- 01. INDEX
- 02. Change List
- 03. Block Diagram
- 04.DC_IN/IR
- 05.USB Port
- 06.TF card/RTC
- 07.10/100/1000M-PHY
- 08.AUDIO/CVBS
- 09.WIFI/BT-AP6XXX
- 10.HDMI OUT
- 11.SPDIFF/KEY
- 12.Connector1
- 13.Connector2

PCB POWER WIRE WIDTH INDICATE

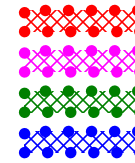

No indicate

above 80 miles

above 50 miles

above 30 miles

above 16 miles

Under needs

4 LAYERS PCB STACK

TOP	Prepreg 3313*1 4.0MIL(0.10mm)	Hoz(18um) + plating copper(18um)
GND	Adjust	1oz(35um)
POWER	Prepreg 3313*1 4.0MIL(0.10mm)	1oz(35um)
BOTTOM		Hoz(18um) + plating copper(18um)



www.t-firefly.com

Title: Index

File: FirePrime

REV: V10

Create Date: Monday, June 01, 2015

Page Num: 1

Modify Date: Wednesday, June 10, 2015

Page Total: 13

Version	Date	Author	Change Note	Note
V00	20150130	HWQ	The first edit.	
V01	20150312	HWQ	Increase pull-up resistor for SDIO1.	
V10	20150611	HWQ	1. HDMI's power was changed. 2.GPIO2_A5 and GPIO0_D6 exchange.	

		www.t-firefly.com	
Title: Change List			
File: FirePrime			REV: V10
Create Date: Monday, June 01, 2015		Page Num: 2	
Modify Date: Monday, June 15, 2015		Page Total: 13	

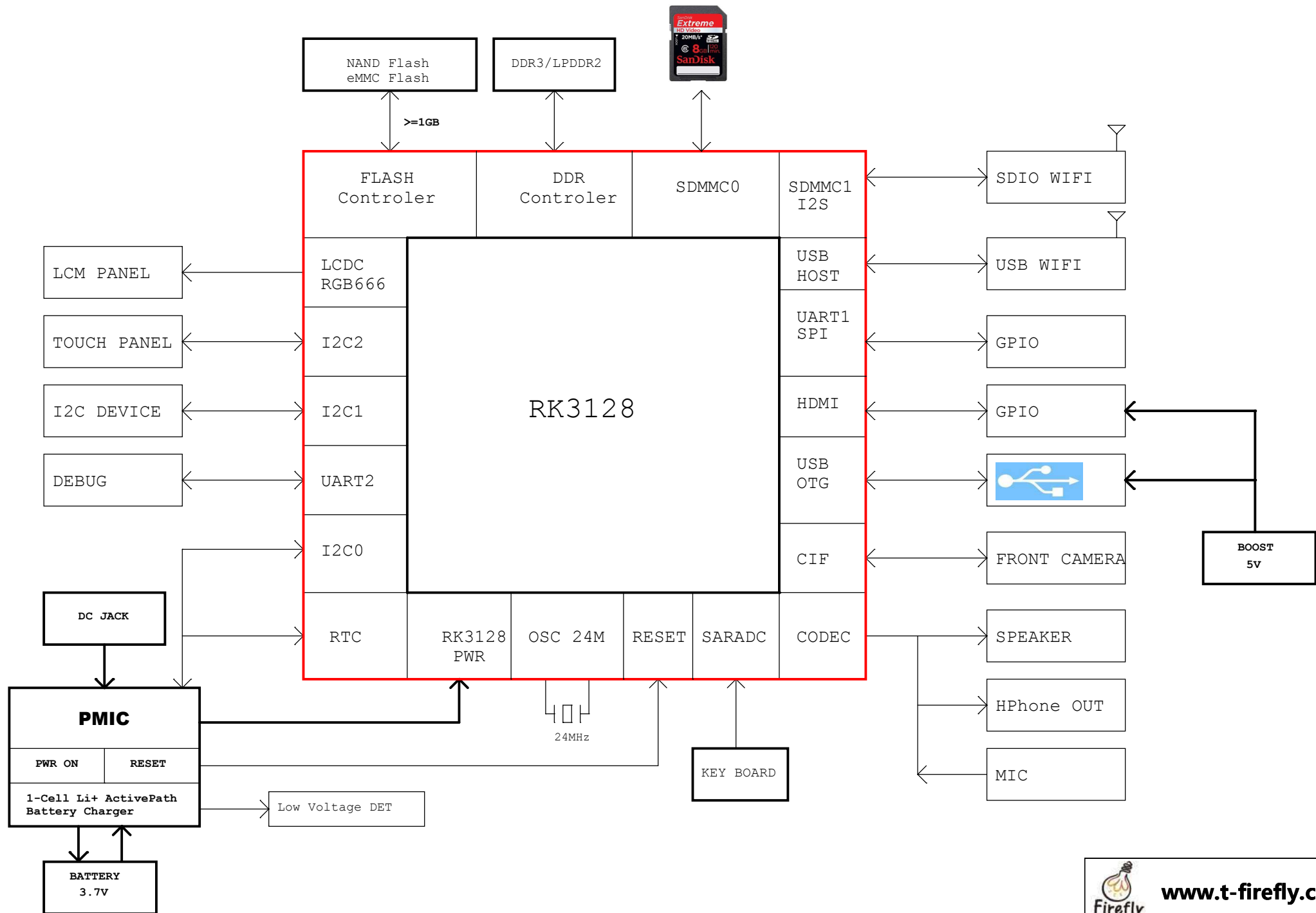

DC_IN

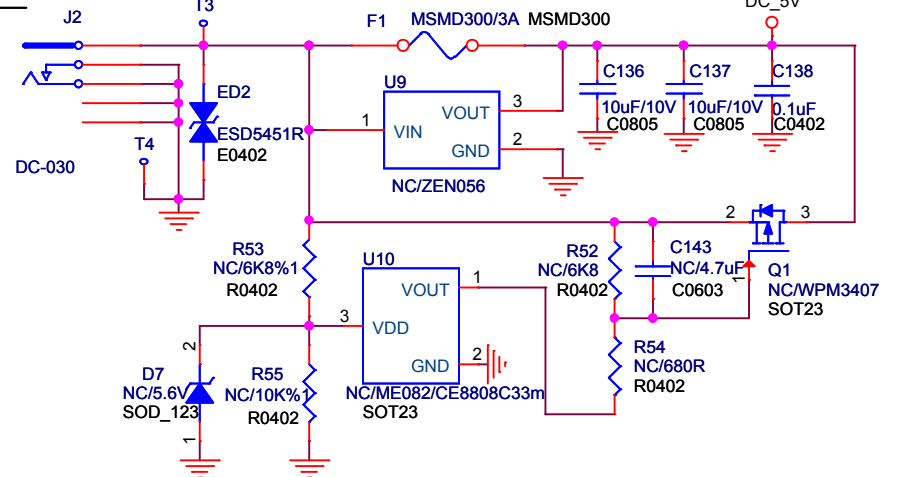

POWER_CTL

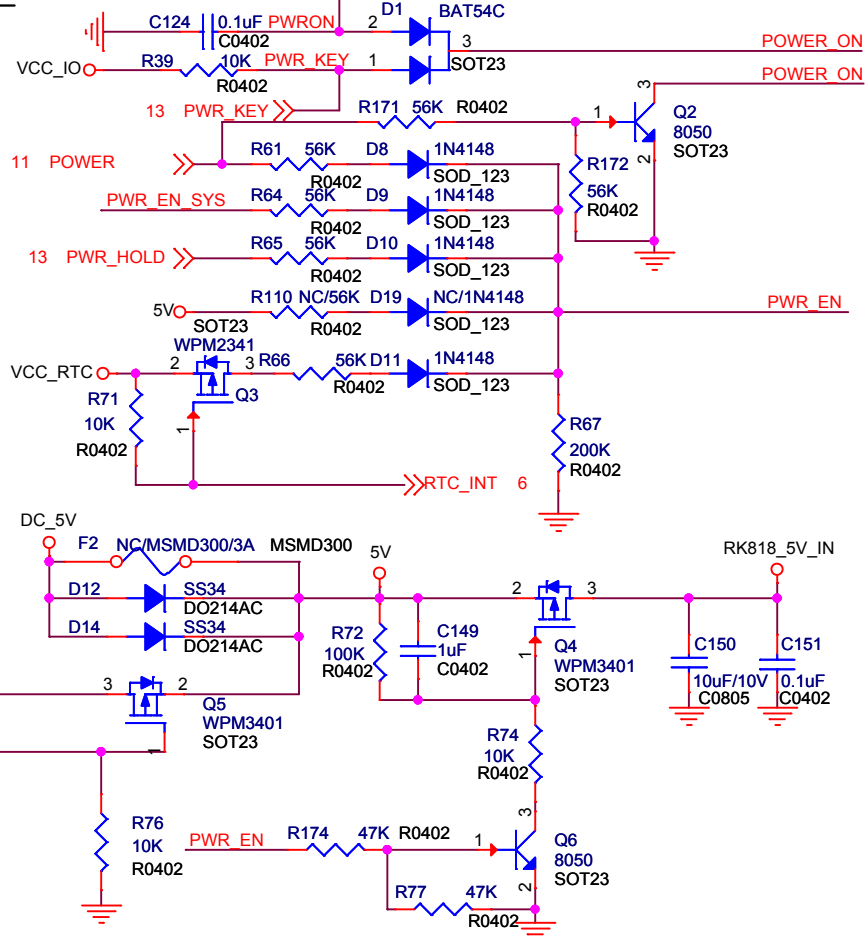

MCU

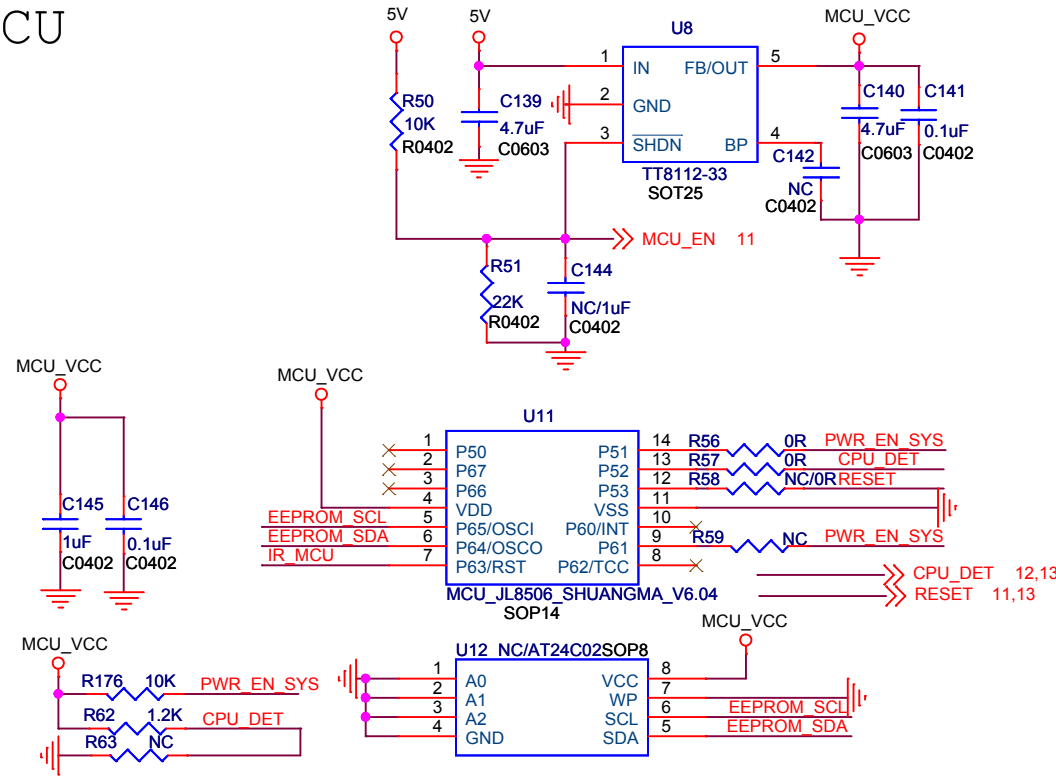

IR RECEIVE

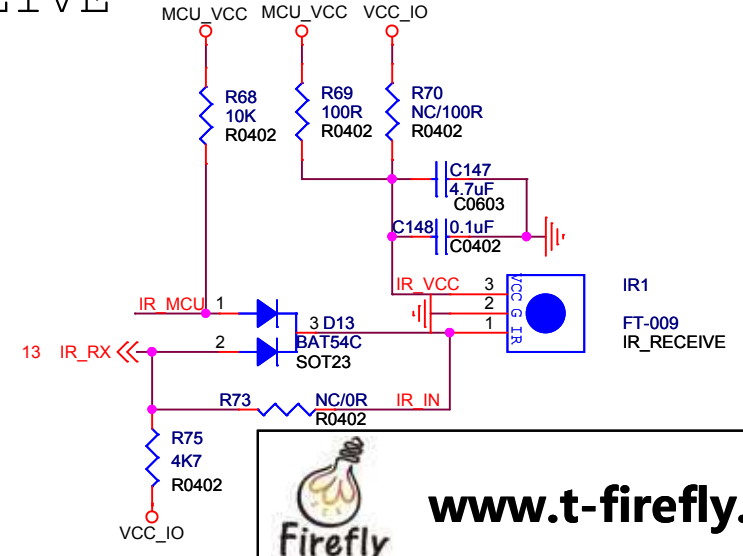

Title: DC IN/IR		REV: V10
File: FirePrime		
Create Date: Monday, June 01, 2015	Page Num: 4	
Modify Date: Wednesday, June 10, 2015	Page Total: 13	

BOOST/HOST, OTG_POWER

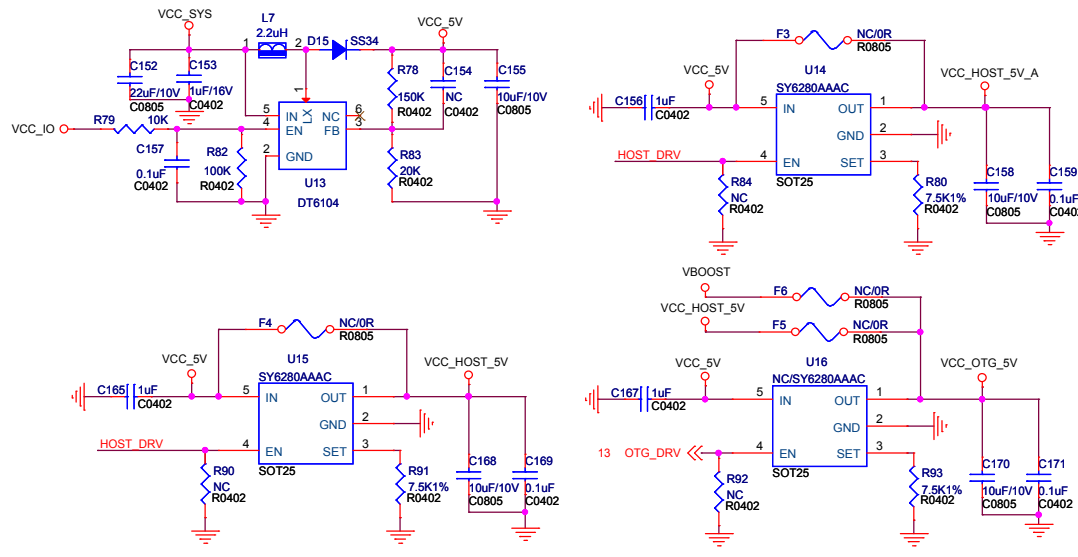

OTG PORT

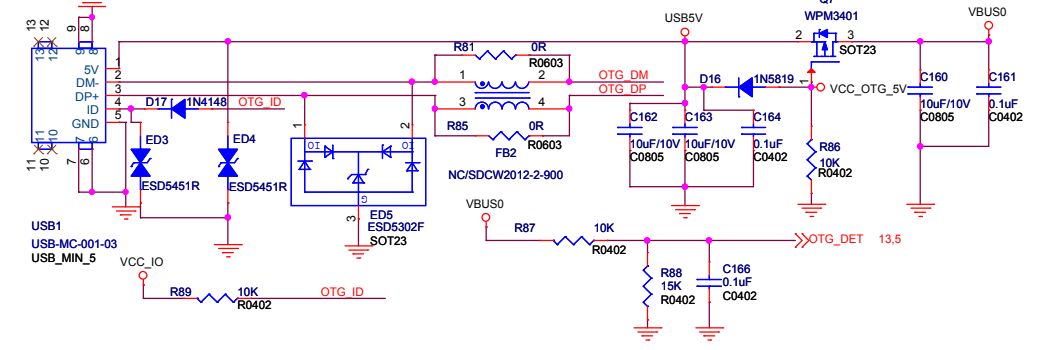

HOST PORT

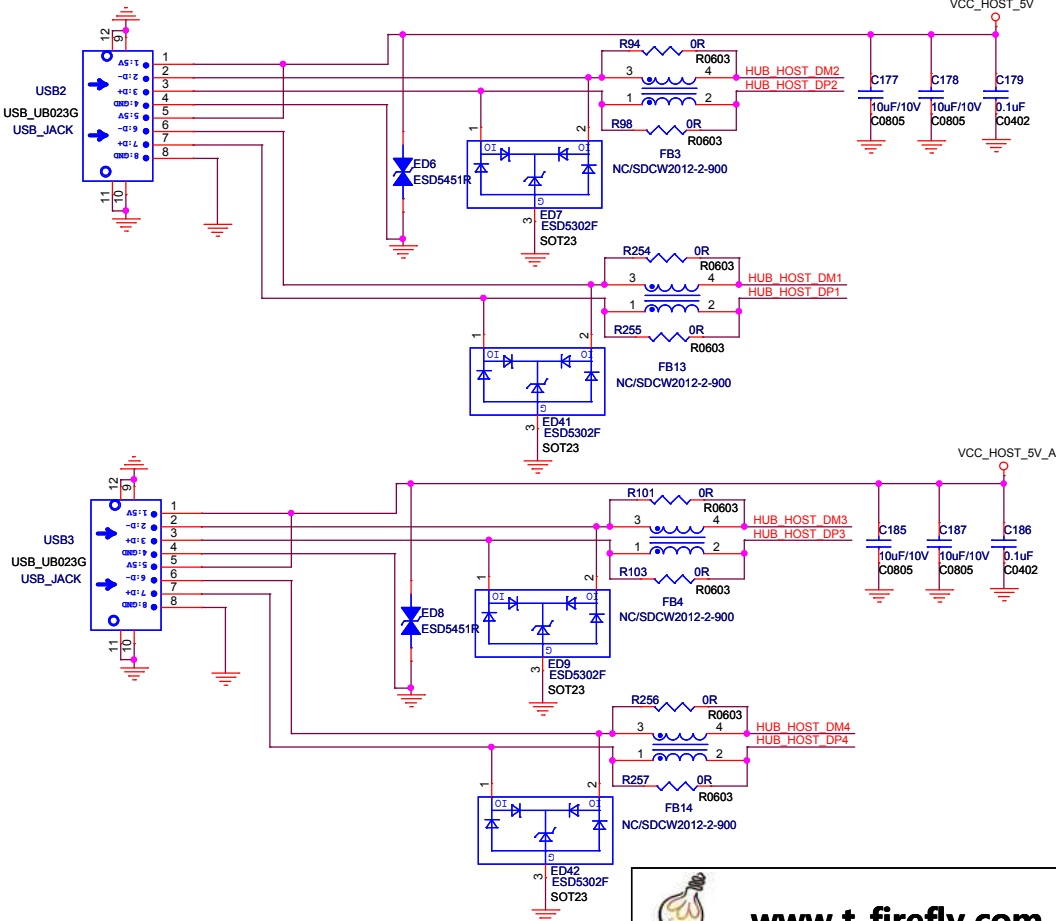

HUB

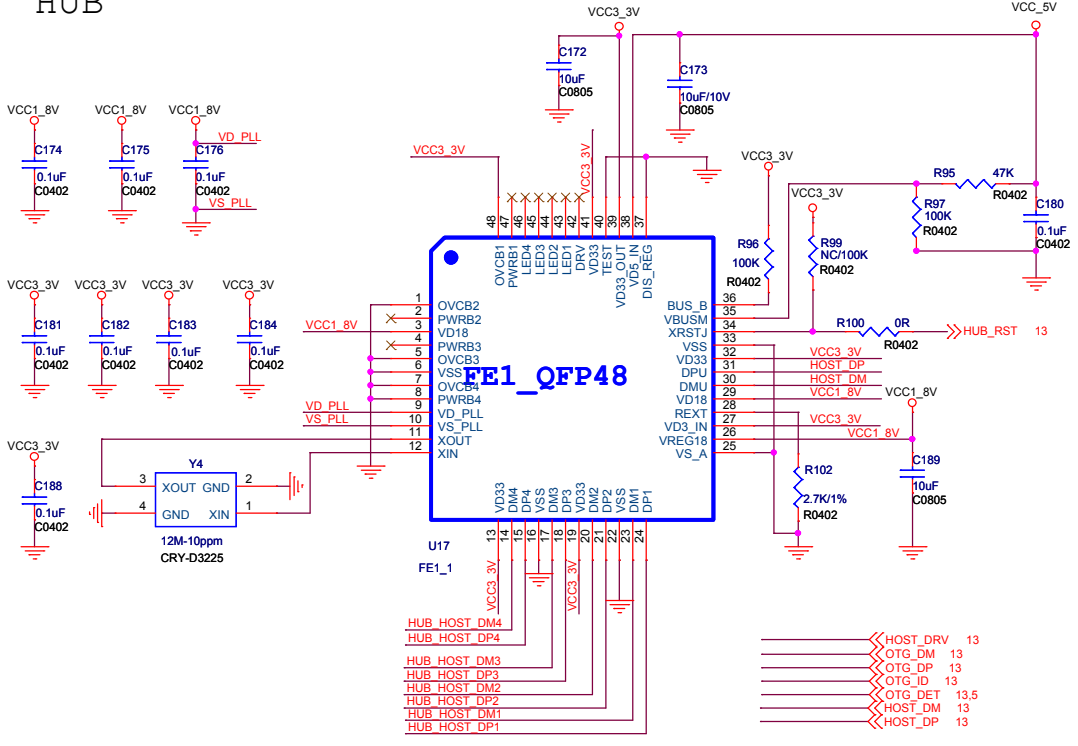

Title: USB Port		REV: V10
File: FirePrime		
Create Date: Monday, June 01, 2015	Page Num: 5	
Modify Date: Wednesday, June 10, 2015	Page Total: 13	

TF CARD

RTC

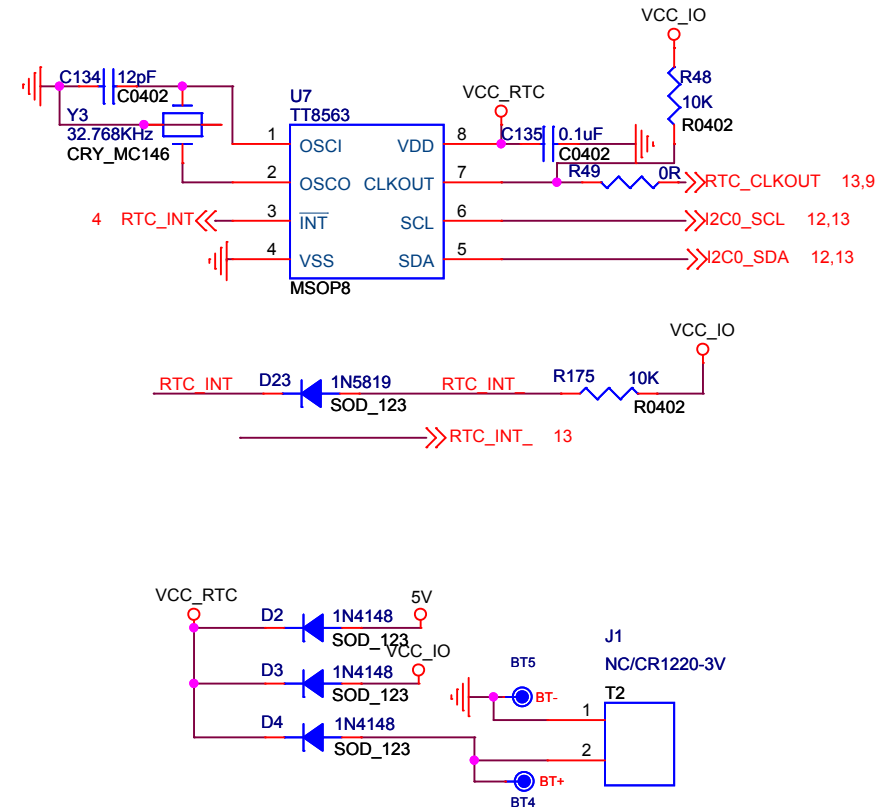
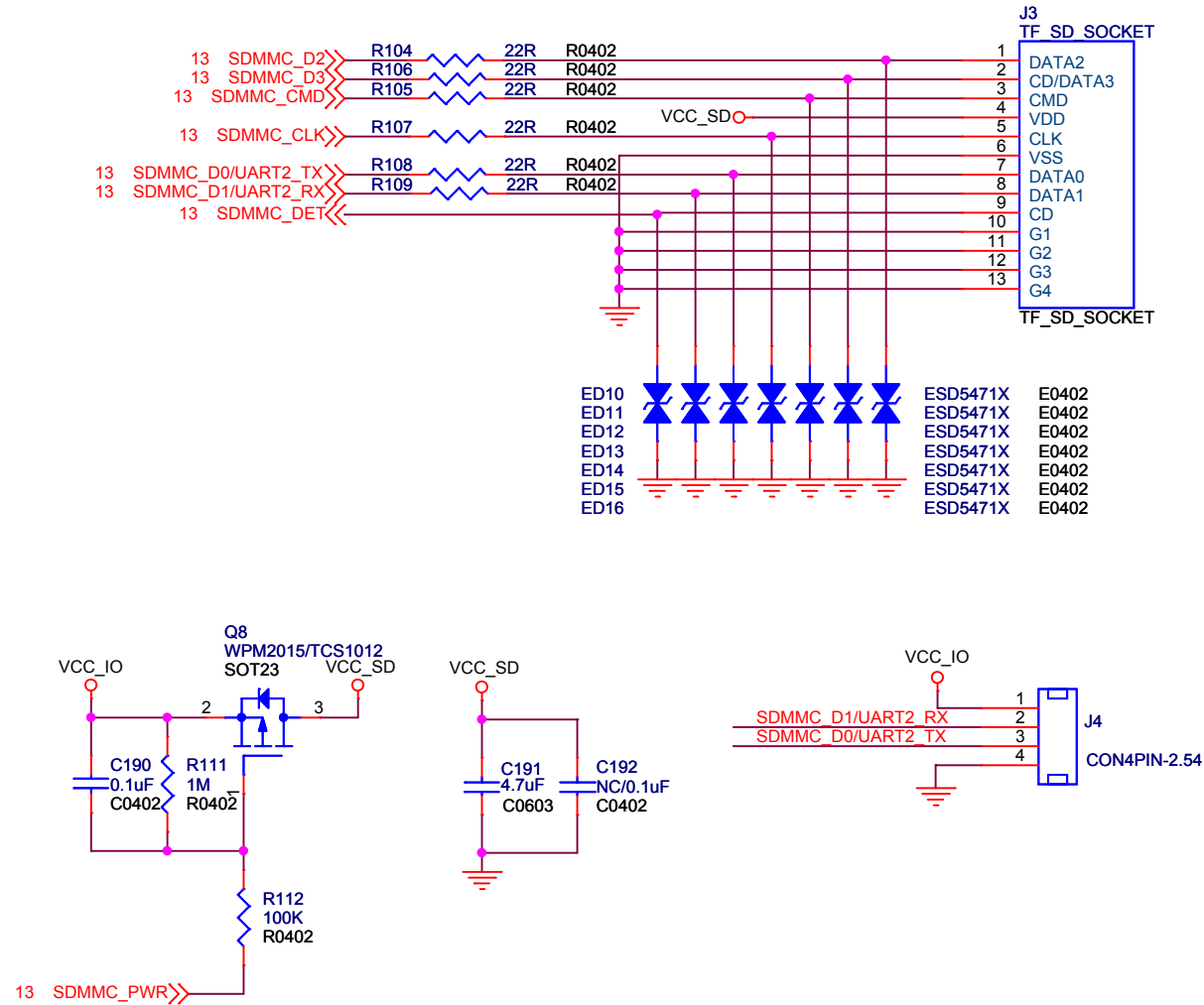

Title: TF card/RTC	
File: FirePrime	REV: V10
Create Date: Monday, June 01, 2015	Page Num: 6
Modify Date: Monday, June 15, 2015	Page Total: 13

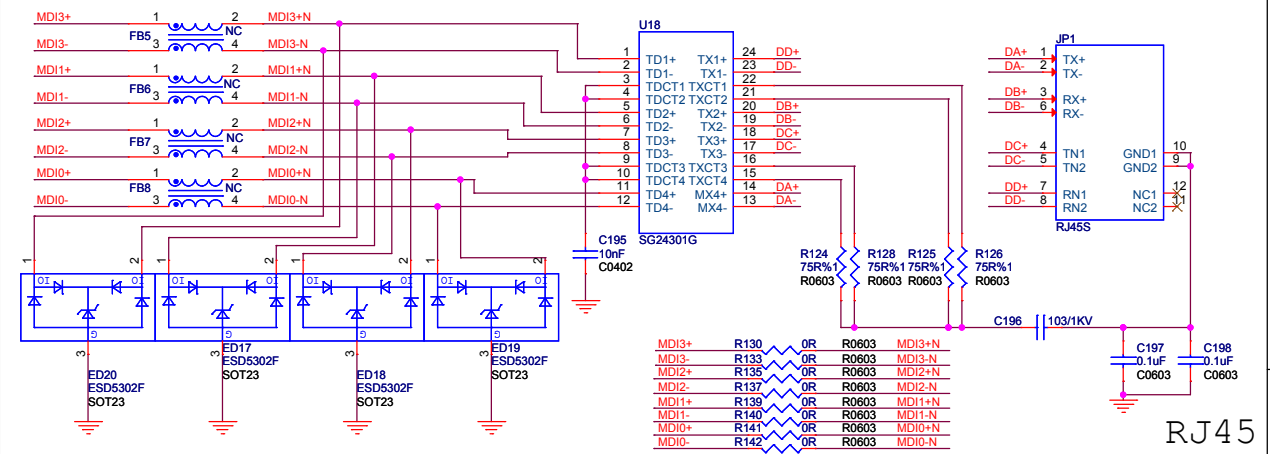
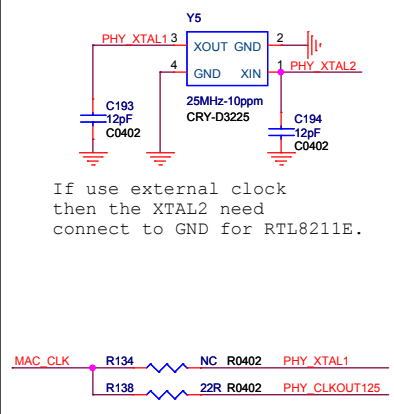
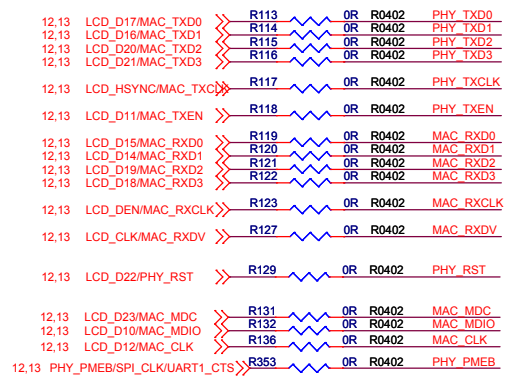

PHY

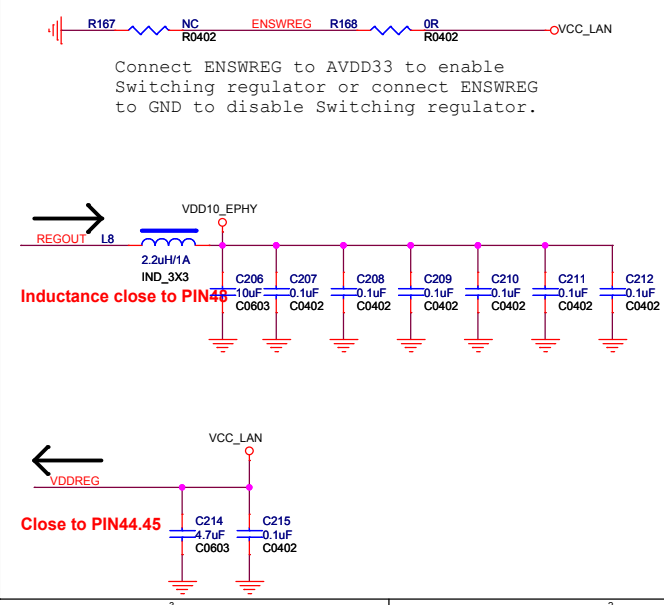
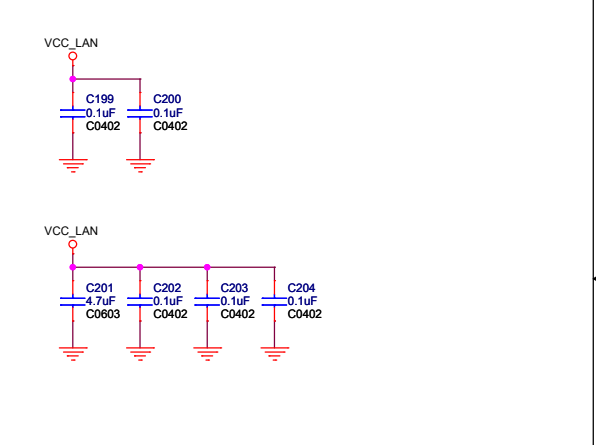
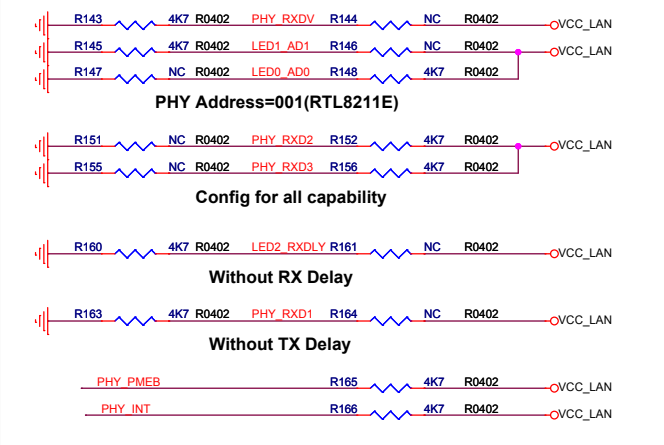
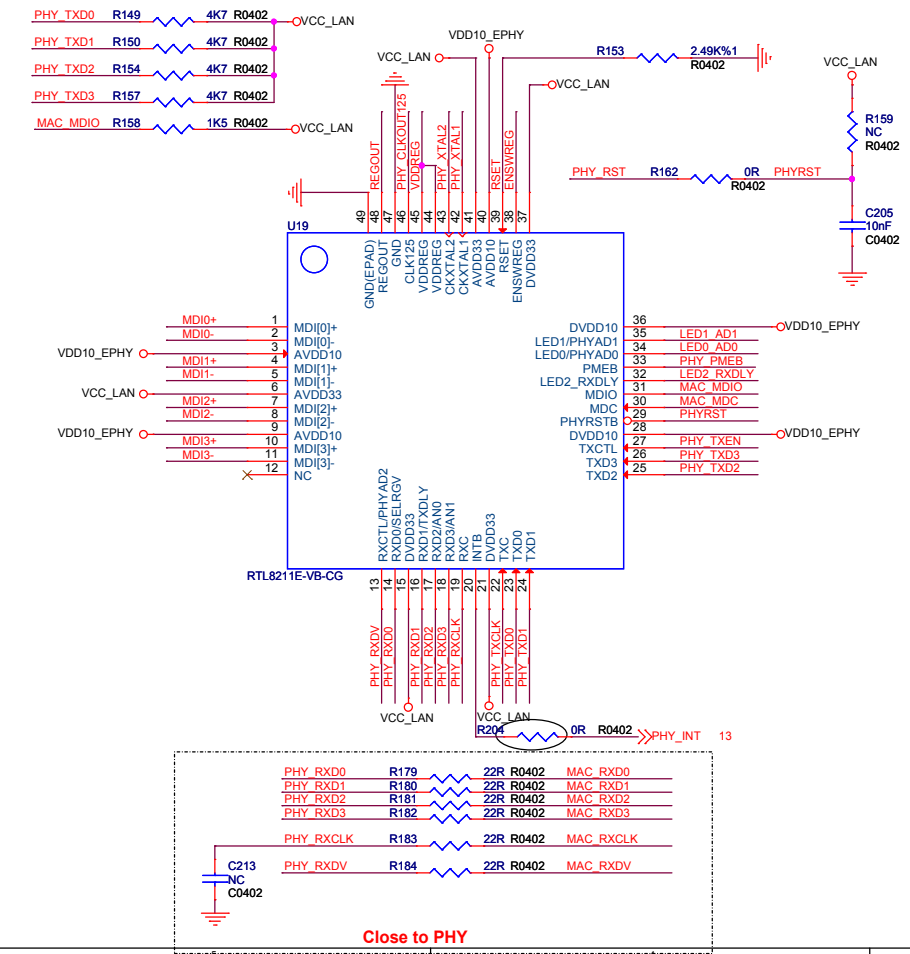

Pull down for 2.5V RGMII(RTL8211D/8211E)

Pull up for 3.3V RGMII (RTL8211D/8211E)

Pull up 1.5 /1.8V RGMII (RTL8211E-VL only)

LED1 AD1

LED0 AD0

VCC_LAN

510R R0402

510R R0402

www.t-firefly.com

Firefly

Title: 10/100/1000M-PHY

File: FirePrime

REV: V10

Create Date: Monday, June 01, 2015

Page Num: 7

Modify Date: Wednesday, June 10, 2015

Page Total: 13

2-Vrms Audio Line Driver

- >> CODEC_AOL 13
- >> CODEC_AOR 13
- >> CODEC_AOMS 13
- >> CODEC_AOM 13
- >> HP_DET 13
- >> MICIN-N 13
- >> MICIN-P 13
- >> VDACC_OUTP 13
- >> LINE_LIN 13
- >> LINE_RIN 13
- >> AUX_DET 13

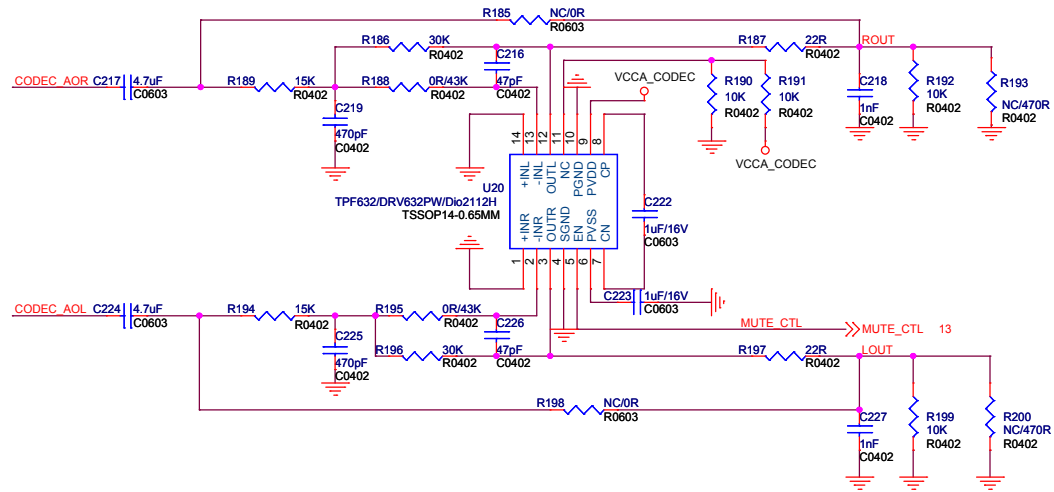
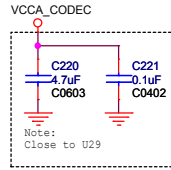

MIC

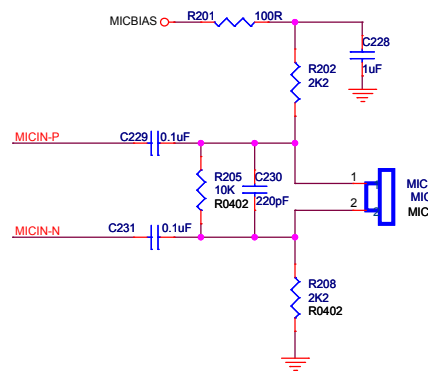

HEADPHONE

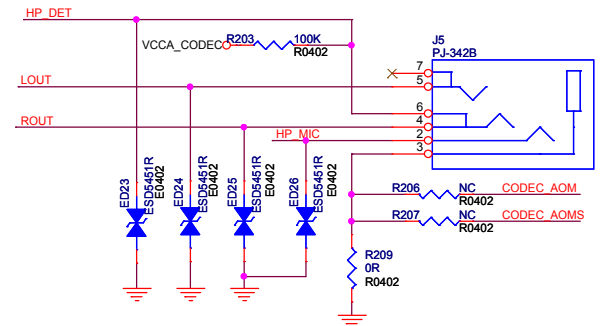
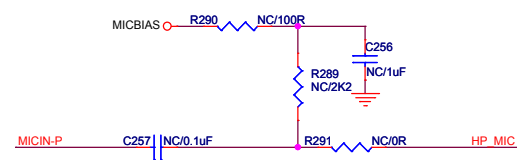

CVBS&LINE_OUT&LINE_IN

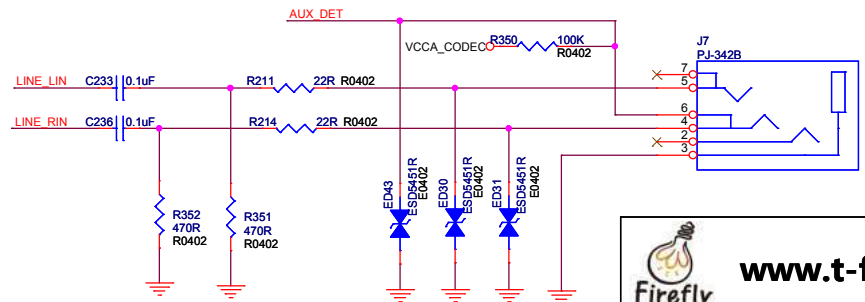
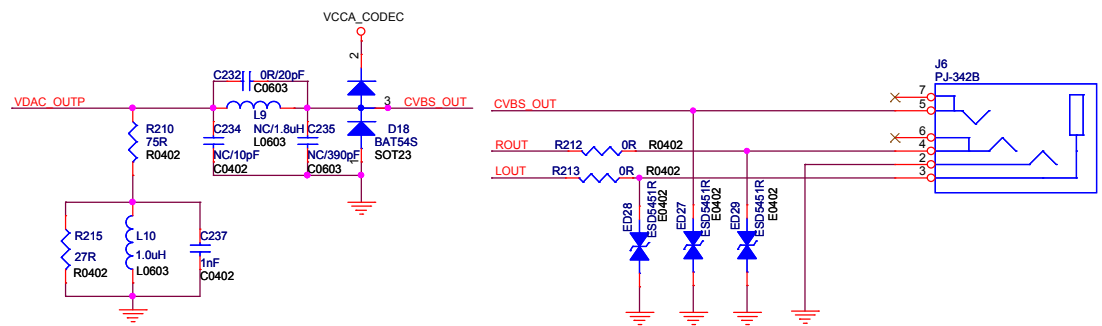



www.t-firefly.com

Title: AUDIO/CVBS		REV: V10
File: FirePrime		
Create Date: Monday, June 01, 2015	Page Num: 8	
Modify Date: Monday, June 15, 2015	Page Total: 13	

Note:
Adjusted the load capacitance according to the crystal specification.

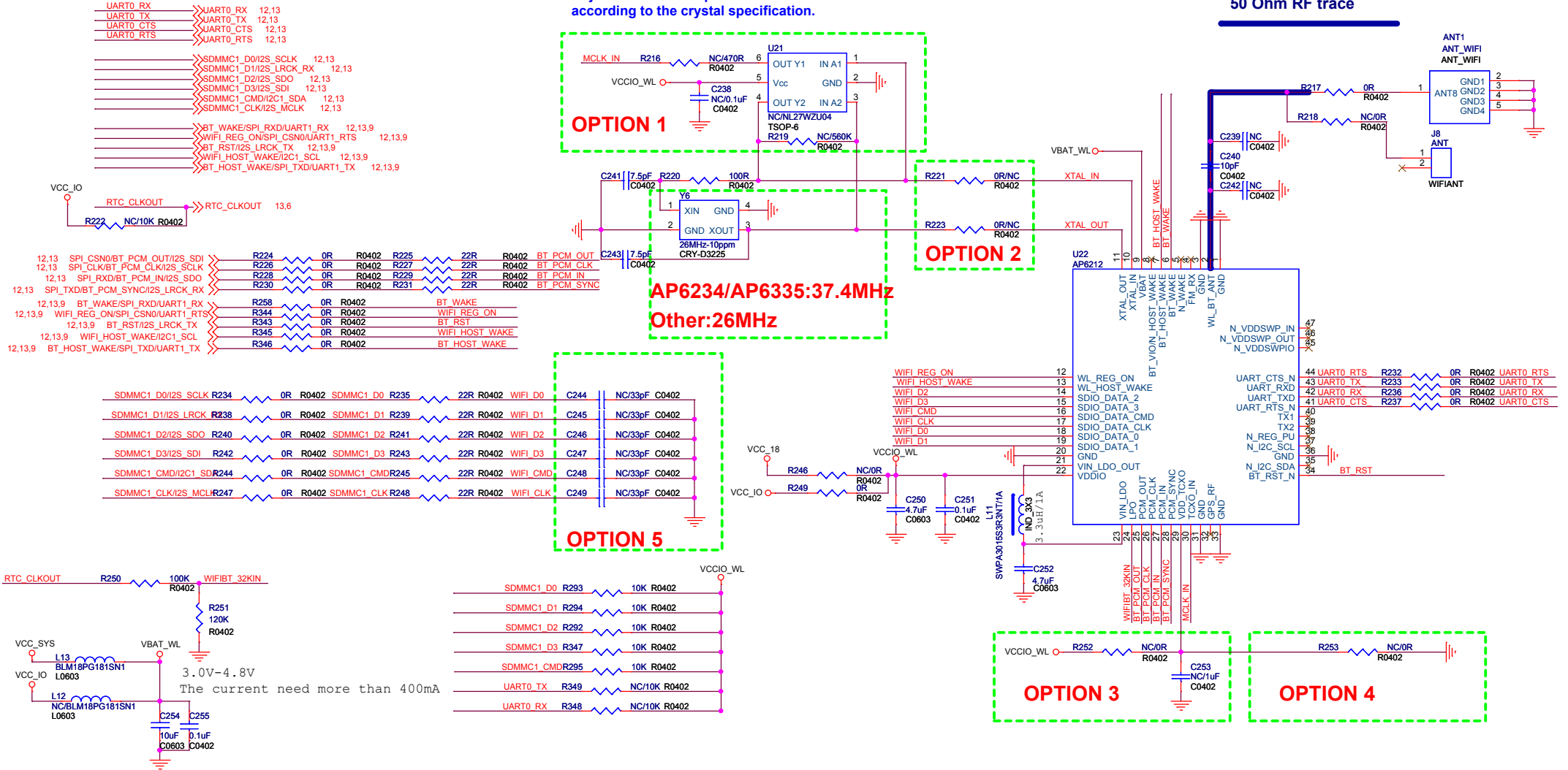
50 Ohm RF trace



OPTION	WIFI				BT4.0	Crystals	VDDIO
	a	b/g/n	ac	5GHz			
AP6181		Yes				26MHz	1.71-3.6V
AP6210		Yes			Yes	26MHz	1.71-3.6V
AP6212		Yes			Yes	26MHz	1.71-3.6V
AP6330	Yes	Yes		Yes	Yes	26MHz	1.2-2.9V
AP6335 (Default)	Yes	Yes	Yes	Yes	Yes	37.4MHz	1.71-3.63V

OPTION	1	2	3	4	5
	AP6181	No	Yes	No	No
AP6210	Yes	No	Yes	No	No
AP6212	No	Yes	No	No	No
AP6330	No	Yes	No	No	No
AP6335 (Default)	No	Yes	No	Yes	Yes

Note:
Yes: 框内要贴
No: 框内不贴

 **www.t-firefly.com**

Title: WIFI/BT-AP6XXX
File: FirePrime
REV: V10

Create Date: Monday, June 01, 2015 **Page Num:** 9
Modify Date: Wednesday, June 10, 2015 **Page Total:** 13

HDMI_OUT

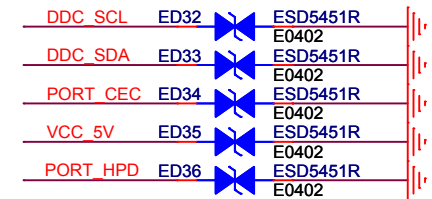
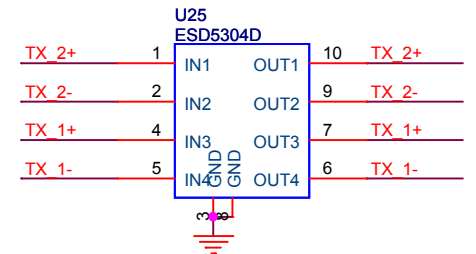
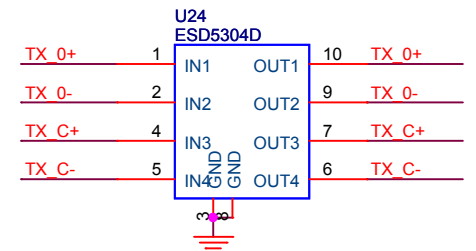
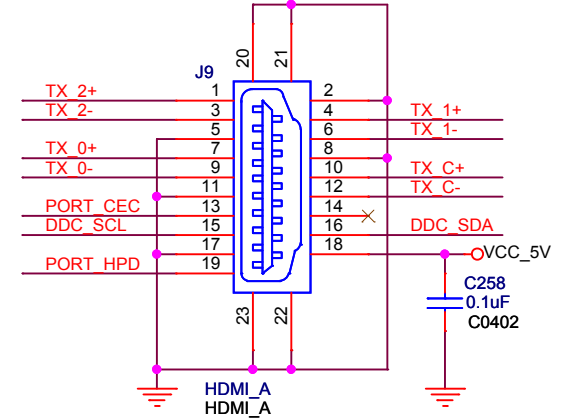
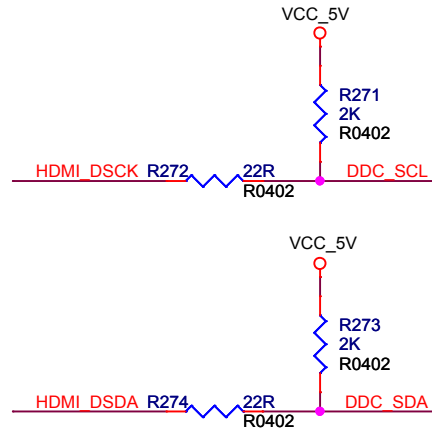
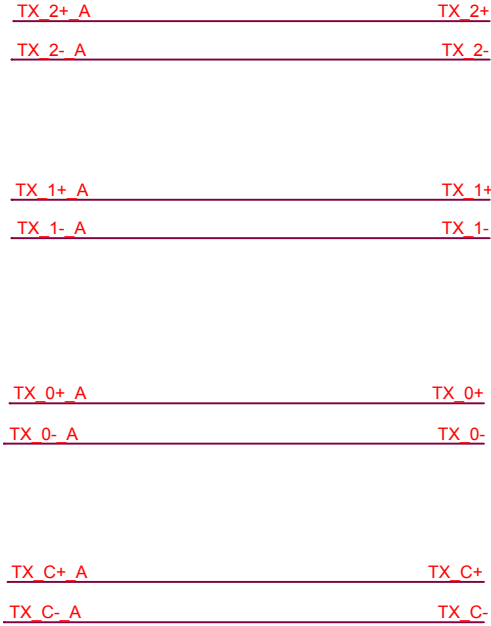
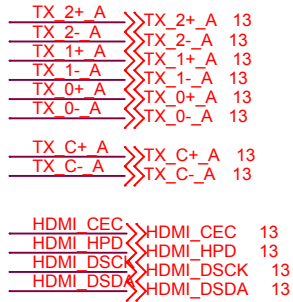
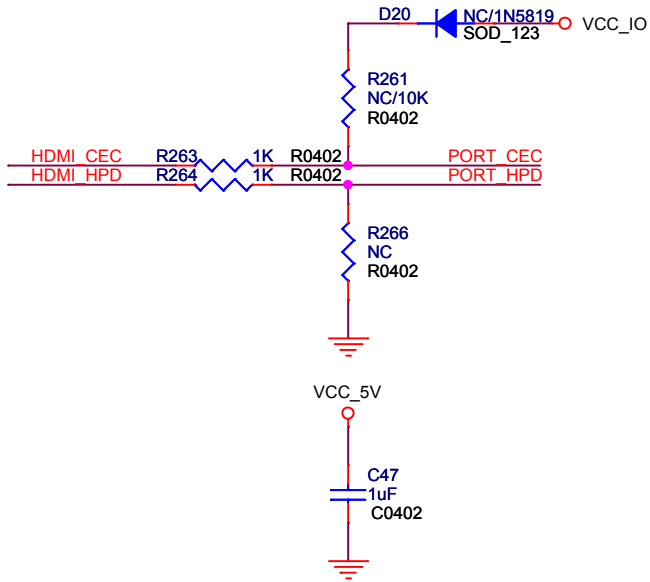



www.t-firefly.com

Title: HDMI OUT

File: FirePrime REV: V10

Create Date: Monday, June 01, 2015 Page Num: 10

Modify Date: Monday, June 15, 2015 Page Total: 13

SPDIF

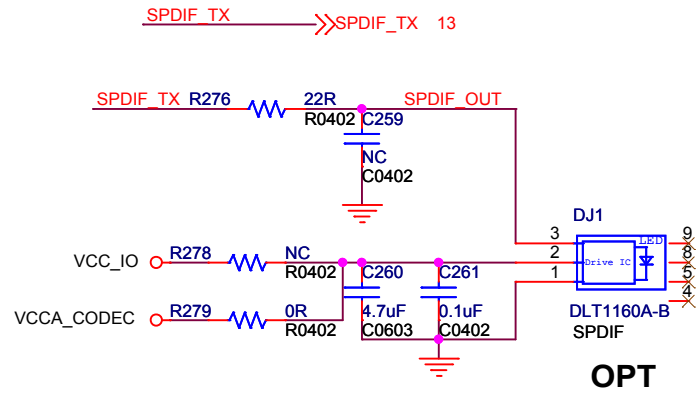

RESET

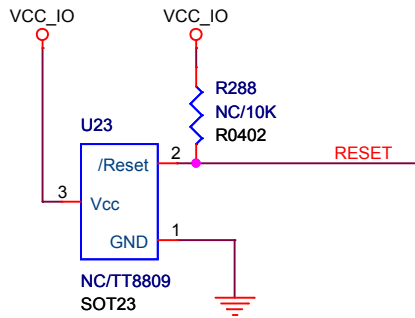

LED

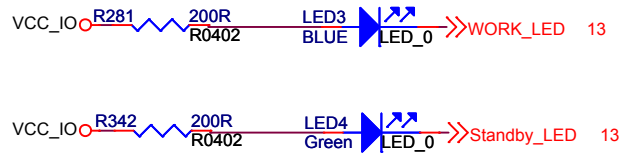

KEY

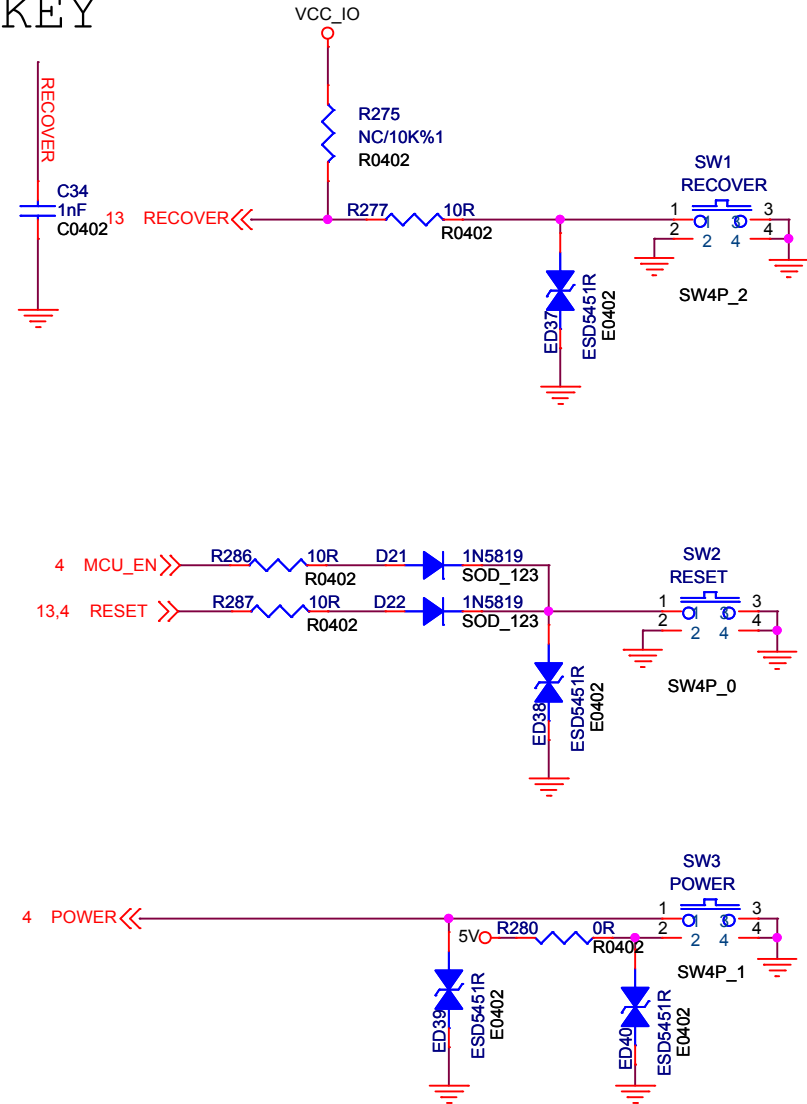

Title: SPDIF/KEY/LED

File: FirePrime

REV: V10

Create Date: Monday, June 01, 2015

Page Num: 11

Modify Date: Monday, June 15, 2015

Page Total: 13

Connector

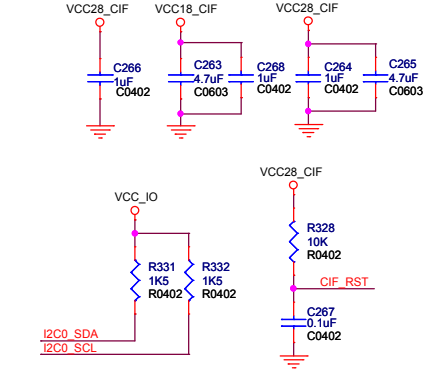
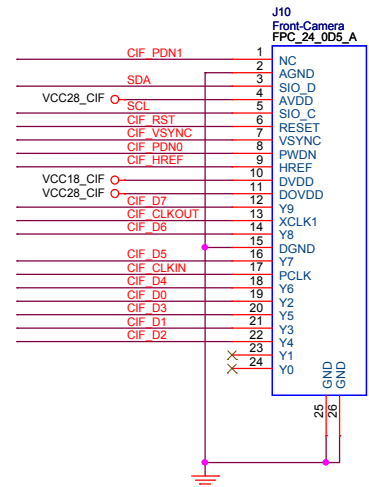
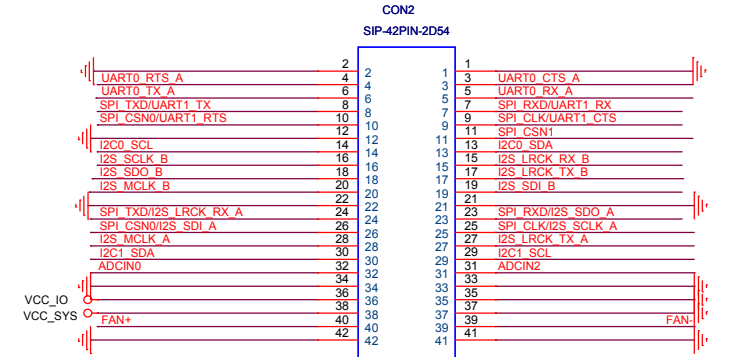
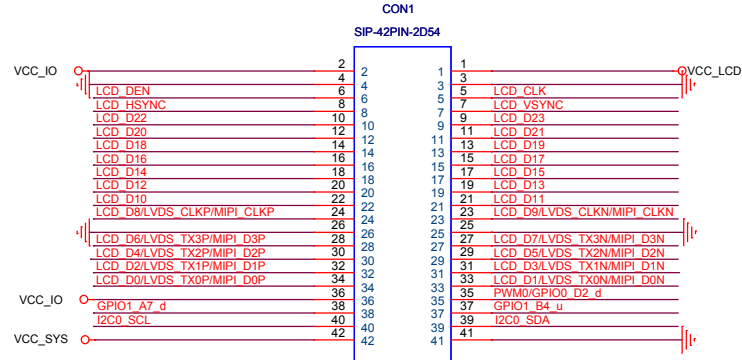
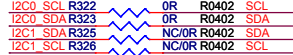
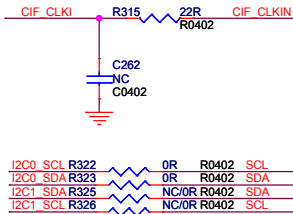
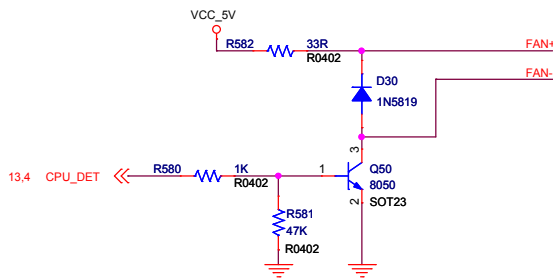
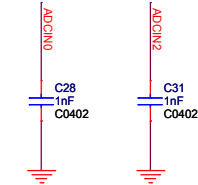
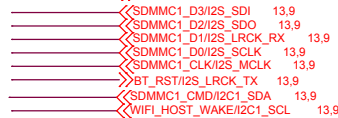
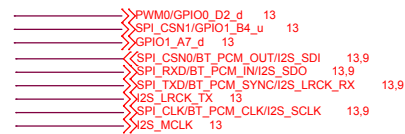
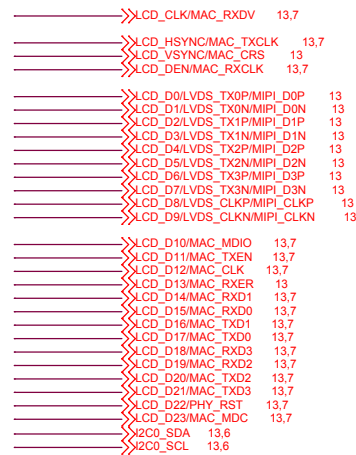

connector

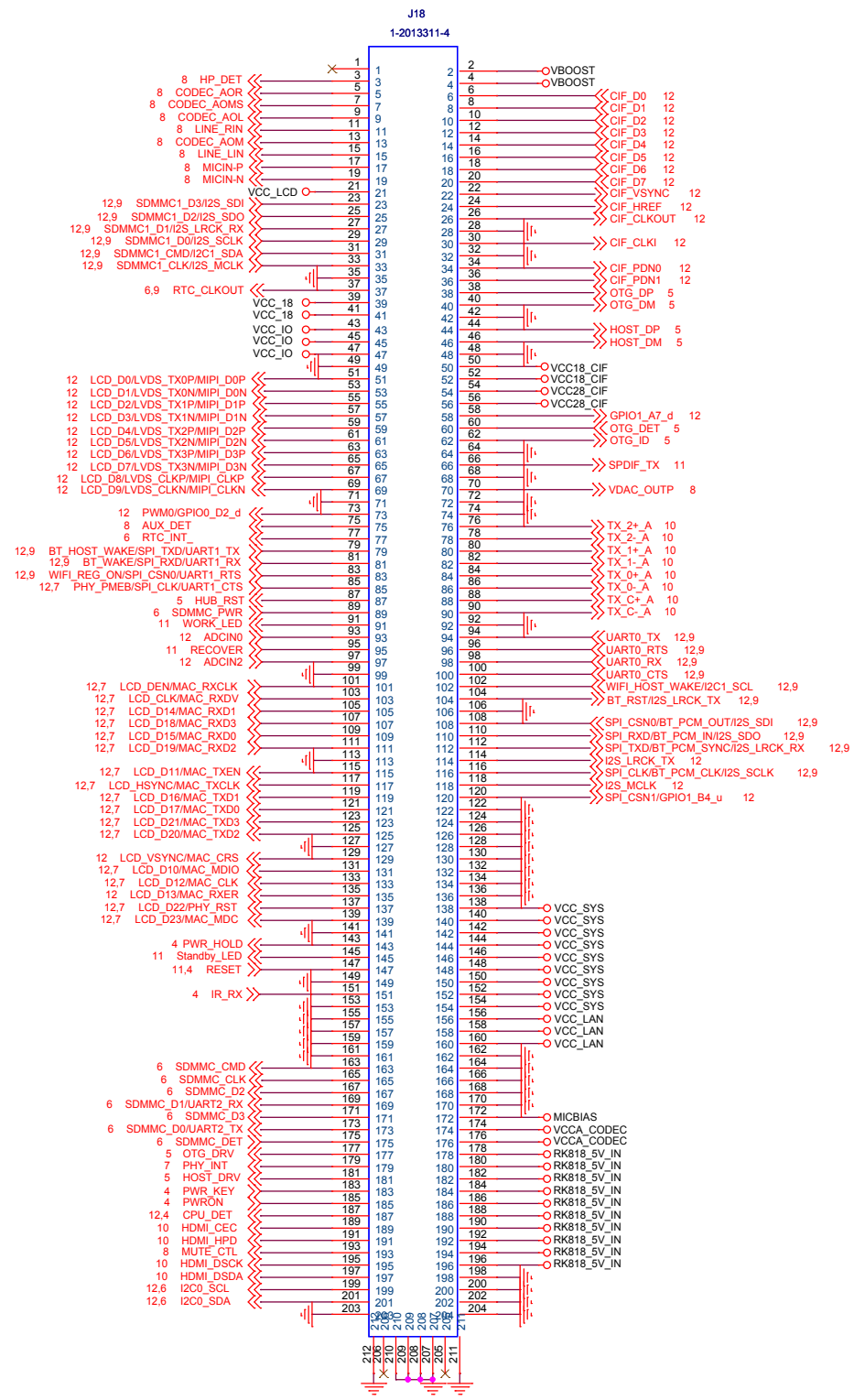

U51
Firefly
T-CHIP_LOGO

- MASK5
- MASK6
- MASK7
- MASK8
- MASK9
- MASK10
- MASK11
- MASK12
- MASK13

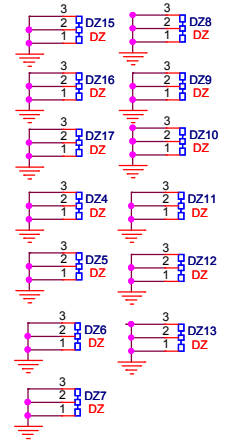

Title: Connector2		REV: V10
File: FirePrime		
Create Date: Monday, June 01, 2015	Page Num: 13	
Modify Date: Wednesday, June 10, 2015	Page Total: 13	