

REV	Description	DATE	BY
v1	First release PCB version is v1	3/6/2015	QXN

PAGE NO.	SCHEMATIC PAGE
1	COVER PAGE
2	POWER MANAGEMENT
3	PROCESSOR 1 OF 3, JTAG HEADER
4	PROCESSOR 2 OF 3, UAB PORTS
5	PROCESSOR 3 OF 3
6	LED, CONFIGURATION AND BUTTON
7	DDR3 MEMORY
8	eMMC FLASH
9	10/100 ETHERNET
10	EXP CONN, uSD

This work is licensed under the Creative Commons Attribution 4.0 International License.  
 To view a copy of this license, visit  
<http://creativecommons.org/licenses/by-sa/4.0>

This schematic is **\*NOT SUPPORTED\*** and DOES NOT constitute a reference design. Only Community support is allowed via resources at [BeagleBoard.org/discuss](http://BeagleBoard.org/discuss).

THERE IS NO WARRANTY FOR THIS DESIGN , TO THE EXTENT PERMITTED BY APPLICABLE LAW. EXCEPT WHEN OTHERWISE STATED IN WRITING THE COPYRIGHT HOLDERS AND/OR OTHER PARTIES PROVIDE THE DESIGN IS WITHOUT WARRANTY OF ANY KIND, EITHER EXPRESSED OR IMPLIED, INCLUDING, BUT NOT LIMITED TO, THE IMPLIED WARRANTIES OF MERCHANTABILITY AND FITNESS FOR A PARTICULAR PURPOSE. THE ENTIRE RISK AS TO THE QUALITY AND PERFORMANCE OF THE DESIGN IS WITH YOU. SHOULD THE DESIGN PROVE DEFECTIVE, YOU ASSUME THE COST OF ALL NECESSARY SERVICING, REPAIR OR CORRECTION.

		
<b>seeed</b> studio Grow the Difference		
Title	BeagleBone Green Cover Page	
Size	Document Number	Rev
B		v1
Date:	Thursday, June 04, 2015	Sheet 1 of 10

select wether the  
usb can provide 1A  
current power

4 PMIC\_POWER\_EN  
10 PWR\_BTN  
4,10 I2C0\_SCL  
4,10 I2C0\_SDA

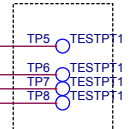
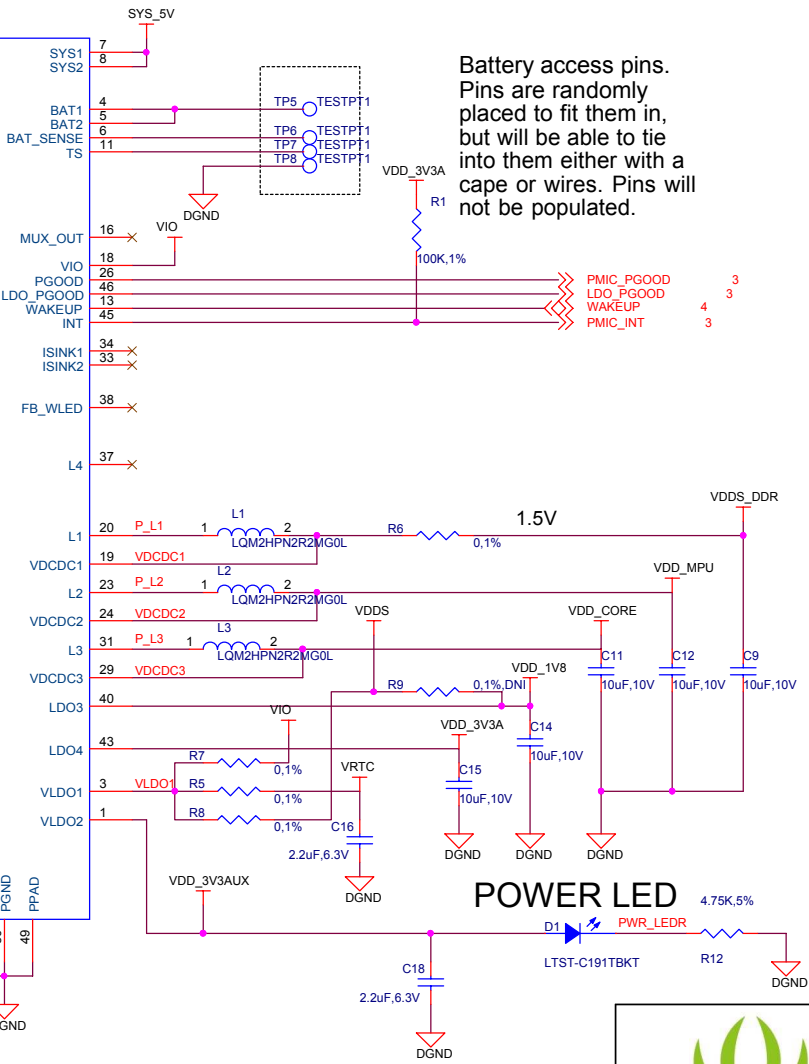
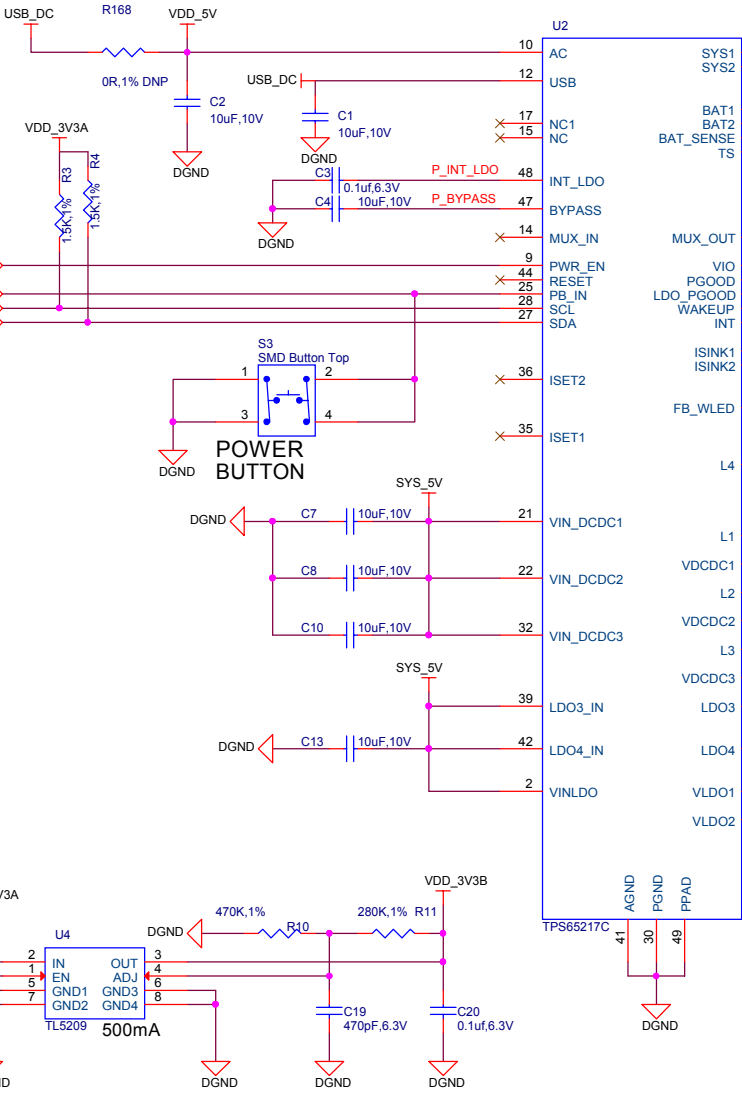
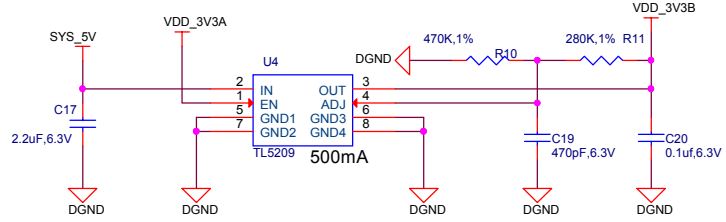
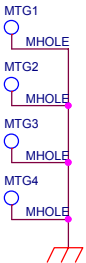

Battery access pins.  
Pins are randomly  
placed to fit them in,  
but will be able to tie  
into them either with a  
cape or wires. Pins will  
not be populated.

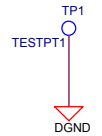

Title: BeagleBone Green Power Management		
Size: B	Document Number	Rev: v1
Date: Monday, July 27, 2015	Sheet 2 of 10	

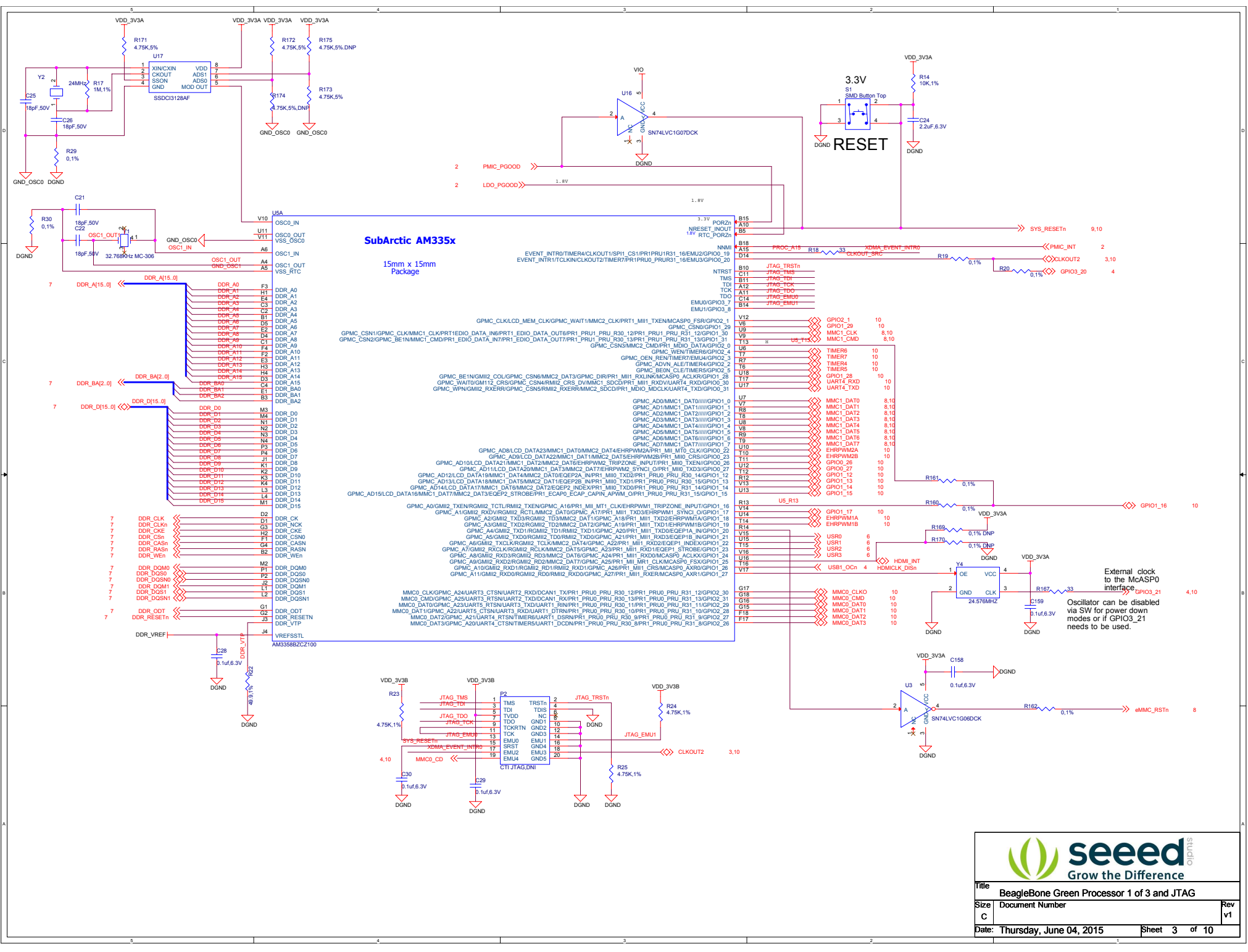

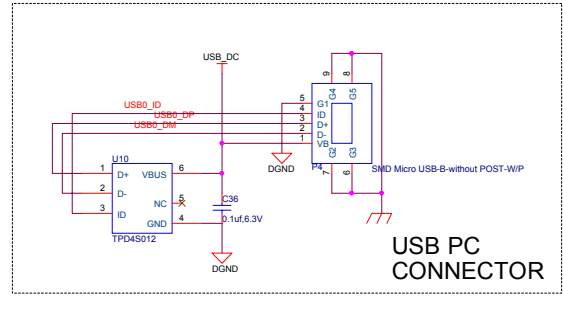
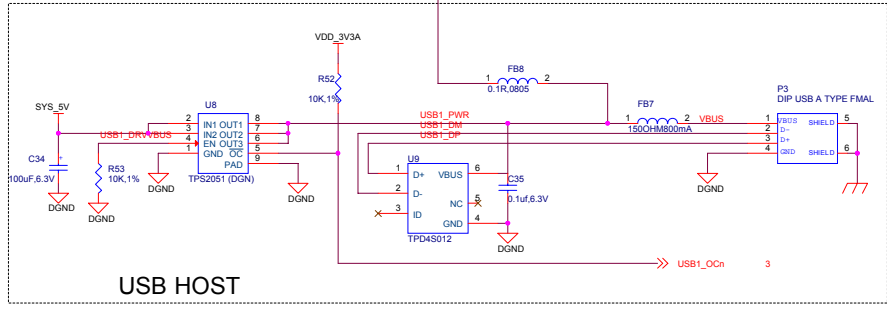

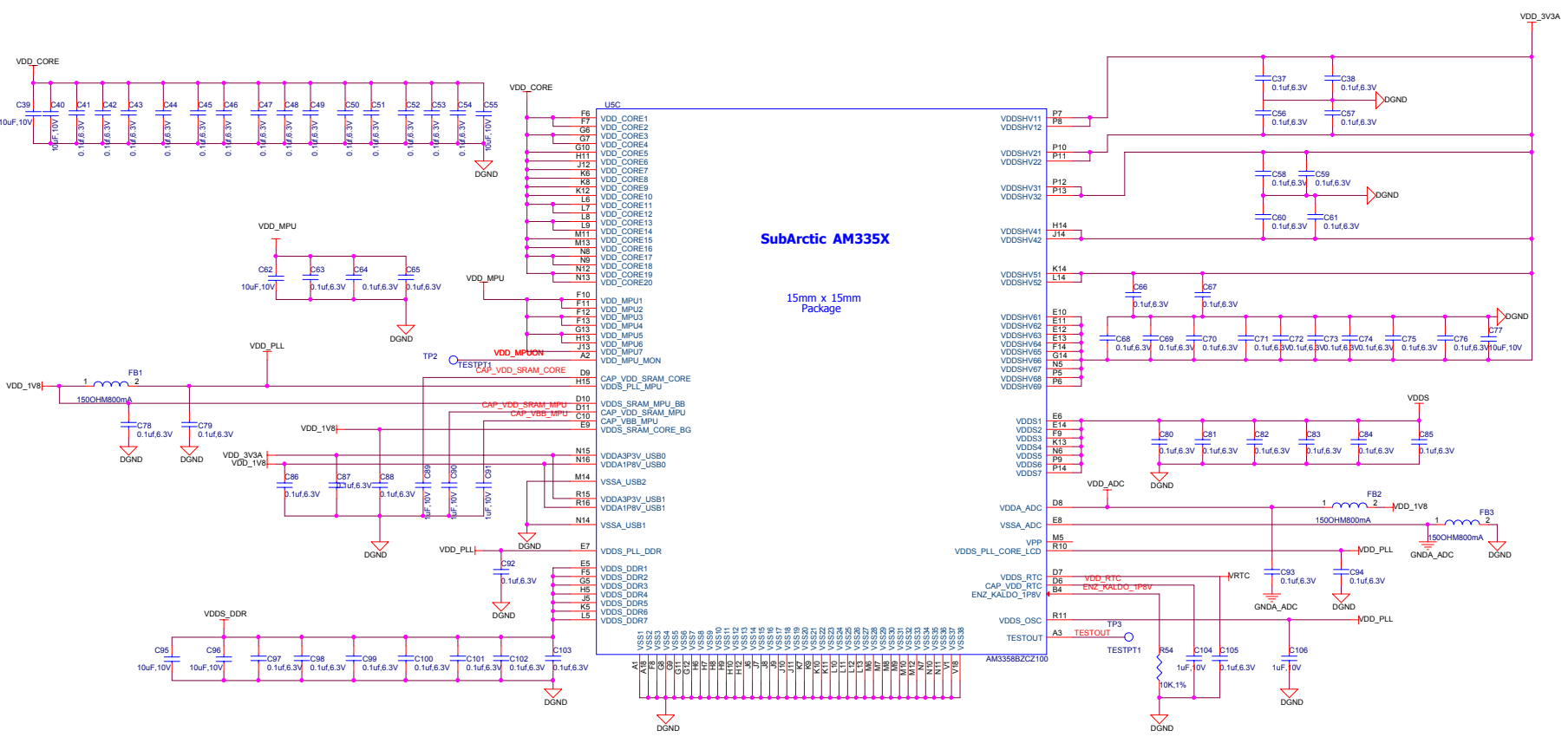

**SubArctic AM335X**  
15mm x 15mm Package

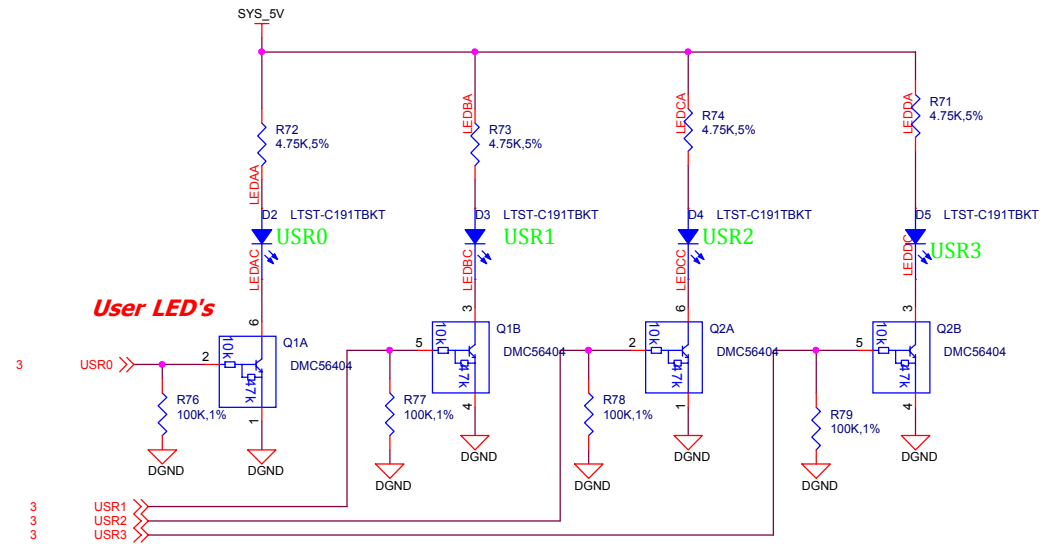
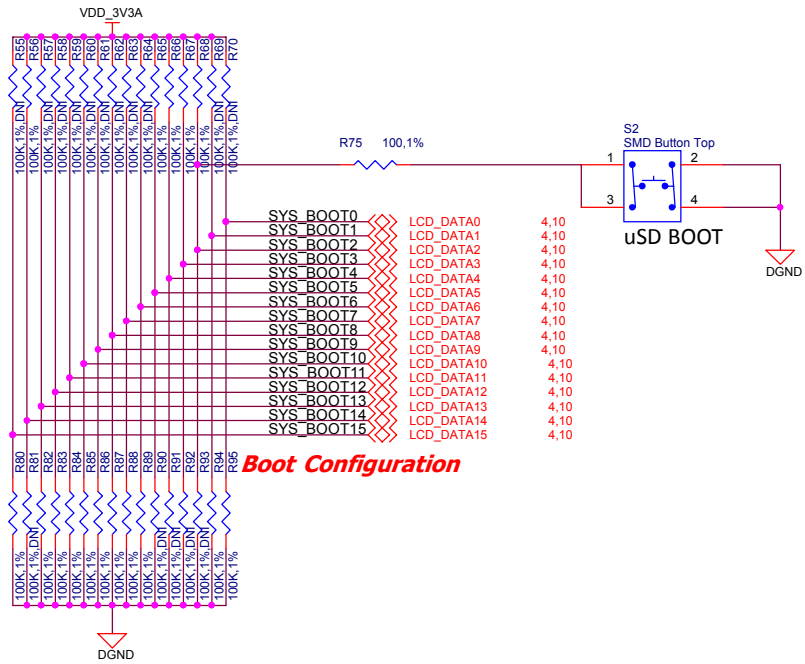

SYSBOOT[15:14]	SYSBOOT[13:12]	SYSBOOT[11:10]	SYSBOOT[9]	SYSBOOT[8]	SYSBOOT[7:6]	SYSBOOT[5]	SYSBOOT[4:0]	Boot Sequence			
00b = 19.2MHz 01b = 24MHz 10b = 25MHz 11b = 26MHz	00b (all other values reserved)	Don't care for ROM code	Don't care for ROM code	Don't care for ROM code	Don't care for ROM code	0 = CLKOUT1 disabled 1 = CLKOUT1 enabled	11100b	MMC1	MMC0	UART0	USB0[5]
00b = 19.2MHz 01b = 24MHz 10b = 25MHz 11b = 26MHz	00b (all other values reserved)	Don't care for ROM code	Don't care for ROM code	Don't care for ROM code	Don't care for ROM code	0 = CLKOUT1 disabled 1 = CLKOUT1 enabled	11000b	SPI0	MMC0	USB0[5]	UART0

**seed studio**  
Grow the Difference

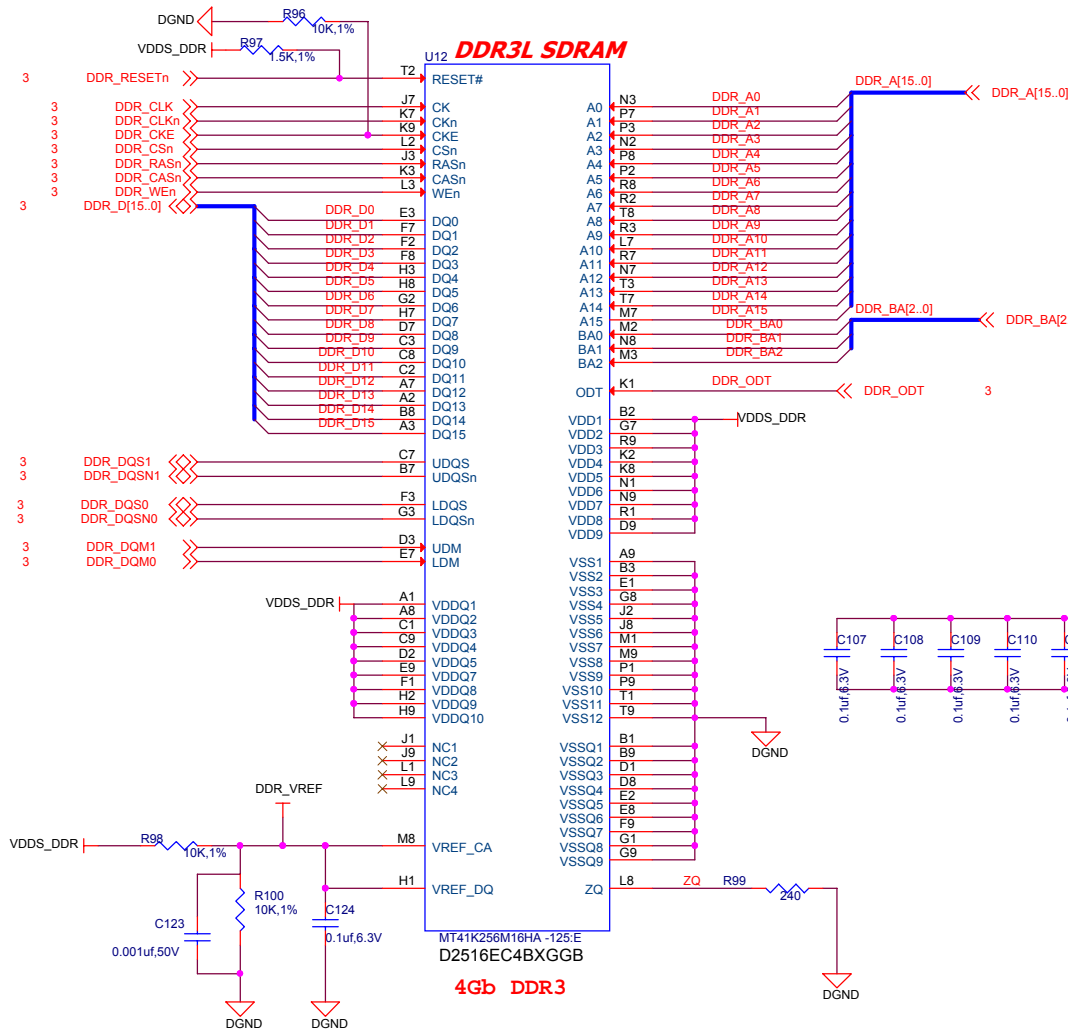

Title	BeagleBone Green LED, Configuration, and Reset	
Size	Document Number	Rev v1
Date:	Thursday, June 04, 2015	Sheet 6 of 10



Title		
BeagleBone Green DDR3 Memory		
Size	Document Number	Rev
B		v1
Date:	Thursday, June 04, 2015	Sheet 7 of 10

3.10  
3.10  
3.10  
3.10  
3.10  
3.10  
3.10  
3.10  
3.10  
3.10  
3

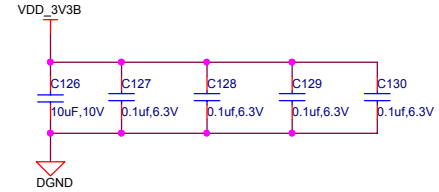
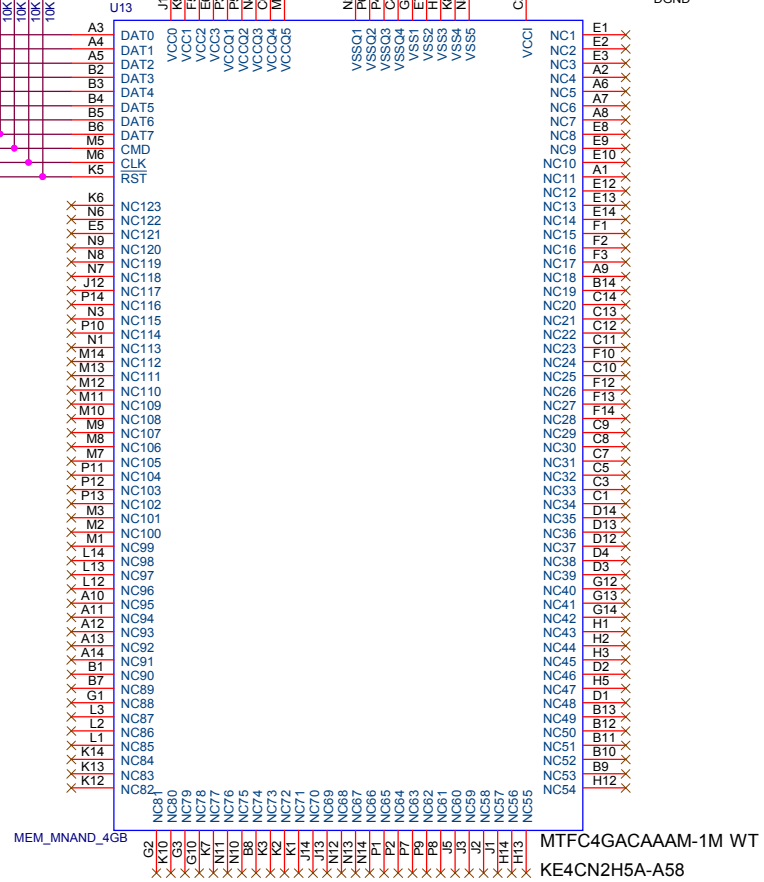
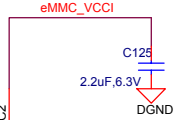
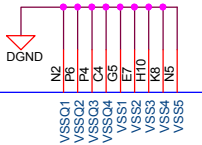
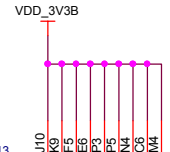
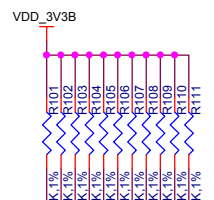
MMC1\_DAT0  
MMC1\_DAT1  
MMC1\_DAT2  
MMC1\_DAT3  
MMC1\_DAT4  
MMC1\_DAT5  
MMC1\_DAT6  
MMC1\_DAT7  
MMC1\_CMD  
MMC1\_CLK  
eMMC\_RSTn

**seed** studio  
Grow the Difference

Title		BeagleBone Green 4G eMMC
Size	Document Number	Rev
B		v1
Date:	Thursday, June 04, 2015	Sheet 8 of 10



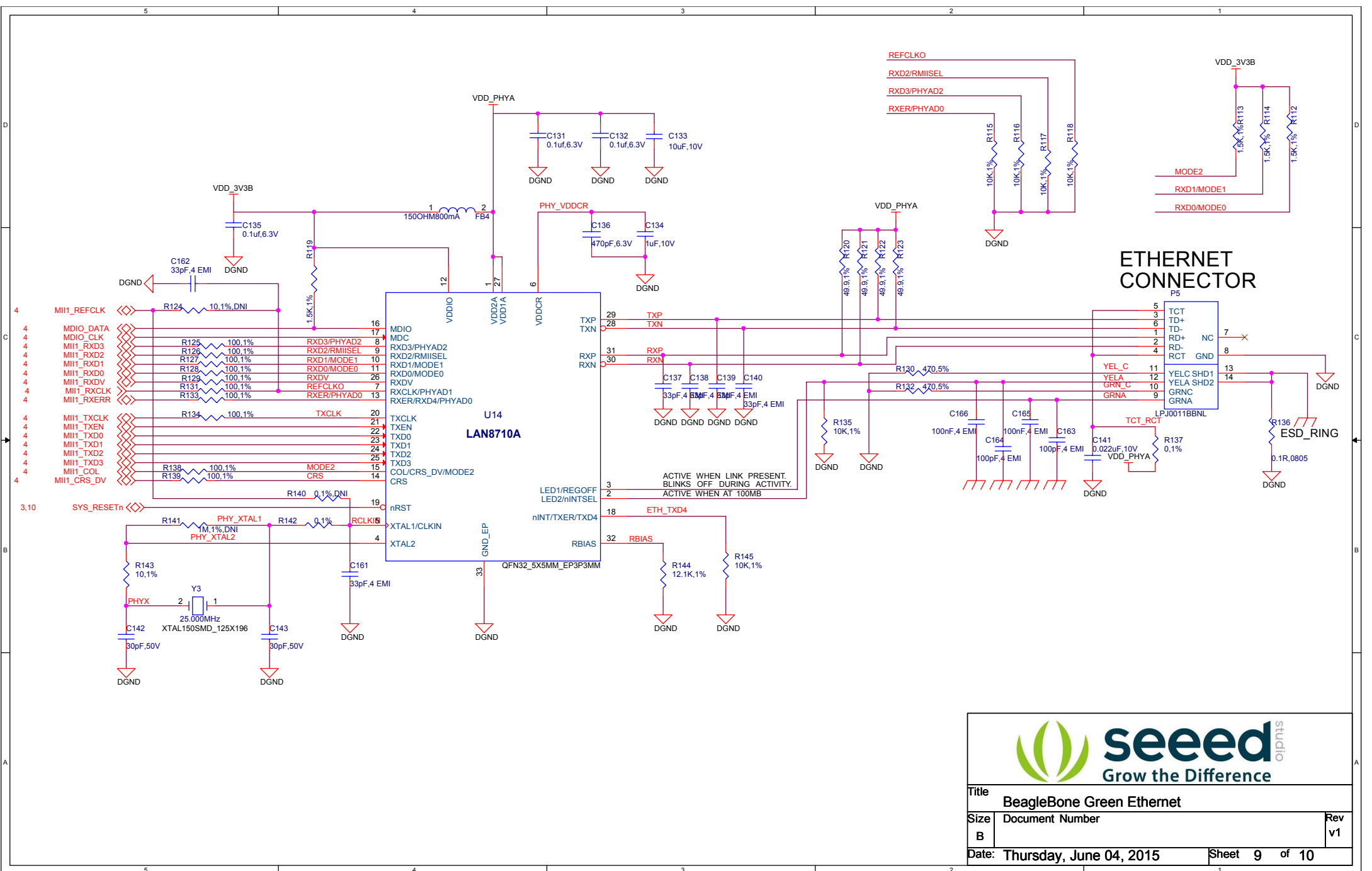

### ETHERNET CONNECTOR

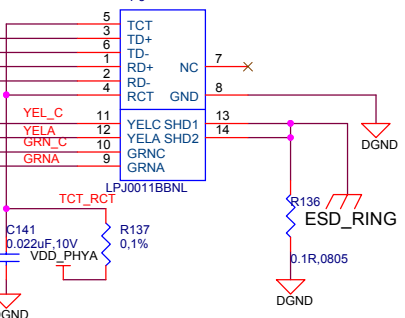

Title		BeagleBone Green Ethernet	
Size	Document Number		Rev
B			v1
Date:	Thursday, June 04, 2015	Sheet	9 of 10

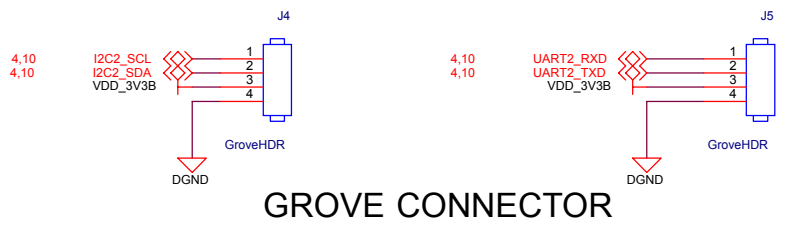
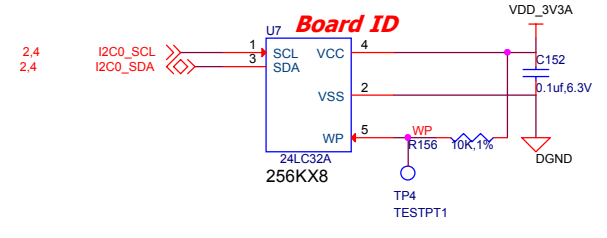
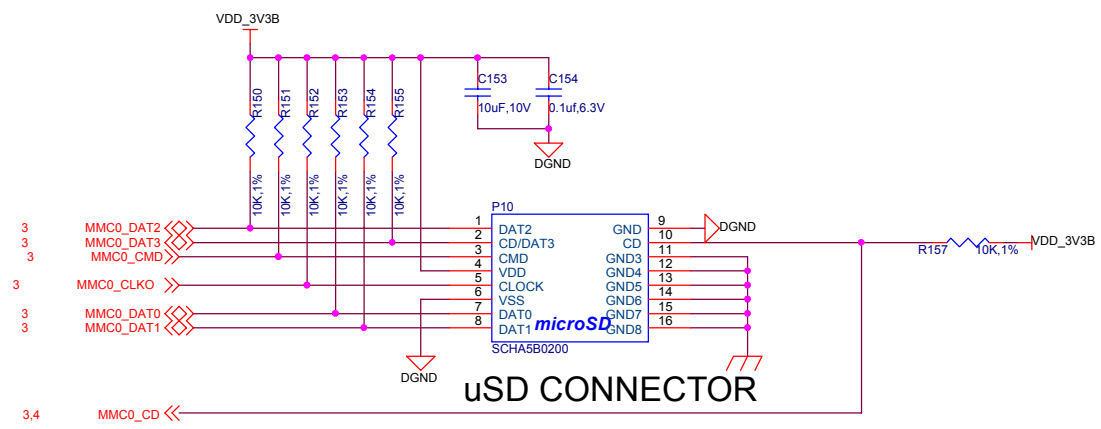
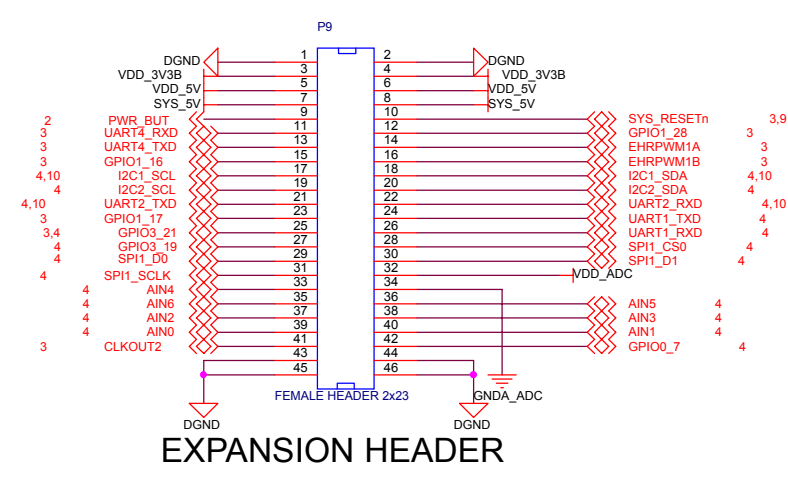
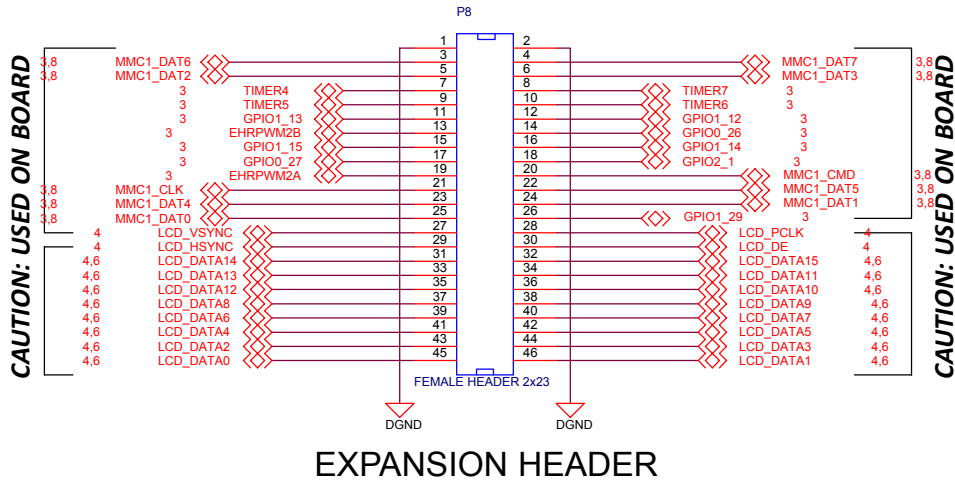

**seed studio**  
Grow the Difference

Title: BeagleBone Green Expansion Headers, uSD and EEPROM

Size: Document Number | Rev: v1

Date: Thursday, June 04, 2015 | Sheet: 10 of 10