



- 6-DIGIT PROGRAMMABLE PROJECTION
- COUNTER/FREQUENCY/TIMER/CLOCK
- UP/DW COUNTER, IRC
- DIGITAL FILTER, TARE, LINEARIZATION, SUM
- SIZE OF DIN 96 X 48 MM
- POWER SUPPLY 80...250 V AC/DC
- Option
  - Excitation • Comparators • Data output • Analog output
  - Three-color display - 20 mm • Power supply 10...30 V AC/DC

## OM 653UQC

**OMLINK**

The OM 653UQC type is a universal low-cost counter/frequencymeter/evaluation of signal from IRC sensor/stopwatch/timer.

The instrument is based on an 8-bit microcontroller, which ensures good accuracy, stability and easy operation of the instrument.

**OM 653UQC**  
UNIVERSAL COUNTER

### OPERATION

The instrument is set and controlled by five control keys located on the front panel. All programmable settings of the instrument may be performed in three adjusting modes:

**LIGHT MENU** is protected by optional number code and contains solely items necessary for instrument setting

**PROFI MENU** is protected by optional number code and contains complete instrument setting

**USER MENU** may contain arbitrary items from the programming menu (LIGHT/PROFI), which determine the right (see, change). Access w/o password.

Standard equipment is the OM Link interface, which together with operation program enables modification and filing of all instrument settings as well as perform firmware updates (with OML cable). The program is also designed for visualization and filing of measured values from more instruments .

All settings are stored in the EEPROM memory (they hold even after the instrument is switched off).

### OPTIONS

**EXCITATION** is suitable for feeding of sensors and transmitters. It is isolated, with continuously adjustable value in the range of 5...24 VDC.

**COMPARATORS** are assigned to monitor two limit values with relay output. The limits have adjustable hysteresis within the full range of the display as well as selectable delay of the switch-on in the range of 0...99,9 s. Reaching the preset limits is signalled by LED and simultaneously by the switch-on of the relevant relay.

**DATA OUTPUTS** are for their rate and accuracy suitable for transmission of the measured data for further projection or directly into the control systems. We offer an isolated RS232 and RS485 with the ASCII/MODBUS/PROFIBUS protocols.

**ANALOG OUTPUTS** will find their place in applications where further evaluating or processing of measured data is required in external devices. We offer universal analog output with the option of selection of the type of output - voltage/current. The value of analog output corresponds with the displayed data and its type and range are selectable in menu.

**TIME BACKUP** is suitable where time needs to be measured even in case of supply voltage outage (upon power supply outage the instrument does not display).

### STANDARD FUNCTIONS

#### PROGRAMMABLE PROJECTION

**Selection:** measuring mode

**Setting:** measuring mode counter/frequency/timer/ counter for IRC/clock with adjustable calibration coefficient, time base and projection

**Measuring mode:** counter/frequency/UP-DW counter/frequency/counter for IRC

**Measuring channels:** A and B, from one measuring input two independent functions may be evaluated (counter/frequency)

**Projection:** -99999...999999

#### LINEARIZATION

**Linearization:** through linear interpolation in 25 points (solely via OM Link)

#### DIGITAL FILTERS

**Exponential average:** from 2...100 measurements

**Rounding:** setting the projection step for display

**Filtration constant:** transmits input signal up to 5...1 000 Hz

#### FUNCTION

**Preset:** initial non-zero value, which is always read after resetting the instrument to zero

**Setting current value:** initial value, e.g. amount passed-through

**Tare:** resetting display upon non-zero input signal

#### EXTERNAL CONTROL

**Hold:** display/instrument blocking

**Lock:** control keys blocking

**Resetting:** counter resetting

**Start/Stop:** stopwatch/timer control

## TECHNICAL DATA

### PROJECTION

**Display:** 999999, red or green 7-segment LED, digit height 14mm, -999..9999, red/green/orange 7-segment. LED, height 20mm  
**Decimal point:** setting - in menu  
**Brightness:** setting - in menu

### INSTRUMENT ACCURACY

**TC:** 50 ppm/°C  
**Accuracy:** ±0,05% of value + 1 digit  
 ±0,01% of value ±2 ms [Stopwatch]  
 ±0,01% of value ±130 ms [RTC]  
**Overload capacity:** 10x [t < 30 ms]; 2x  
**Watch-dog:** reset after 500 ms  
**Functions:** HOLD, LOCK, Digital filters, Tare  
**Functions:** Data backup, Time backup, Preset  
**Input filters:** Filtration constant, Rounding  
**Time base:** 0,5/1/5/10 s  
**Calibration constant:** 0,00001...999999  
**Filtration constant:** 0/5/40/100/1000 Hz  
**PRESET:** 0...999999  
**DM Link:** Company communication interface for operation, setting and update of instruments  
**Calibration:** at 25°C and 40% r.h.

### COMPARATOR

**Type:** digital, setting in menu, contact switch < 50 ms  
**Limits:** -99999...999999; -999...9999  
**Hysteresis:** 0...999999; -999...9999  
**Delay:** 0...99,9 s  
**Output:** 2x Form A relays [250 VAC/30 VDC, 3 A], 2x open collector

### DATA OUTPUT

**Protocol:** ASCII, PROFIBUS  
**Data format:** 8 bit + no parity + 1 stop bit  
**Rate:** 300...230 400 Baud  
 9 600 Baud...12 Mbaud [PROFIBUS]  
**RS 232:** isolated  
**RS 485:** isolated, addressing (max. 31 instruments)  
**Ethernet:** 10/100BaseT, Security Protocols, POP3, FTP

### ANALOG OUTPUT

**Type:** isolated, programmable with 12-bit D/A converter, type and range are selectable in programming mode  
**Non-linearity:** 0,1% of range  
**TC:** 15 ppm/°C  
**Rate:** response to change of value < 1 ms  
**Ranges:** 0...2/5/10 V, ±10 V, 0...5 mA, 0/4...20 mA [komp. < 500 0/12 V]

### EXCITATION

**Adjustable:** 5...24 VDC/max. 1,2 W

### POWER SUPPLY

10...30 V AC/DC, ±10 %, max. 13,5 VA, PF≥0,4, I<sub>SP</sub>< 40 A/1 ms  
 80...250 V AC/DC, ±10 %, max. 13,5 VA, PF≥0,4, I<sub>SP</sub>< 40 A/1 ms  
**Power supply is protected by a fuse inside the instrument**

### MECHANIC PROPERTIES

**Material:** Noryl GFN2 SE1, incombustible UL 94 V-I  
**Dimensions:** 96 x 48 x 120 mm  
**Panel cutout:** 90,5 x 45 mm

### OPERATING CONDITIONS

**Connection:** connector terminal board, section < 1,5/2,5 mm<sup>2</sup>  
**Stabilization period:** within 15 minutes after switch-on  
**Working temperature:** -20°...60°C  
**Storage temperature:** -20°...85°C  
**Cover:** IP64 (front panel only)  
**El. safety:** EN 61010-1, A2  
**Dielectric strength:** 4 kVAC after 1 min between supply and input  
 4 kVAC after 1 min between supply and data/analog output  
 4 kVAC after 1 min between supply and relay output  
 2,5 kVAC after 1 min between input and data/analog output  
**Insulation resistance:** for pollution degree II, measuring cat. III, power supply > 670 V [PI], 300 V [DI]  
 Input, output, Exc. > 300 V [PI], 150 V [DI]  
**EMC:** EN 61326-1

PI - Primary insulation, DI - Double insulation

## MEASURING RANGES

OM 653 is a multifunction instrument available in following types

**UQC:** 0...30 V/0...300 V, comparison levels are adjustable in the menu  
 input frequency 0,1 Hz...50 kHz [20 kHz for QVADR and UP/DW]

### Measuring modes

**SINGLE** Counter/Frequencymeter  
**QVADR** Counter/Frequencymeter for IRC sensors  
**UP/DW** UP/DW Counter/Frequencymeter  
 - used in inputs A, B [direction] and can display count/frequency  
**UP - DW** UP - DW Counter/Frequencymeter  
 - used in inputs A [UP], B [DW] and can display count/frequency  
**TIME** Stopwatch  
**RTC** Timer

## CONNECTION

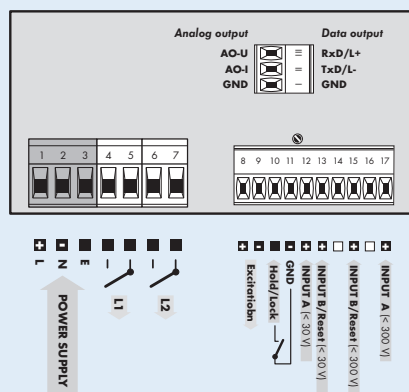

## ORDER CODE

### OM 653UQC

		0	1	2	3	4	5	6	7	8	9	00
<b>Power supply</b>	10...30 V AC/DC	0										
	80...250 V AC/DC	1										
<b>Comparators</b>	no	0										
	1x relay (Form A)	1										
	2x relays (Form A)	2										
	1x open collector	3										
	2x open collector	4										
<b>Output</b>	none		0									
	Analog output		2									
	RS 232		3									
	RS 485		4									
	PROFIBUS		6									
	10/100BaseT Ethernet (not possible with analog output)*		7									
	Excitation	no		0								
yes			1									
<b>Time backup</b>	no				0							
	yes				1							
<b>Display color</b>	red (14 mm)					1						
	green (14 mm)					2						
	red/green (20 mm)					3						
<b>Other</b>	customer version, do not fill in										00	

Default execution is shown in bold

\* Launch for sale has not been set