

- 6-DIGIT PROGRAMMABLE PROJECTION
- MULTIFUNCTION INPUT (DC, PM, RTD, T/C, DU)
- DIGITAL FILTERS, LINEARIZATION
- SIZE OF DIN 72 X 24 MM
- POWER SUPPLY 10...30 V AC/DC
  
- Option  
Comparators

## OMM 350



The OMM 350 model series are small 6-digit panel programmable instruments designed for maximum usefulness and user comfort while maintaining its fair price. There are two versions available: UNI and DC.

The OMM 350UNI type is a multifunction instrument with the option of configuration for 8 different input options, easily configurable in the instrument menu. Version OMM 350DC is suitable for measurement of larger ranges of DC voltage and current.

The instrument is based on an 8-bit microcontroller with A/D converter, which ensures good accuracy, stability and easy operation of the instrument.

**OMM 350DC**  
DC VOLTMETER AND AMMETER

**OMM 350UNI**  
DC VOLTMETER AND AMMETER  
PROCESS MONITOR  
OHMMETER  
THERMOMETER FOR Pt/Cu/Ni/Termocouples  
DISPLAY UNIT FOR LINEAR POTENTIOMETERS

### OPERATION

The instrument is set and controlled by four control keys located on the front panel. All programmable settings of the instrument may be performed in three adjusting modes:

**LIGHT MENU** is protected by optional number code and contains solely items necessary for instrument setting

**PROFI MENU** is protected by optional number code and contains complete instrument setting

**USER MENU** may contain arbitrary items from the programming menu (LIGHT/PROFI), which determine the right (see, change). Access w/o password.

Standard equipment is the OM Link interface, which together with operation program enables modification and filing of all instrument settings as well as perform firmware updates (with OML cable).

All settings are stored in the EEPROM memory (they hold even after the instrument is switched off).

### OPTIONS

**COMPARATORS** are assigned to monitor two limit values with relay output. The limits have adjustable hysteresis within the full range of the display as well as selectable delay of the switch-on in the range of 0...99,9 s. Reaching the preset limits is signalled by LED and simultaneously by the switch-on of the relevant relay.

### STANDARD FUNCTIONS

#### PROGRAMMABLE PROJECTION

**Setting:** manual, optional display projection may be set in the menu for both limit values of input signal, e.g. input 0...19,99 V  $\Rightarrow$  0...150,0

**Projection:** -99999...999999

#### COMPENSATION

**of conduct (RTD, OHM):** automatic (3- and 4-wire) or manual in menu (2-wire)

**of conduct in probe (RTD):** internal connection (conduct resistance in measuring head)

**of CJC (T/C):** manual or automatic, in menu it is possible to perform selection of the type of thermocouple and compensation of cold junctions, which is adjustable or automatic (temperature at the input brackets)

#### LINEARIZATION

**Linearization:** through linear interpolation in 25 points (solely via OM Link)

#### DIGITAL FILTERS

**Exponential average:** from 2...100 measurements

**Rounding:** setting the projection step for display

#### EXTERNAL CONTROL

**Hold:** display/instrument blocking

**Lock:** control keys blocking

## TECHNICAL DATA

### PROJECTION

**Display:** -99999...999999, red or green 7-segment LED, digit height 9,1mm  
**Decimal point:** setting - in menu  
**Brightness:** setting - in menu

### INSTRUMENT ACCURACY

**TK:** 50 ppm/°C  
**Accuracy:** ±0,2% of range + 1 digit (for projection ±1999) ±0,3% of range + 1 digit **T/C**  
**Accuracy of cold junction measurement:** ±1,5°C  
**Rate:** 0,5...10 meas./s  
**Overload capacity:** 10x [t < 30 ms] - not for 200 V and 5A; 2x  
**Resolution:** 0,1°C [RTD], 1°C [T/C]  
**Watch-dog:** reset after 500 ms  
**Functions:** HOLD, LOCK, Digital filters  
**DM Link:** Company communication interface for operation, setting and update of instruments  
**Calibration:** at 25°C and 40% r.h..

### COMPARATORS

**Type:** digital, setting in menu, contact switch-on < 50 ms  
**Limit:** -99999...999999  
**Hysteresis:** 999999  
**Delay:** 0...99,9 s  
**Output:** 2x bistable relays [48 VAC/30 VDC, 3 A]

### POWER SUPPLY

10...30 VDC/24 VAC, max. 4 VA, PF ≥ 0,4, I<sub>SP</sub> < 45 A/1 ms, isolated

### MECHANIC PROPERTIES

**Material:** Noryl GFN2 SE1, incombustible UL 94 V-1  
**Dimensions:** 72 x 24 x 106 mm  
**Panel cutout:** 68 x 22,5 mm

### OPERATING CONDITIONS

**Connection:** connector terminal board, section < 1,5/2,5 mm<sup>2</sup>  
**Stabilization period:** within 15 minutes after switch-on  
**Working temperature:** -20°...60°C  
**Storage temperature:** -20°...85°C  
**Cover:** IP42 (front panel only)  
**El. safety:** EN 61010-1, A2  
**Dielectric strength:** 2,5 kVAC after 1 min between supply and input  
 2,5 kVAC after 1 min between supply and relay output  
**Insulation resistance:** for pollution degree II, measuring cat. III.  
 Power supply, input > 300 V [PI], 250 V [DI]  
**EMC:** EN 61326-1  
**Seismic capacity:** IEC 980:1993, par. 6

PI - Primary insulation, DI - Double insulation

## MEASURING RANGES

OMM 350 is a multifunction instrument available in following types and ranges

### Type UNI

**DC:** ±20/±60/±1 000 mV  
**PM:** 0...20 mA/4...20 mA/0...2 V/ 0...5 V /0...10 V  
**OHM:** 0...300 Ω/0...1,5 kΩ/0...3 kΩ/0...30 kΩ  
**RTD:** Pt 50/100/Pt 500/Pt 1 000  
**Cu:** Cu 50/Cu 100  
**Ni:** Ni 1 000/10 000  
**T/C:** J/K/T/E/B/S/R/N/L  
**DU:** Linear potentiometer (min. 500 Ω)

### Type DC

**DC - Hi:** ±1 A/±5 A/±20 V/±40 V/±100 V/±200 V

### CONNECTING INDIVIDUAL INPUTS

	INPUT 1	INPUT 2	INPUT 3	INPUT 4	INPUT 5
<b>DC</b>	0...1 V		0...60 mV	0...20 mV	
<b>PM</b>	0...5/10 V			0...2 V	0...20 mA, 4...20 mA
<b>T/C</b>			J/K/E/N/L	B/S/R/T	
<b>DC/Hi</b>	±100/±200 V	±20/40 V			±1/±5 A

### ORDER CODE SPECIFICATION

UNI	
<b>A</b>	Pt 100/0...300 Ω
<b>B</b>	Pt 500/0...1 500 Ω
<b>C</b>	Pt 1 000/Ni 1 000/0...3 kΩ
<b>D</b>	Ni 10 000/0...30 kΩ
<b>Z</b>	on request

## CONNECTION

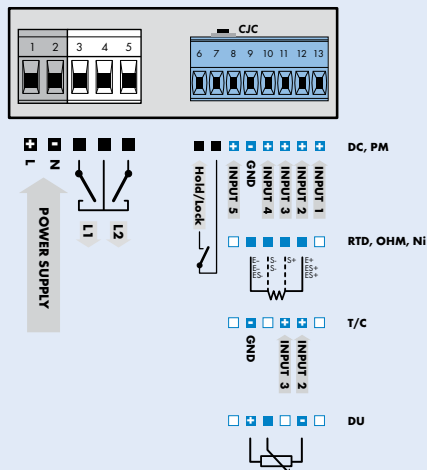

## ORDER CODE

### OMM 350

□ □ □ - 0 □ □ □ - □

#### Type

Order code shall not include blank spaces!

	U	N	I	.	.	.	.	.	.
<b>Power supply</b>				0					
<b>Measuring range</b> , see table „Order code specification“				?					
<b>Comparators</b>				no					
				1x relay (Form A)					0
				2x relays (Form A)					1
				1x open collector					2
				2x open collector					3
									4
<b>Display color</b>				red					1
				green					2
<b>Other</b>				customer version, do not fill in					00

\*In the „UNI“ type the measuring range is selected under the order code solely for RTD, Ni, OHM. For other types this item has no significance with default setting „A“ !

Default execution is shown in bold